

# **Contribution to Quality and Process Optimisation in Continuous Casting Using Mathematical Modelling**

Von der Fakultät für Maschinenbau, Verfahrens- und Energietechnik

**der Technischen Universität Bergakademie Freiberg**

eingereichte

## **DISSERTATION**

zur Erlangung des akademischen Grades

Doktor-Ingenieur (Dr.-Ing.)

vorgelegt von M.Sc. Eng. **Salah Bouhouche**

geboren am 26. Oktober 1960 in Collo/Skikda (Algerien)

Gutachter: Prof. Dr.-Ing. habil. J. Bast

Prof. Dr.-Ing. habil. Dr. h. c. D. Janke

Dr.-Ing. habil. H.-J. Hartmann

Freiberg, den 18. Dezember 2002

# CONTENT

<b>1 INTRODUCTION</b>	<b>11</b>
1.1 Description of main steelmaking processes	12
1.2 Problem statement and objectives	14
1.3 Process parameter analysis and control	17
<b>2 MATHEMATICAL MODELLING</b>	<b>19</b>
2.1. Conventional modelling	19
2.1.1 <i>Identification models</i>	21
2.1.2 <i>Process control</i>	23
2.2 Neural network modelling	23
2.2.1 <i>Neural network identification and modelling</i>	24
2.2.1.1 Problem formulation and back-propagation learning	24
2.2.1.2 Learning algorithm	26
2.2.2 <i>Neural process control</i>	27
2.2.3 <i>Neural process optimisation and monitoring</i>	29
<b>3 MODELLING OF LADLE METALLURGICAL TREATMENT PROCESSES</b>	<b>30</b>
3.1 Introduction	30
3.2 Process description	32
3.3 Process modelling and identification	34
3.3.1 <i>Linear model</i>	34
3.3.2 <i>Neural network model</i>	35
3.4 Application	41
3.5 Results and analysis	44
<b>4 CONTROLLED SOLIDIFICATION IN CONTINUOUS CASTING MOULDS</b>	<b>46</b>
4.1 Control and monitoring of solidification in the mould	47
4.2 Analysis of breakout phenomena	48

<i>4.2.1 Breakout propagation process</i>	48
<i>4.2.2 Breakout effect in the mould temperature field</i>	49
4.3 Breakout prediction and detection	50
<i>4.3.1 Mould instrumentation and measurement of thermal profiles</i>	51
<i>4.3.2 Conventional methods</i>	53
<i>4.3.3 Advanced methods using neural network modelling</i>	55
4.3.3.1 Upper processing unit	55
4.3.3.1.1 Time series model	55
4.3.3.1.2 Spatial model	59
4.3.3.2 Lower processing unit	60
4.3.3.2.1 Time series model	60
4.3.3.2.2 Spatial model	62
<i>4.3.4 Application</i>	63
4.3.4.1 Application to real breakout prediction	64
4.3.4.2 Application to false breakout prediction	72
<i>4.3.5 Results and analysis</i>	77
<b>5 CONTROL OF HEAT TRANSFER IN SECONDARY COOLING</b>	<b>79</b>
5.1 Introduction	79
5.2 Simplified heat transfer control model	80
5.3 Measurement and experimental data analysis	83
5.4 Conventional control	87
<i>5.4.1 Feed forward control</i>	87
<i>5.4.2 Proportional, integral and derivative digital control</i>	89
5.5 Neural network control	94
<i>5.5.1 Overall structure of the neural networks control</i>	94
<i>5.5.2 Control using neural networks</i>	95
5.6 Results of simulation	98

<b>6 FAULT AND QUALITY PREDICTION BY DATABASE MODELLING</b>	<b>99</b>
6.1 Breakout alarm and quality monitoring in continuous casting	99
6.1.1 <i>Position of the problem</i>	99
6.1.2 <i>Alarm, breakout and quality monitoring</i>	100
6.1.2.1 Classification	101
6.1.2.2 Modelling	102
6.2 Process monitoring and fault detection of casting speed	102
6.2.1 <i>Position of the problem</i>	104
6.2.2 <i>Process analysis and diagnosis</i>	105
6.2.3 <i>Fault detection and modelling</i>	107
6.2.4 <i>Application</i>	109
6.2.5 <i>Results</i>	109
<b>7 CONCLUSION AND OUTLOOK</b>	<b>113-115</b>
<b>8 REFERENCES</b>	<b>116-125</b>

**To my mother “Cherifa”**

**To my wife ”Mounira”**

**To my children “Abir and Mohammed-Nadjib”**

## ACKNOWLEDGEMENT

The author would like to thank Prof. Dr.-Ing. habil. J. Bast of the Department Metallurgical, Foundry and Forming Machines (HGUM) at the TU Bergakademie Freiberg for his guidance and helpful advice. I am indebted to him for his direct and careful supervision of this thesis from its development to completion and for his constant encouragement as well as his financial and logistic support at the various stages of this work.

I would like to give special thanks to Prof. Dr.-Ing. habil.Dr.h.c. D. Janke of the Institute of Iron and Steel Technology and Prof. Dr.-Ing.habil. P. Löber of the Institute of Automation at the TU Bergakademie Freiberg for reading the initial manuscript and critical comments. Special thanks go to Dr.-Ing.habil. H.-J. Hartmann of the Research and Quality Centre (Forschungs- und Qualitäts Zentrum, "FQZ" Brandenburg) for his critical evaluation of this work.

I am very grateful to the staff and colleagues Dr. M. Lahreche and Dipl.-Ing. H. Meradi of the Steel Department at the SIDER-Applied Research Unit (DRA) Algeria for their help and encouragement. Special thanks go to Dr. M. Lahreche for his kindness and discussion on the field of the metallurgical and technical aspects.

My thanks go to Dr.-Ing.habil. H.-J. Hartmann, Dipl.-Ing. J.Gellert and Dipl.-Ing. J.Robert of the FQZ for their assistance for temperature measurement in secondary cooling and breakout data acquisition from process computers.

I am very grateful Dr.-Ing. D. Herrwig, Prof. Dr.-Ing. habil. R. Hartmann and Prof.Dr.-Ing.habil. H.-P. Lüpfer for their lectures in the field of Mechanical Engineering.

My thanks go to Dipl.-Math. D. Renker, Dipl.-Ing. M. Aitsurade, Dipl.-Chem. (FH). A. Müller and Dipl.-Ing. M. Ruffert of the Department Metallurgical, Foundry and Forming Machines (HGUM), TU Bergakademie Freiberg for their help.

I am very grateful to the Dr.-Ing. M.S. Boucherit of the Algerian Institute of Technology for his lectures in the field of Control Engineering.

I am grateful to Dr A.Edet of the University of Calabar, Nigeria for reading and correcting the manuscript.

The data for my work were kindly provided by Dipl.-Ing. A. Kahit and Dipl.-Ing. R. Benslama from SIDER Steelworks Algeria. To all I acknowledge their kindness.

I wish to express my sincere thanks to all workers in continuous casting process in Algeria (SIDER ) and in Germany (EKO STAHL and FQZ) for their help of providing data during my study.

I am deeply grateful to the Deutscher Akademischer Austauschdienst (DAAD) and the Deutsche Gesellschaft für Technische Zusammenarbeit (GTZ) for financing my doctoral work.

The main work of this thesis has been carried out between 1996 and 2000 in the field of Steel Research & Development as a result of technical cooperation between Algeria (SIDER, Applied Research Unit) and Germany (TU Bergakademie Freiberg) and financed by GTZ.

## Information about the Author

Bouhouche Salah was born on the 26<sup>th</sup> October 1960 in Collo/ Skikda, in Algeria. Between 1977 and 1980 he attended the secondary school in Skikda/ Algeria. From 1980 to 1985 he obtained his diploma in Engineering (Automation) from the Algerian Institute of Hydrocarbons and Chemistry, (Institut National des Hydrocarbures et de la Chimie) –Boumerdes, Algeria. During the period (1986-1988) he did his military service in Algerian forces. From 1988-1991, he worked as a research engineer at the applied research unit in the Algerian steel industry, (DRA-SIDER Group.Spa). In the year 1995 he obtained a Master degree (Magister thesis) in Control Engineering from the Algerian Institute of Technology (Ecole Nationale Polytechnique). From 1996 he worked in the field of the mathematical modelling in steel industry and as a candidate to PhD thesis.

He speaks Arabic (native language), French, English and German. His hobbies are footing and reading.



The address of the author is:

PO BOX 196; 23300, Annaba, Algeria

E-mail:bouhouche@yahoo.fr

Tel(Private):00 213 38 87 68 98



## SYMBOLS

AND	:Logic function AND
$A(q^{-1})$	:Output polynomial coefficients of $q^{-1}$
$\alpha$	:Momentum (see neural networks software)
$B(q^{-1})$	:Input polynomial coefficients of $q^{-1}$
BP	:Back-Propagation
$\beta_i, \lambda_i$	:Pole coefficients for reference model
$C(q^{-1})$	:Disturbance polynomial coefficients of $q^{-1}$
$C_{pi}$	:Slab specific heat [Cal/ kg °C]
$C_{pe}$	:Water specific heat [Cal/ kg °C]
d	:Desired values
d(t)	:Desired values (dynamic)
Dynschell	:Mathematical model for the strand temperature calculation
$\Delta q^E$	:Variations of mass or energy quantity
$\Delta T^{U-L}$	:Mould upper and lower temperature difference [°C]
$\Delta t$	:Sampling time [min]
$\Delta W$	:NN weight variation
EAF	:Electrical arc furnace
$E_p$	:Learning quadratic index
$e_i$	:Modelling error
$e_u(t)$	:Tracking error
IR	:Infra- Red
I(t)	:Motor current
J	:Criterion
$K_{Ri}$	:Proportional action
L,h,l <sub>i</sub>	:Strand geometrical dimensions [m]
$\lambda(t)$	:Forgetting factor
NN	:Neural Network
$\eta$	:Learning rate
MTM	:Mould Thermal Monitoring
$m_i$	:Mass of zone(i) [kg]
OR	:Logic function OR

PID	:Proportional, Integral and Derivative controller
$P(t)$	:Gain matrix
Q	:Quality index
$Q^{\text{input}}$	:Input quantity (mass or energy)
$Q^{\text{output}}$	:Output quantity (mass or energy)
$q^E$	:Quantity dynamics (mass or energy)
$q^{-1}$	:Delay operator
$q_i(t)$	:Water flow rate at the zone (i) [kg/min or l/min]
$q_0$	:Initial water flow rate [kg/min or l/min]
$q_m(t)$	:Flow heat transfer [Cal/min]
$r_i(t)$	:Set point of reference model at the zone (i)
$\mathcal{R}^{N \times 1}$	:Real space (dimension $N \times 1$ )
$\rho$	:Density [ $\text{kg/m}^3$ ]
SSE	:Sum of Square Errors
SPC	:Statistical Process Control
$T_e$	:Water temperature [ $^{\circ}\text{C}$ ]
$T_i(t)$	:Surface temperature at the zone (i) [ $^{\circ}\text{C}$ ]
$T_{g_i}(t)$	:Target temperature at the zone (i) [ $^{\circ}\text{C}$ ]
$T_0(t)$	:Casting temperature [ $^{\circ}\text{C}$ ]
$T_{Ni}$	:Integral action
$T_{Vi}$	:Derivative action
$T^U$	:Mould upper temperature [ $^{\circ}\text{C}$ ]
$T^L$	:Mould lower temperature [ $^{\circ}\text{C}$ ]
$\theta$	:Model parameters vector
$u(t)$	:Process input
$u_p(t)$	:Predicted process input
$v(t)$	:Casting speed [m/min]
$v_c(t)$	:Set point of casting speed [m/min]
VAI	:Voest Alpine Industrial Compagny
$W_{ij}^{\text{old}}$	:NN old weight
$W_{ij}^{\text{new}}$	:NN new weight
$w(t)$	:Random noise
X	:Model input vector
$y(t), y_p(t)$	:Real and predicted process output

# 1 INTRODUCTION

Steel industries are characterized by complex phenomena particularly where there are considerable phase changes, such as the liquid–solid transformation. During this process, complex reactions which depend on the raw materials and production parameters take place. These reactions define the final quality of ingot and slabs. Actually, much work has been carried out to achieve production free defects with minimal production costs [1-3]. To realise this, a quality insurance system based on the advanced modelling was developed and applied in different steel industries [4-8]. The optimisation of a big system such as a steel plant is based on dividing the global system into different subsystems. This thesis is focused on the process optimisation and the development of process control aspects of the main iron and steel processes, particularly those that have an economical impact. It presents the development and validation of models using raw industrial data acquired from the EKO STAHL steel industry in Germany and the SIDER Group SPA in Algeria with special attention to the applied aspect. This thesis can be used as a basic work in introduction of the artificial intelligence in Algerian steel industry. It assumes a good comprehension of the new technology that will be proposed by the international engineering company at the moment of commissioning operations of steel industry modernisation.

Many mathematical models have been developed and applied worldwide in steel industry. These models use different approaches such as analytical modelling, statistical modelling and artificial intelligence modelling. This thesis is a contribution towards the application of the neural networks (NN) modelling in the steel industry. The theme of this subject is based on the introduction of the NN as a tool for the technological improvement of the process and quality. The method of investigation is based on:

- A good comprehension and analysis of the NN technology particularly for the on-line application
- Data acquisition from different steel processes in Algeria and Germany. Particular importance is given to the breakout problem, which is the main theme of this thesis
- Modelling and simulation using NN as a new tool
- Comparison of different results obtained by the NN modelling and the practice

NN modelling is an approach that is recommended for processes that feature non-linearity and noise and coupling between different inputs and outputs. Using this we can model the

analytical and logical law together. This is very complex to achieve using other modelling approaches such as statistical or physical methods.

In practice, generally a complete package of models called hybrid models is used. This involves a combination of many approaches for each situation. In this thesis the application of NN modelling to the breakout prediction is relatively new. This model is the basis for a software development equivalent to the ones developed by different companies in Asia and Europe such as Nippon Steel. More details will be given in chapter 4. The introduction of the computerised process monitoring and fault detection is a new approach for SIDER Group, Algeria. This approach allows to detect rapidly the source of defects which are monitored in real-time. The implementation of this approach is of great importance for the maintenance service that uses this as a tool of investigation.

## 1.1 Description of main steelmaking processes

The objective of the steel work is to obtain a semi final product free from defects with minimal production costs. The final quality depends on the process parameters during the production [6-11]. A general scheme of the process of steel work is given in **Fig. 1.1**. First the raw materials are transformed into liquid steel at a specified chemical composition and temperature in the Oxygen Converter or in the Electrical Arc Furnace (EAF). Then the liquid steel is poured into a ladle and transferred to the refining unit. In this unit the chemical composition and temperature are adjusted using additions (FeMn, FeSi, coke etc...) and additional heating and stirring. During this process the raw materials which are relatively expensive require reduction in terms of the cast cost [12], this aspect is the main theme of chapter 3. After refining the steel in the ladle is transferred to the continuous casting process, distributed in the tundish and cooled in the mould [12-14]. This process is characterised by phase changes such as the liquid–solid transformation. In practice, the main problem in the mould is breakout and its consequence such as the process reliability and the production shutdown induced by metal sticking in the copper mould. A breakout prediction and detection system will be presented in chapter 4. The sticking is increased as a result of the temperature variations in the tundish (**Fig. 1.2**) and the casting speed which is adjusted based on the prevailing condition such as the thermal losses in the tundish [9, 15, 16]. These variations affect the thermal profile during the secondary cooling [9, 16, 17]. This process defines the final solidification and the cooling water flow rate which is adjusted according to the process events. The secondary thermal profile control will be considered in chapter 5.

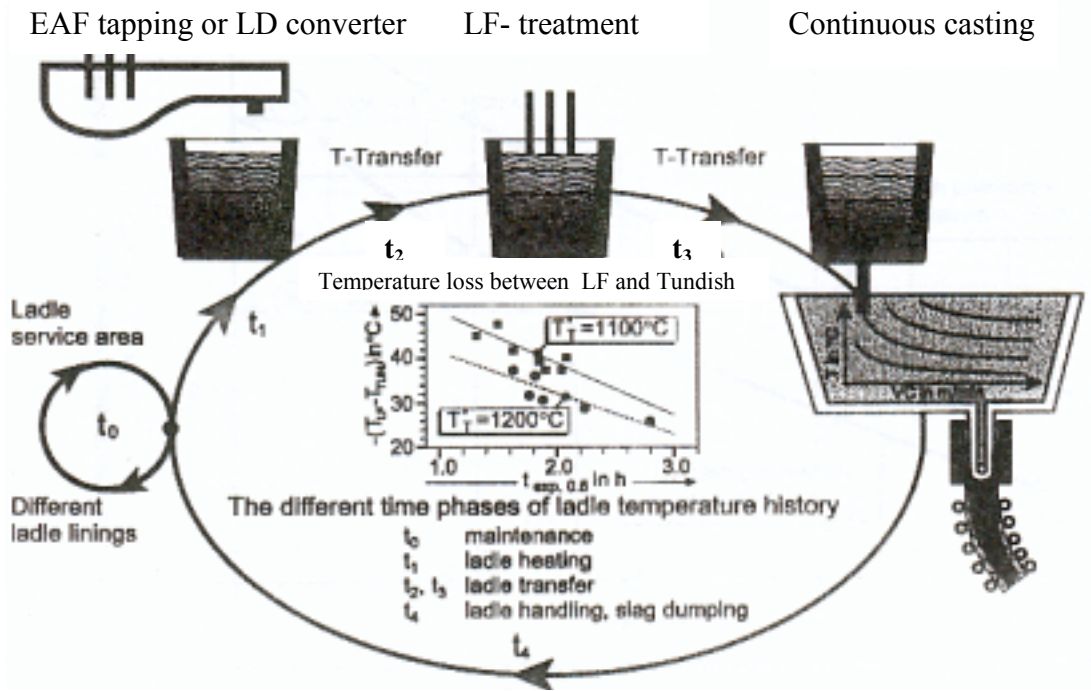


Fig. 1.1: Process description [42]

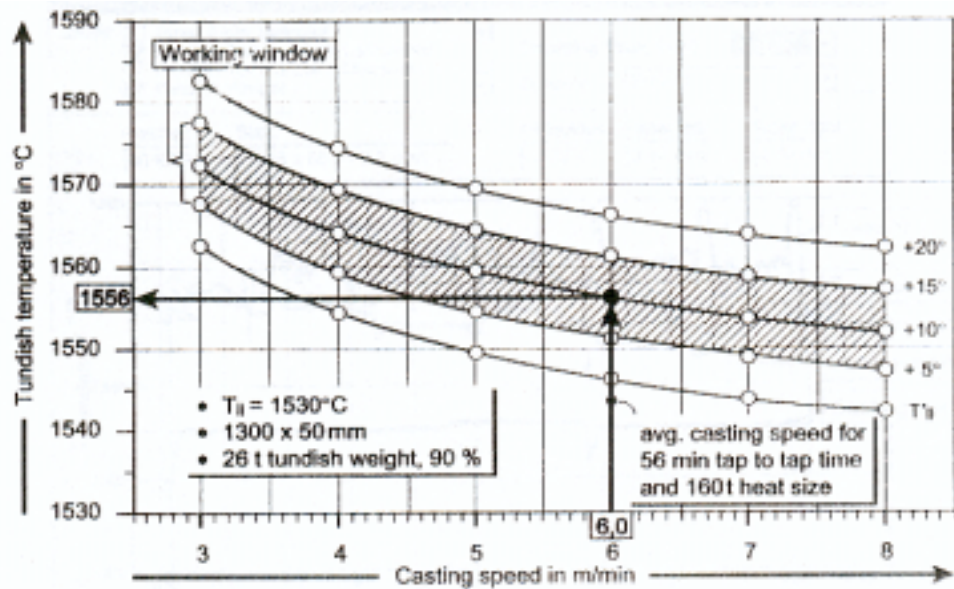


Fig. 1.2: Example of operating point [42]

The monitoring of defects in slab and ingot due to variations of process parameters is an important tool in reducing the management cost and a guarantee of the product quality [18, 19, 20]. Chapter 6 presents an application of Neural Network (NN) to predict fault detection on the power control equipment of casting speed. This problem has led to many shutdowns in order to find out the cause of the defects. The problem was solved using real-time data for monitoring and process diagnosis methods. An alarm model has been developed and implemented to predict the similar fault.

## 1.2 Problem statement and objectives

The objective of this study was to investigate the possibilities to improve the practical operating conditions in steel works using mathematical models. As defined in section 1.1, steelmaking is a complex process and it is necessary to develop some tools to optimise the process with respect to chemical composition and temperature in the refining unit, controlled solidification in the mould, secondary cooling and final quality monitoring and defect detection. Many mathematical models have been developed in the field of steelmaking. These models are based generally on the theoretical aspects and calibrated using experimental data [1, 2, 9, 14, 21-23]. Thus modelling approach is generally oriented in the field of the design and off-line simulation. From the on-line and real-time implementation point of view, this modelling approach is considered to be long. Sometimes for achieving this, it is necessary to synchronise the computer and units to reduce the computing time [24-25]. Another type of the modelling today expended in the steel industry is based on neural networks [26-45].

Most models for processing steel in the steel industry are to predict the process output parameters such as tapping temperature and chemical composition as a function of other parameters. Unfortunately the “conventional” approach, based on energy and mass balances by solving the physical and chemical equations, is very difficult, mainly because it does not consider some parameters (raw materials characteristics etc.), and the non-linear interactions between inputs and outputs. The use of neural networks for modelling can solve this problem [46-50]. First, only the phenomena at the end of the process were modelled. The dynamic follow up of the process is performed by a series of interconnected multi-layer perceptions, which are “activated” at predefined moments during the process elaboration. This work seeks to develop an approach to optimise different processes using mathematical modelling based particularly on a new modelling strategy such as neural networks and its applications to the modelling and optimisation using the appropriate data base [50-64]. In the ladle treatment

process, it considers the modelling and the optimisation of additions because the inputs are generally costly. This process permits to obtain the target chemical composition and temperature at minimal cost. The monitoring of the first solidification in the mould is achieved by the development of new breakout detection and prediction system and the breakout problem is modelled using neural networks [37, 42, 65-68]. This approach based on the use of a real breakout database from EKO STAHL reduces the false alarm number comparatively to the conventional system [37, 42, 68]. An optimal modelling and detection of this phenomenon reduces the shutdown time and the cost of maintaining the equipment. A neural closed loop control model is considered to achieve a stable surface temperature of the secondary cooling profile according to the casting events such as variations of casting speed, tundish temperature and its influence on heat transfer and slab quality particularly for sensitive steel grades [1, 9, 15-16, 18, 24, 42, 69]. Prediction and monitoring of the product quality has an important influence on the global production cost. A soft sensor using the steel work database was developed [42, 70-74]. Particular importance is given to the analysis of the relationship between the dynamics of process parameters and the defect apparition on the final product. The analysis and modelling of the main data bank assumes the prediction and the monitoring of the faults and their effect on the slab quality. Alarms are set forth when a fault or defect is predicted and the necessary correction and adaptation will be achieved [68, 73, 75-76].

In this thesis the followings aspects have been developed:

- Prediction of final chemical composition and the temperature of liquid steel in the ladle as a function of additions, this constitutes a soft sensor. Prediction using neural networks model achieves good results comparatively to the conventional model based on analytical and statistical approach. This prediction is an important tool for optimising the mass of additions and the temperature. Non-linearities, thermal losses and noise are taken into account.
- Improvement of the breakout prediction system using neural networks is clearly proven in chapter 4 using the EKO STAHL breakout database. False alarms generated by the fluctuating temperatures in the copper mould are cancelled. These results are obtained by experience from earlier databases based on real and false alarms. This model takes into account breakout propagation in the space of the mould and in the time according to the temperature variation.

- Closed loop stabilisation of surface temperature using conventional PID and neural networks control algorithms are developed in chapter 5. This new closed loop control achieves a stable surface temperature. The control algorithm can be connected to the different existing heat conduction models. Simulation results are carried out by a simplified heat transfer model. The robustness of the control algorithm is tested using some changes in the process parameters such as casting speed and water temperature.
- Quality monitoring and classification is developed in chapter 6 on the basis of the importance of breakouts which is connected to the breakout detection system. This technique achieves a classification of different defects according to different alarms given by the breakout prediction system. For example a breakout detected by many alarms achieves an important defect as compared to that detected only by one alarm. This constitutes a guide tool for the quality classification. Fault detection is also developed using a neural networks model. Conventional modelling cannot establish a complex non-linear relationship between alarm state (0-1) and historical dynamic process parameters such as casting speed and motor current. This technique has been applied at SIDER Group in Algeria. This allows to find out as soon as possible the equipment defect using a real-time data acquisition system. The model is implemented on the process computer using graphical programming by “Labview” software.



### 1.3 Process parameter analysis and control

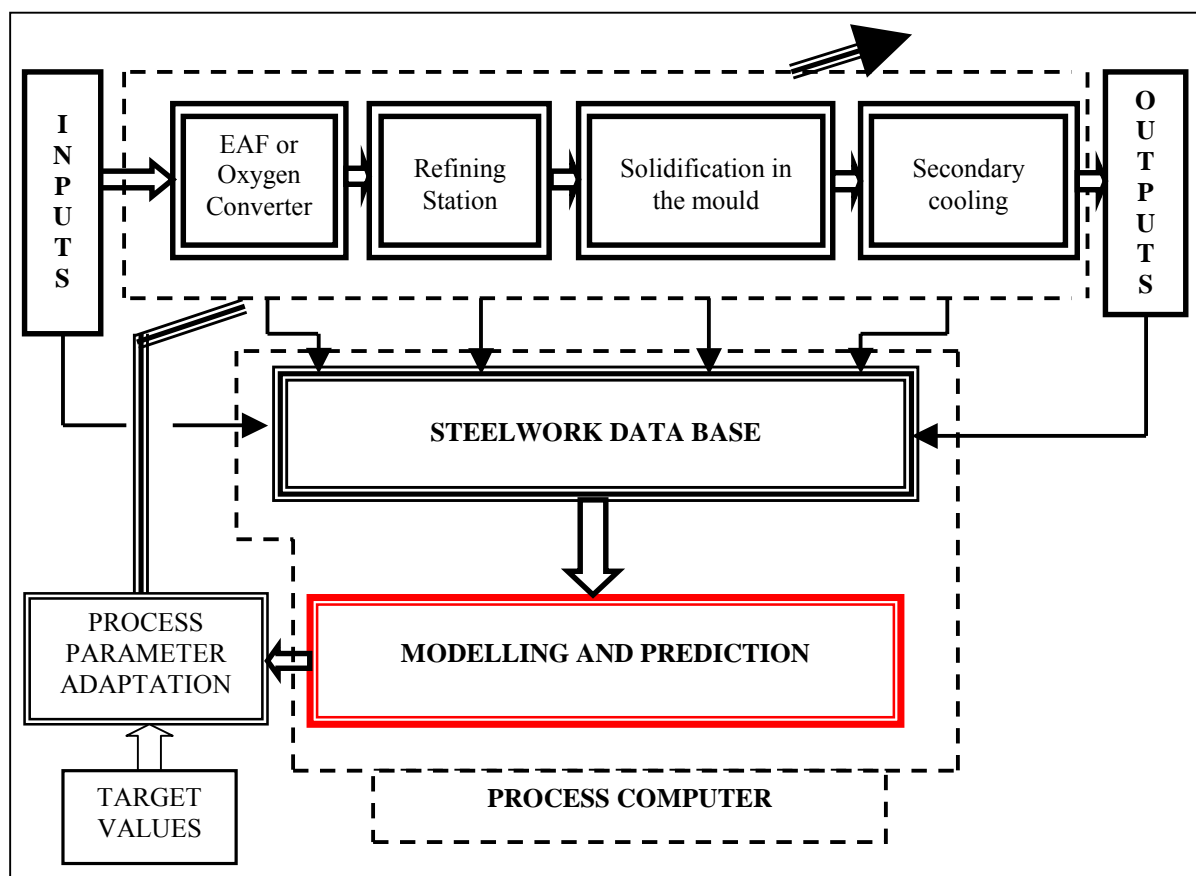


Fig. 1.3: Principle of process monitoring and control

In practice the steelmaking process every day generates a lot of information related to raw materials, energy, quality, process parameters, machine parameters, reliability etc. This constitutes an important database (**Fig. 1.3**) which provides a prerequisite to obtain the desired prediction models. The exploitation of abnormal operating conditions can provide an interesting information about the process dynamics. Optimal operating conditions must be found based on the process output and prediction capability. The database is generally filtered to eliminate the data affected by the noise. The predicted values obtained by the modelling process are compared to the target values and the necessary adaptation will be realised which is operated by different process set points. In the first elaboration process (EAF or Oxygen Converter), we consider liquid steel with an acceptable chemical composition and temperature. Importance is given to the refining and continuous casting processes because these constitute the latest step in the steel plant. More details will be developed in this thesis.

Computer aided production management is an important skill today. In the major production process, computerised management and control constitute an important tool to optimise production and quality. The development of communication network has eased the expansion of computerised production and optimisation, particularly for comprehensive systems where it is necessary to undertake a distributed data processing [75-77]. The global process is divided into many subsystems. Each sub-system is processed by its own algorithm and computer. The data bank exchange between different sub-systems is carried out by the communication network. Today, computer performance achieves real-time data processing and executes the optimisation algorithm to reduce the production cost. The modelling of the input-output interactions is an important tool for the research of the optimisation algorithm. This algorithm allows an optimal adaptation of the control parameters to achieve the optimisation objective. When the model for the inputs–outputs is defined around the operating point, the optimal decision will be achieved by a closed loop called: "Loop of continuous amelioration". The continuous amelioration closed loop is a unified approach that may be applied to any system or process. The computerised implementation seeks to implement this principle as a numerical and logical model. The data processing can be realised in real-time or in off-line operation, this depends on the calculation and the sampling time. Sometimes, different processes are geographically dispatched, in this case the communication network is used to transfer data. The process monitoring of critical parameters which has an important impact on the production uses different methods of modelling such as neural networks. The data acquisition is obtained by an analog to digital device for the measured process parameters and by the specified terminal for other types of data and information. The local processing unit executes the limited computing task such as the execution of the regulation algorithm (PI; PID) around the set point. It is also considered in this part of sequential task. This doesn't allow a long computing time. The local processing considers the algorithm in the field of the binary and sequential control and stabilisation of the process. The objective is to assume a stable control loop. The host process computer that executes the optimisation algorithm gives the set points with optimal values. In this case the local information is transferred to the host computer, which has a sufficient computing capability. The production management computer, the process computer and the local processing units are connected via network for exchange of information. The network has a high transmission rate and noise rejection. All processing units and terminals are inter-connected. Generally, the mathematical models are executed by the process computer [14-15, 77-78].

## 2 MATHEMATICAL MODELLING

System and process are characterised by the complex interactions between the input and output variables. There are many mathematical modelling approaches. In this thesis, particular models are developed for easy application in the on-line control and optimisation. Unfortunately, these systems are very complex by their structural and parameter changes such as non-linearity and unsteady state behaviour [34, 44, 67, 79]. In these operating conditions, conventional models such as linear modelling appear limited to achieve a high performance for these processes. Hence, on-line adaptation according to the process parameter changes must be performed [79-87]. Another aspect related to models validation must be considered since physico-chemical models based on energy and mass balances feature some difficulties on the validation using the measurement data. Sometimes, it is difficult to find the optimal values of the physical parameters assuming a minimal error between the model and the measurement; this reduces the precision of modelling. Models based on the identification techniques particularly those using neural networks improve the prediction by reducing the modelling error. This approach uses direct raw data. This process allows us to define inputs and outputs of the model. Multilayered neural networks fit the non-linear Multi-Input and Multi-Output Process (MIMO). Process interactions are taken into account by the interconnectivity of the neurones between different hidden layers [87-97]. The aim of this section is to review the different modelling methods and control using mathematical modelling. Particular importance is given to the NN approach.

### 2.1 Conventional modelling

The importance of conventional modelling is particularly its use for the design and off-line simulation. On-line implementation of this modelling approach is particularly limited by its long computing time. To reduce this, it is sometimes necessary to use special computing techniques.

Generally, the conventional modelling is based on energy and mass balances. The steady state balance can be obtained by the following equation:

$$Q_i(t)^{input} = Q_i(t)^{output} \quad (2.1)$$

and the dynamic equilibrium conditions can be written as:

$$\Delta q_i^E(t) = Q_i(t)^{input} - Q_i(t)^{output} \quad (2.2)$$

Equations (2.1) and (2.2) are valid for the mass and energy balances.

$$Q_i(t)^{input} = f_i^1(t, u_i(t), u_i(t - \Delta t), \dots, y_i(t), y_i(t - \Delta t) \dots) \quad (2.3)$$

$$Q_i(t)^{output} = f_i^2(t, u_i(t), u_i(t - \Delta t), \dots, y_i(t), y_i(t - \Delta t) \dots) \quad (2.4)$$

$$q_i^E(t) = f_i^3(t, u_i(t), u_i(t - \Delta t), y_i(t), y_i(t - \Delta t) \dots) \quad (2.5)$$

The differential analysis of different equations gives a non-linear differential system. In the linear case, these equations will be linearised around the operating point of each variable. The linearisation process induces inevitably model precision losses. The numerical implementation is obtained by a discretisation of the differential operator defined by the following approximation

$$\Delta q_i^E(t) \approx q_i^E(t) - q_i^E(t - \Delta t) \quad (2.6)$$

$\Delta t$  is the sampling time. After transformation we obtain a recurrent model defined by:

$$F(t, u_i(t), u_i(t - \Delta t), \dots, y_i(t), y_i(t - \Delta t) \dots) = 0 \quad (2.7)$$

**Fig. 2.1** defines the structure and the interactions between different process variables.

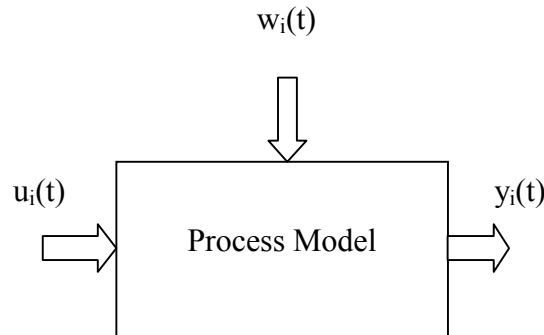


Fig. 2.1: Process model structure

$t$ ,  $u_i(t)$ ,  $w_i(t)$  and  $y_i(t)$  are the time, process inputs, disturbance and process outputs respectively,  $w_i(t)$  is a random perturbation.

### 2.1.1 Identification models [48, 88, 98-100]

The conventional identification technique permits to find the process parameter vector using the minimum least square error between the process output and model output according to the dynamical data. We consider a process with dynamic output and exogenous input; this model is called Autoregressive Moving Average with eXogenous inputs (ARMAX). Each predicted output can be written as:

$$A(q^{-1})y(t) = B(q^{-1})u(t) + C(q^{-1})w(t) \quad (2.8)$$

$$A(q^{-1}) = 1 + a_1q^{-1} + a_2q^{-2} + \dots + a_nq^{-n} \quad (2.9)$$

$$B(q^{-1}) = b_0 + b_1q^{-1} + b_2q^{-2} + \dots + b_mq^{-m} \quad (2.10)$$

$$C(q^{-1}) = c_0 + c_1q^{-1} + c_2q^{-2} + \dots + c_pq^{-p} \quad (2.11)$$

$n$ ,  $m$  and  $p$  is the differentiation order for the output, the input and the exogenous input respectively which are defined according to the process dynamics.

The objective is to find optimal values of the process parameters using a least square algorithm. The principle of identification is given by the scheme below (**Fig. 2.2**).

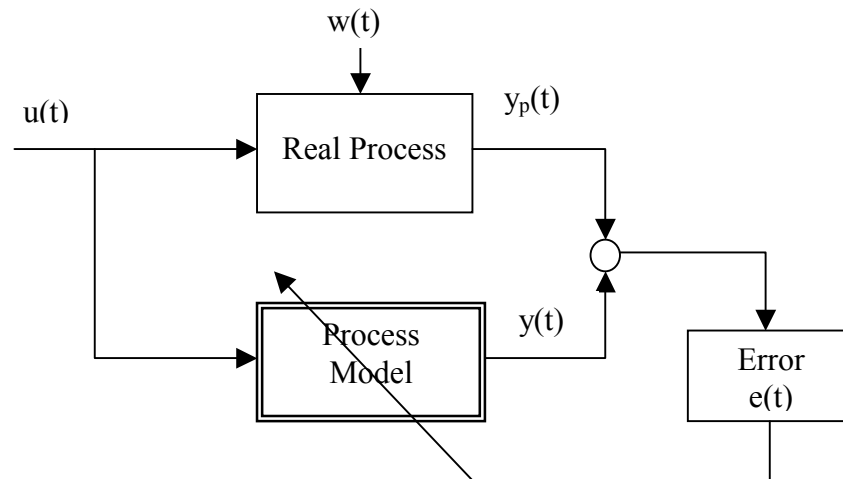


Fig. 2.2: Model identification principle

From equation (2.8), the model output can be written as:

$$y(t) = X(t)^T \theta(t-1) \quad (2.12)$$

with:

$$X(t) = [y(t-1), y(t-2), \dots, y(t-n), u(t-1), \dots, u(t-m), w(t-1), \dots, w(t-p)]^T \quad (2.13)$$

$$\theta(t) = [a_1, a_2, \dots, a_n, b_1, \dots, b_m, c_1, c_2, \dots, c_p]^T \quad (2.14)$$

The prediction error can be defined as:

$$e(t) = y_p(t) - X(t)^T \theta(t-1) \quad (2.15)$$

The identification objective is to find the process parameters that minimise the sum of errors  $e(t)$ .

$$\text{Min}\{J\} = \left\{ \sum_{k=0}^t e(k) \right\} \Rightarrow \theta(t)_{\text{optimal}} \quad (2.16)$$

The following form gives the recursive estimation of vector parameters:

$$\theta(t) = \theta(t-1) + P(t)X(t)e(t) \quad (2.17)$$

where:

$$P(t) = \frac{1}{\lambda(t)} \left[ P(t-1) - \frac{P(t-1)X(t)X(t)^T P(t-1)}{\lambda(t) + X(t)^T P(t-1)X(t)} \right] \quad (2.18)$$

The forgetting factor  $\lambda(t)$  is usually computed according to the rule

$$\lambda(t) = \lambda_0 \lambda(t-1) + 1 - \lambda_0 \quad (2.19)$$

$$P(0) = I/\alpha, \quad \alpha \ll 1 \quad (2.20)$$

Recursive estimation can be defined as:

### Step1: Initialisation

- Define:  $\theta \in \mathfrak{R}^{N \times 1}$ ,  $P \in \mathfrak{R}^{N \times N}$ ,  $X \in \mathfrak{R}^{N \times 1}$ ,  $I = \text{Diag}(N \times N)$ ,  $y(0), u(0) \dots$
- $P_0 = I/\alpha$ ,  $\alpha \ll 1$
- $\theta_0 = [0 \ 0 \ 0 \ \dots \ 0]^T$
- $\lambda_0 = 0.95$

### Step2: Recursive estimation

- Input/output data acquisition
- $X(t) = [y(t-1), y(t-2), \dots, y(t-n), u(t-1), \dots, u(t-m), w(t-1), \dots, w(t-p)]^T$
- $y(t) = X(t)^T \theta(t-1)$
- Compute  $e(t)$  Equ(2.15)
- Compute  $\theta(t)$  Equ(2.17)
- Compute  $\lambda(t)$  Equ(2.19)

- Compute  $P(t)$  Equ(2.18)
- Assign  $w(t)=e(t)$
- If  $t=t_{\max}$ : Go to **step 3**
- Else  $t=t+1$  and Go to **step 2**

**Step3: END**

After the convergence of the identification algorithm, the estimated process parameters  $\theta(t)=\theta_0$  are used to synthesise the control law, i. e, the PID tuning values.

### 2.1.2 Process control

Conventional or classic closed loop control is used for the process output stabilisation around the set point. In the industry, generally, the Proportional Integral and Derivative (PID) algorithm is used.

The identification results are used only for tuning the PID controller parameters in off-line. Many conventional process control approaches based on linear modelling have been applied, but they remain limited and don't assume the necessary optimisation particularly for complex processes with regard to:

- time variant process parameters
- models with high non-linearities
- It is more important when the optimisation objective is based on the prediction of the product characteristics that are not directly measured by sensors but determined by quality classification (defect, type and importance of the defects). In this situation advanced approach of the production database analysis and modelling must be considered.

## 2.2 Neural network modelling [48, 90-102]

Advanced process control and monitoring require accurate process models. The development of analytical models from the relevant physical and chemical knowledge, especially complex processes with phase changes, can be too costly or even impossible. For such process models based on process production operational data should be capitalised. Many industrial processes exhibit non-linear dynamic behaviour and non-linear models should be developed. Neural

networks have been shown to be able to approximate continuous non-linearity and have been applied to non-linear and complex process modelling. Network training results in a “Black Box” representation in which the model developed can be difficult to be analysed. The complexity is due to the large number of network weights. In practice, many non-linear processes are approximated by reduced order models, possibly linear, which are clearly related to the underlying process characteristics.

## 2.2.1 Neural network identification and modelling

### 2.2.1.1 Problem formulation and back-propagation learning

We consider dynamic systems which are governed by the following non-linear relationship:

$$y(t) = f[y(t-1), \dots, y(t-n), u(t-1), \dots, u(t-m), w(t-1), \dots, w(t-p)] \quad (2.21)$$

**Fig. 2.3** shows the identification and modelling principle.

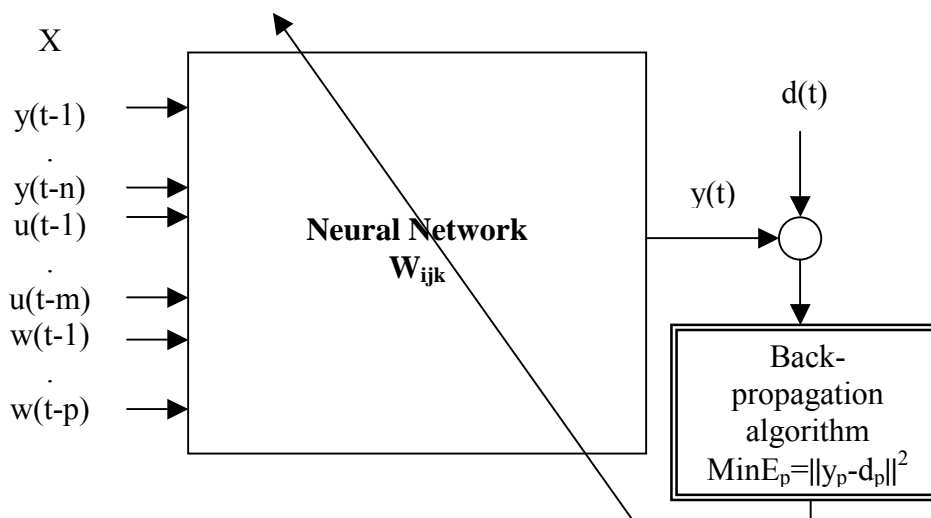


Fig. 2.3. Principle of neural network learning process

The Back-Propagation (BP) algorithm is explained in detail by different works [48]. This process is briefly summarize here, the network to be trained consists of  $L$  layers of nodes, as shown in **Fig. 2.4**. The  $k^{\text{th}}$  layer contains  $N_k$  nodes, and for  $L=k$ , one “bias” node is obtained whose activation is always 1. Weighted branches exhaustively interconnect adjacent layers. The weight  $W_{ijk}$  refers to the branch from node  $i$  in layer  $k$  to node  $j$  in layer  $k+1$ . The first



layer contains the network input  $X$  and the last layer the network output  $y$ . In the forward propagation node,  $X$  is given, and each node in the second and subsequent layers calculates the activation  $z$  as an exponential function of the sums of weight of its inputs.

$$z_{jk} = \frac{1}{1 + e^{-u_{jk}}} \quad (2.22)$$

where

$$u_{jk} = \sum_{i=1}^{N_{i-1}+1} z_{i,k-1} W_{i,j,k-1} \quad (2.23)$$

The network outputs are the activations of the last column  $z_L$ .

In the learning mode, training examples which consist of  $p$  input/output vector pairs  $(X_p, d_p)$  are given. The objective is to select weights that minimise the sum of squared errors between the net predictions  $y_p$  and the desired outputs specified by the overall training examples  $d_p$ :

$$\min_W J = \sum_{p=1}^P E_p \quad (2.24)$$

where  $E_p$  is the sum of squared errors associated with a single training example:

$$E_p = \|y_p - d_p\|^2 \quad (2.25)$$

During learning, the network is initialised with small random weights on each branch. A training example is selected randomly, and the input vector  $X_p$  is propagated through the network to get the predicted output  $y_p$ . A gradient in the space of network weights is then calculated using the Generalised Delta Rule (GDR). The GDR gives the steepest descent direction  $m_p$  associated with the training example  $p$ :

$$m_{ijk} = \delta_{j,k+1} z_{ik} \quad (2.26)$$

Where  $m_{ijk}$  is the component of the gradient associated with  $W_{ijk}$ . For the output layer  $L$ :

$$\delta_{i,L} = (d_j - y_j) y_j (1 - y_j) \quad (2.27)$$

Where  $1 \leq j \leq N_L$  and for other layers,

$$\delta_{ik} = z_{ik} (1 - z_{ik}) \sum W_{ijk} \delta_{j,k+1} \quad (2.28)$$

Where  $1 < k < L - 1$  and  $1 \leq i \leq N_k$

Using the gradient  $m_p$ , the weight changes on step  $q$ ,  $\Delta_q W$ , are calculated according to the following formula:

$$\Delta_q W = \eta m_p + \alpha \Delta_{q-1} W \quad (2.29)$$

In this expression two constants appear,  $\eta$  called the learning rate which is equivalent to a step size, and  $\alpha$  which acts as a momentum term to keep the direction of descent from changing too rapidly from step to step. After the weights have been updated, a new training example is selected and the procedure is repeated until satisfactory reduction of the objective function is achieved.

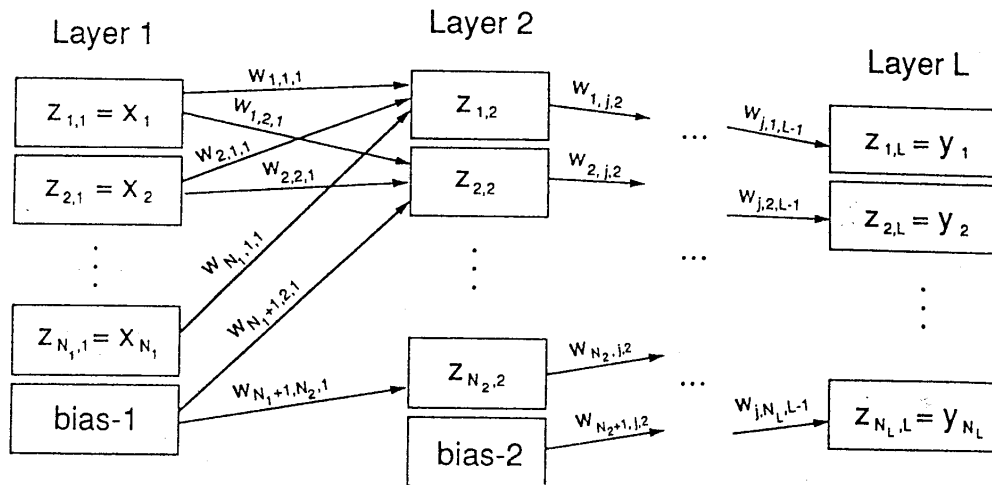


Fig. 2.4: Neural network architecture and weight indexing

### 2.2.1.2 Learning algorithm

The following computing steps constitute the learning algorithm:

**Step1:** Initialisation of the network weights

**Step2:** Learning process

- Acquisition of inputs/outputs
- Compute the model output equ(2.22, 2.23)
- Compute the errors equ(2.26, 2.27, 2.28)
- If  $E_p \ll 1$ , save weights go to step3
- Else adapt the network weights equ(2.29) and go to step2

**step3:** END

## 2.2.2 Neural process control

Neural network is a tool used to describe the input/output relationship and the first step is to use the NN to identify the process model. Many techniques were developed for application in the field of control and optimisation design. The objective is to obtain optimal control inputs that minimise the sum of quadratic error between the desired outputs on the one hand and predicted output on the other hand. Several training and control methods have been developed [48, 101-108]. Assuming that the system to be controlled can be described by equation (2.21), the desired network is the one that isolates the most recent control input  $u(t)$ ,

$$u_p(t) = f_p^{-1}[y(t+1), \dots, y(t-n+1), u(t-1), \dots, u(t-m+1), w(t), \dots, w(t-p+1)] \quad (2.30)$$

and can be used for controlling the process by substituting the output at time  $t+1$  by the desired output  $r(t+1)$ .

A specialised training approach defined by the control scheme in **Fig. 2.5**, that minimises a criterion of the following type, is developed:

$$J(\theta, \phi) = \frac{1}{2N} \sum_{t=1}^N [r(t) - y(t)]^2 \quad (2.31)$$

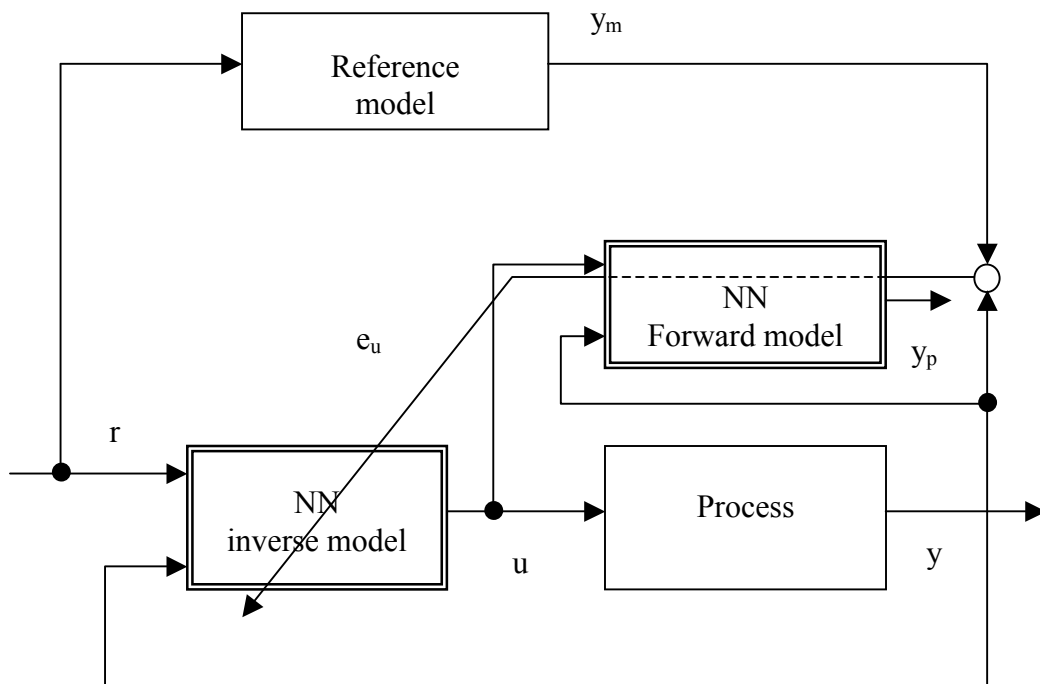


Fig. 2.5: Overall structure of inverse model control

Inspired by the recursive training algorithms the network might alternatively be trained to minimise the relation

$$J_t(\theta, \phi(t)) = J_{t-1}(\theta, \phi(t-1)) + [r(t) - y(t)]^2 \quad (2.32)$$

This is an on-line approach and therefore the scheme constitutes an adaptive controller. By way of introduction, a recursive gradient method is considered. Assuming that  $J_{t-1}$  has already been minimised, the weights are adjusted at time  $t$  according to the following formula:

$$\theta(t) = \theta(t-1) - \mu \frac{de^2(t)}{d\theta}, \quad (2.33)$$

where  $e(t) = y_m(t) - y(t)$ ,  $y_m(t)$  is the reference model output [48] and

$$\frac{de^2(t)}{d\theta} = -\frac{dy(t)}{d\theta} e(t) \quad (2.34)$$

By application of the chain rule the gradient  $\frac{dy(t)}{d\theta}$  can be calculated as

$$\frac{dy(t)}{d\theta} = \frac{\partial y(t)}{\partial u(t-1)} \frac{du(t-1)}{d\theta} \quad (2.35)$$

$$= \frac{\partial y(t)}{\partial u(t-1)} \left[ \frac{\partial u(t-1)}{\partial \theta} + \sum_{i=1}^n \frac{\partial u(t-1)}{\partial y(t-i)} \frac{dy(t-i)}{d\theta} + \sum_{i=2}^m \frac{\partial u(t-1)}{\partial u(t-i)} \frac{du(t-i)}{d\theta} \right] \quad (2.36)$$

It appears that the Jacobians [48] of the system,  $\frac{\partial y(t)}{\partial \theta}$ , are required. These are generally unknown since the system is unknown. To overcome this problem an estimation is given as follows:

$$\frac{\partial y(t)}{\partial u(t-1)} \cong \frac{\partial y_p(t)}{\partial u(t-1)} \quad (2.37)$$

The (simplified) specialised training can easily be implemented with the back-propagation algorithm. The back-propagation algorithm is used in the inverse model by assuming the following “virtual” error of the output of the controller:

$$e_u(t) = \frac{\partial y_p(t)}{\partial u(t-1)} e(t) \quad (2.38)$$

The on-line specialised control algorithm is summarised by the followings steps:

**Step1:** Data acquisition

- Read input/output data from the process

**Step2:** Control law computing

- Calculate the tracking error
- Calculate the virtual error

- Update weights with recursive form equ(2.29)

**Step3:** Go to step1

### 2.2.3 Neural process optimisation and monitoring

Process supervision is to bring a dynamical system from one global state to another. Its task differs severely from typical feedback control problems which concern the task to make the system output follow a given trajectory and to attenuate stochastic or “small” deterministic disturbances. **Fig. 2.6** illustrates the principle of monitoring

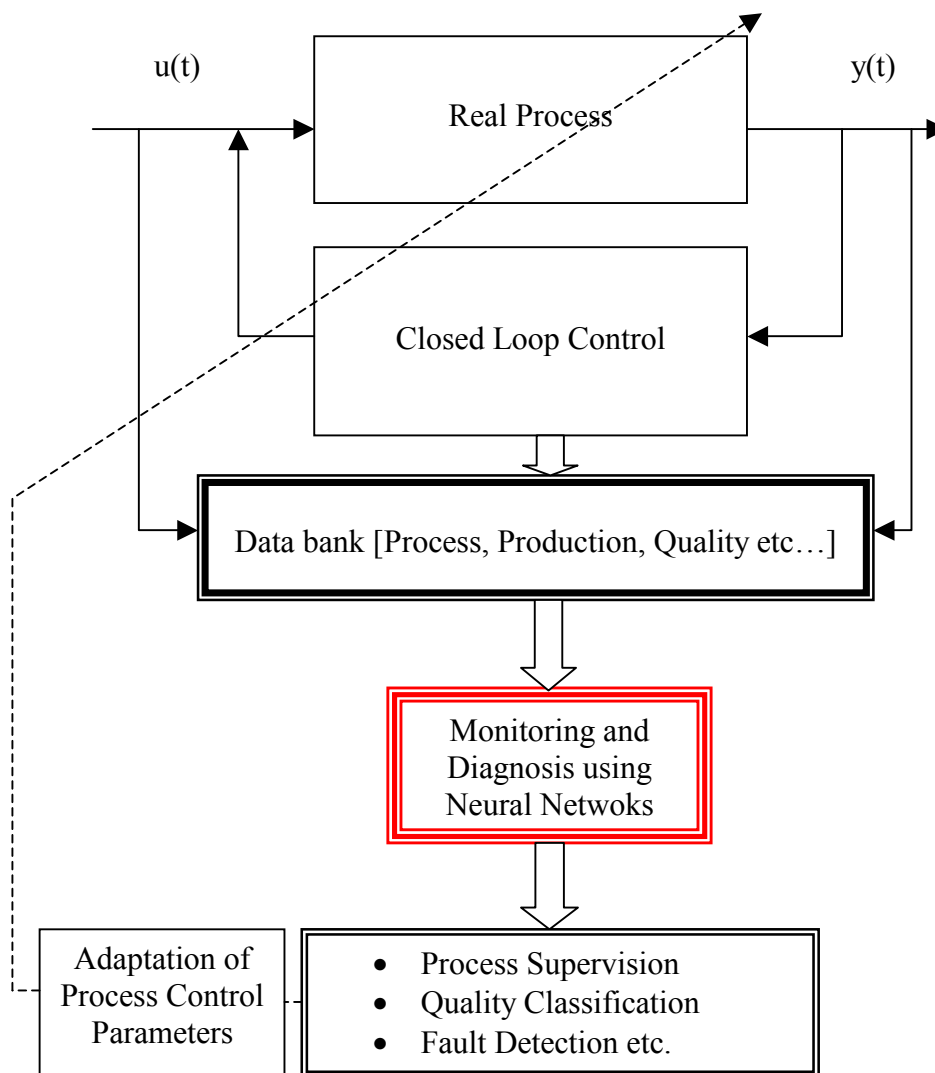


Fig. 2.6: Principle of process monitoring using adaptive scheme (NN)

## 3 MODELLING OF LADLE METALLURGICAL TREATMENT PROCESSES

### 3.1 Introduction

The principle of ladle treatment in SIDER (Algeria) is given in **Fig. 3.1**. After additions the homogenisation of chemical steel composition and temperature is carried out by blowing argon gas (1 bar). The slag is formed on the surface of the steel melt. Generally, ordinary and microalloyed steel grades are treated in the ladle.

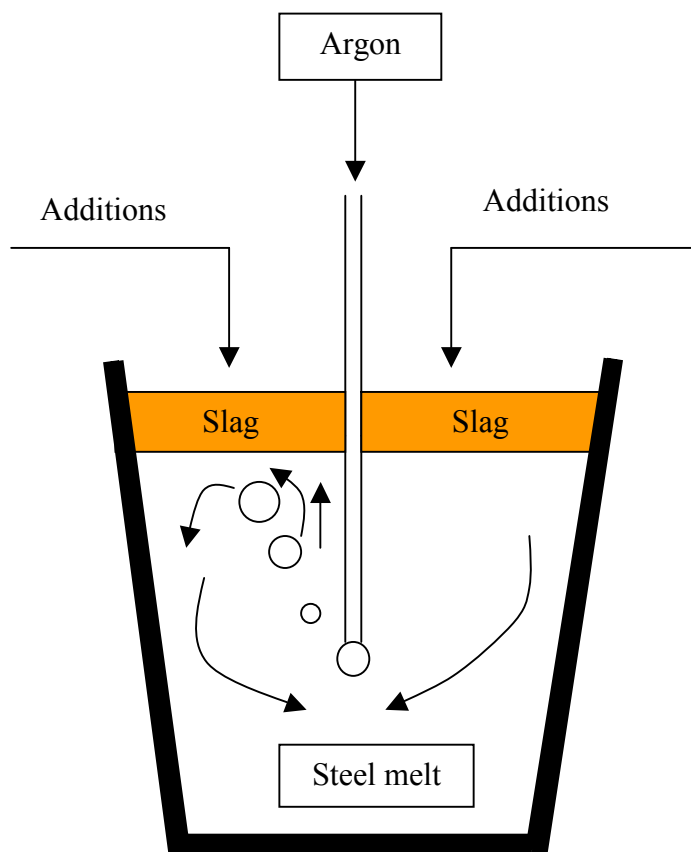
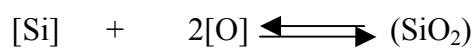


Fig. 3.1 Principe of ladle steel treatment

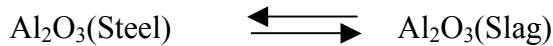
The followings reactions take place:

- Desoxidation by Refining Elements





- Separation of Oxide Inclusions



In steel industry, the refining process adjusts the final chemical composition and temperature of liquid steel by adding the optimal quantity of additions and energy. Generally a conventional charge calculation based on mathematical and thermodynamic models that provide considerable help is used, but it is difficult to model the highly complex nature of the interactions between process variables such as thermal losses and the dynamics of non-linear chemical reactions. Neural networks are able to identify internal relationships through training examples.

In this work, the application of identification models using linear approach and (NN) to predict the final chemical composition and temperature of the refining process is considered [48, 90, 100, 102]. Using an industrial process database, dynamics of complex reactions is modelled using the back propagation-learning algorithm. This model is used as a charge calculation to predict the final process parameters. The performance of the model is evaluated from new inputs and outputs. Production and quality cost management is reduced by an optimal control of the input variables such as the mass of additions (FeMn, FeSi and coke) and heating energy.

The aim of this section is to predict the process output for an optimal control of the process. This constitutes an important tool particularly for SIDER Group in Algeria where there are some problems with chemical analysis. Our investigation is based on the modelling and analysis of the database generated by this process. The main chemical reactions are the oxidation of the iron and the adjustment of manganese (Mn), silicon (Si) and carbon (C) contents in the liquid steel. Reactions are complex and depend particularly on the thermodynamic parameters. The final chemical composition of steel is adjusted by an optimal control of different input variables. In practice, sometimes the chemical reactions have not reached equilibrium and further operations are required to obtain the desired contents and temperature. These manipulations induce excess costs by an excess consumption of different additions and energy. Conventional charge calculations don't take into account different non-linear and random process changes. In this work an approach is considered based on NN to model the complex input and output relationships. Modelling of real process databases

considers different noise measurements, non-linearity of process and other complex properties [48, 109-112]. High prediction ability of the NN model improves the casting cycle and reduces the cost quality analysis and management in the steel plant. Thus the model can be used as a soft sensor. In our case the process inputs and outputs are defined as:

Input parameters:

- Different masses of additions (coke, FeMn, FeSi)
- Thermodynamic parameters (steel temperature)
- Initial chemical composition of liquid steel

Output parameters:

- Final liquid steel temperature or liquid steel temperature variation
- Final chemical composition or variation of chemical composition

All input and output data are used to define the NN parameters using the back-propagation algorithm that reduces the error between the target values and NN outputs. After convergence, the NN is used to predict the outputs using a new input database. The obtained model is used to compute the input according to the target outputs, i.e., liquid steel temperature and the final chemical composition.

### 3.2 Process description

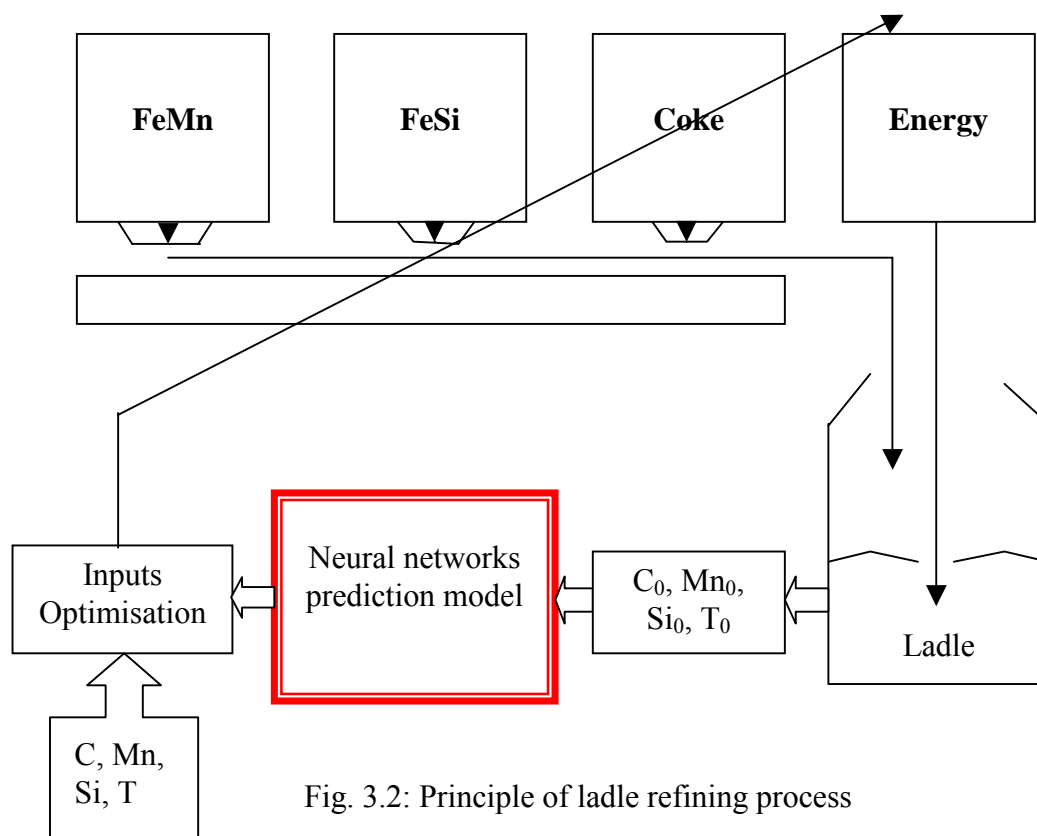
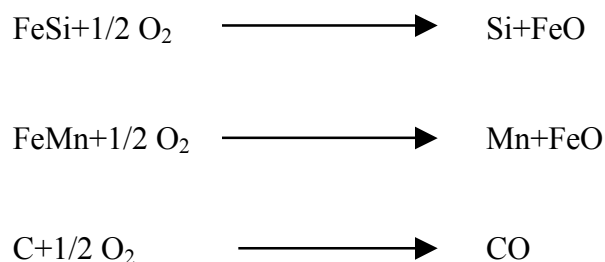


Fig. 3.2: Principle of ladle refining process



The principle of the refining process is given in **Fig. 3.2**. The ladle with liquid steel arrives in the refining station with the initial chemical composition and temperature. According to these initial values and the desired chemical composition and temperature, optimal quantities of additions (coke, FeMn, FeSi) are applied.

The main reactions are:



**Fig. 3.3** defines the main process reactions according to different inputs.

All chemical reactions are controlled by temperature and pressure according to the reaction equilibria and kinetics. In our case the pressure is constant.

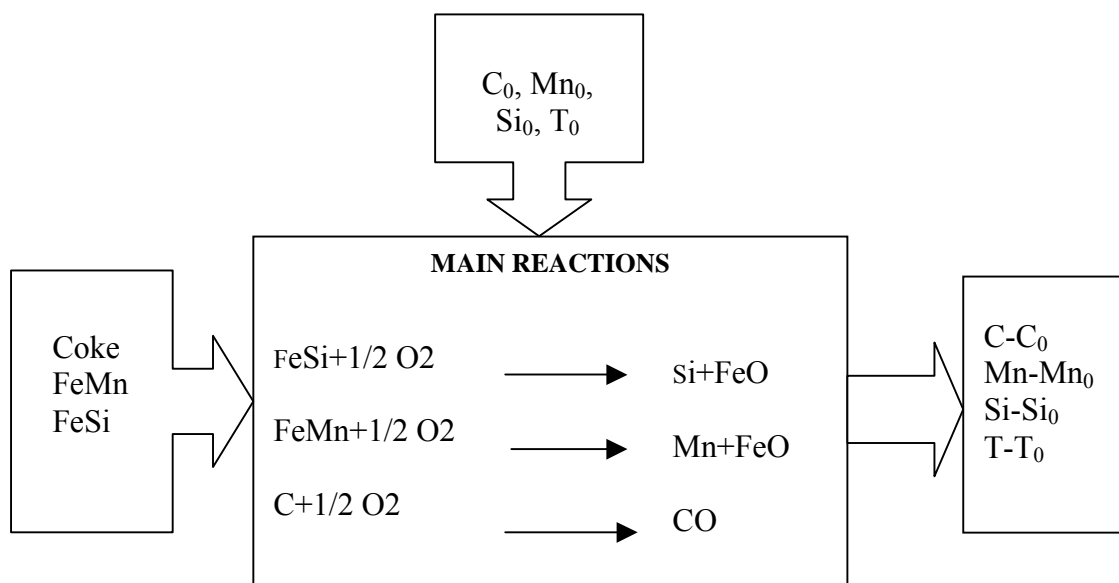


Fig. 3.3: Input/output interactions

The input parameters are:

$C_0$	:Initial carbon in the liquid steel	(%)
$Mn_0$	:Initial manganese in the liquid steel	(%)
$Si_0$	:Initial silicon in the liquid steel	(%)

$T_0$	:Initial temperature of liquid steel	(°C)
FeSi	:Added weight of ferro silicon	(kg)
FeMn	:Added weight of ferro manganese	(kg)
Coke	:Added weight of coke	(kg)

The output parameters are:

C	:Final carbon in the liquid steel	(%)
Mn	:Final manganese in the liquid steel	(%)
Si	:Final silicon in the liquid steel	(%)
T	:Final temperature of liquid steel	(°C)

The final temperature determines the casting condition. This temperature has limited values. When it falls below these limits the liquid steel is not recommended for continuous casting. Inputs and outputs of the process structure are used to define the NN architecture.

### 3.3 Process modelling and identification

#### 3.3.1 Linear model

A comparative study between the linear approach obtained by the iterative least square algorithm and the non-linear model based on the back-propagation algorithm is considered. The identification has been achieved using databases containing 100 raw samples. The input vector is defined as:

$$X=[C_0, Mn_0, Si_0, T_0, FeSi, FeMn, coke], \theta_i=[aC_{0i}, aMn_i, aSi_i, aT_{0i}, bFesi_i, bFeMn_i, bcoke_i]$$

and the output as

$$Y=[\Delta C, \Delta Mn, \Delta Si, \Delta T], Y(i)=y_i, i=1 \text{ to } 4.$$

A total of  $7 \times 4 = 28$  parameters are identified

where

$$\begin{aligned} \Delta C &= C - C_0 \\ \Delta Mn &= Mn - Mn_0 \\ \Delta Si &= Si - Si_0 \\ \Delta T &= T - T_0 \end{aligned}$$

The structure of this linear identification model is given in **Fig. 3.4**. All data are selected from real refining processes (SIDER - Algeria). The time series of input and output process variables are given in **Figs. 3.6 and 3.7**, respectively.

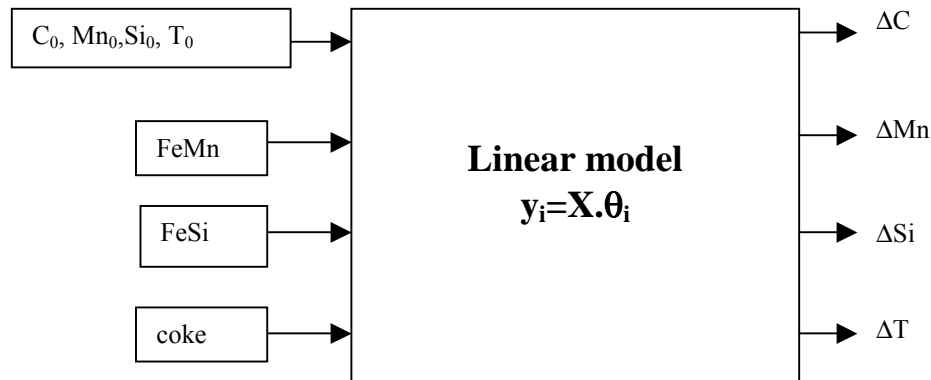


Fig. 3.4: Structure of linear identification model

### 3.3.2 Neural network model

**Fig. 3.5** gives the structure of the network. There are seven (07) inputs [ $C_0$ ,  $Mn_0$ ,  $Si_0$ ,  $T_0$ , FeSi, FeMn, coke], four (04) outputs [ $\Delta C$ ,  $\Delta Mn$ ,  $\Delta Si$ ,  $\Delta T$ ] and ten (10) neurones in the intermediate hidden.

The relationship between input and output parameters is defined as:

$$[\Delta C, \Delta Mn, \Delta Si, \Delta T] = NN[C_0, Mn_0, Si_0, T_0, FeMn, FeSi, coke] \quad (3.1)$$

This multi input-output model characterizes the complex relationships between different components. The approach considers the chemical reactions which are not easy to model using conventional methods.

The back-propagation algorithm adapts the parameters of the network in order to minimise the error between the output detected by the model and the desired output.

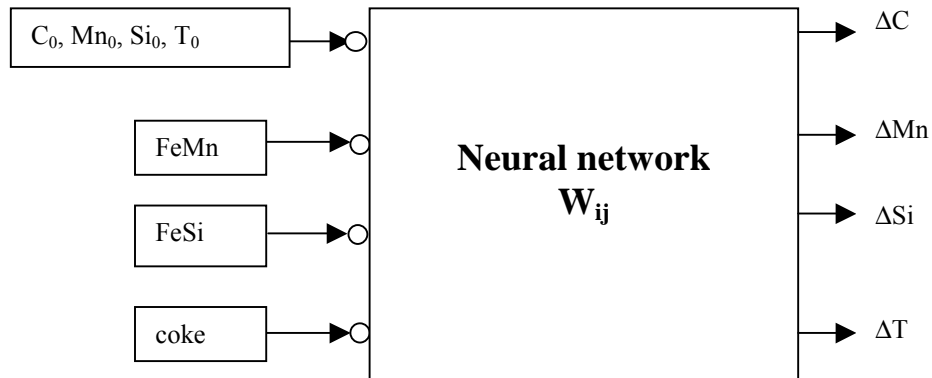


Fig. 3.5: Structure of identification using NN

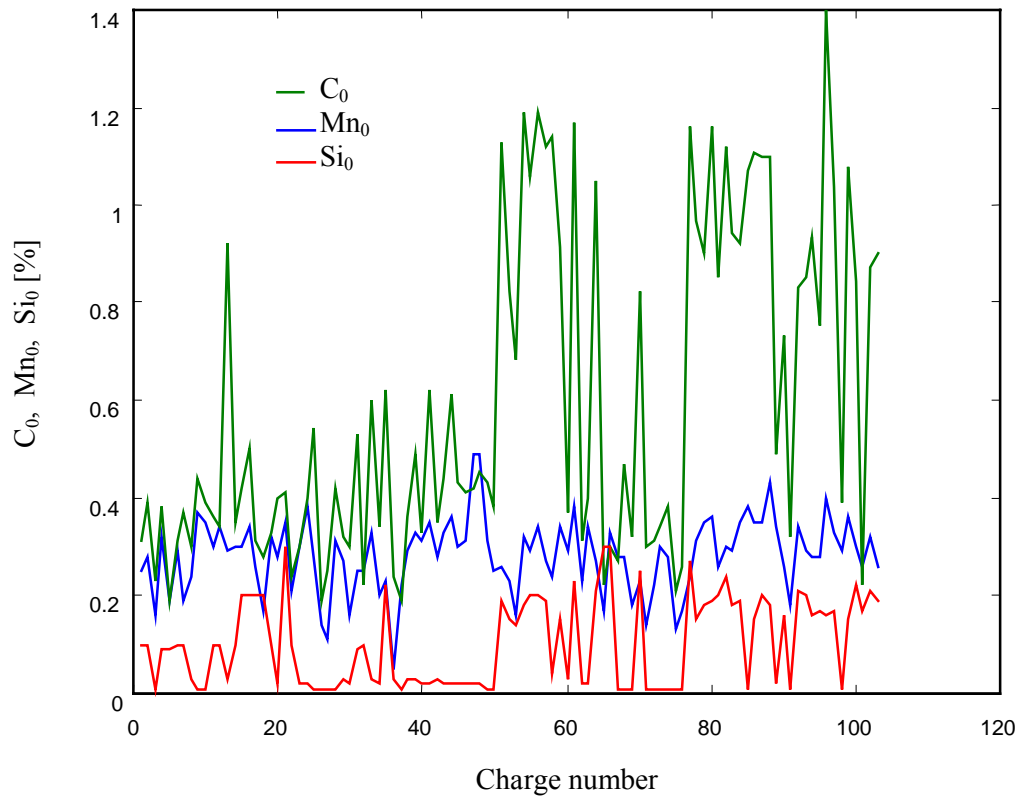


Fig. 3.6a: Initial chemical composition

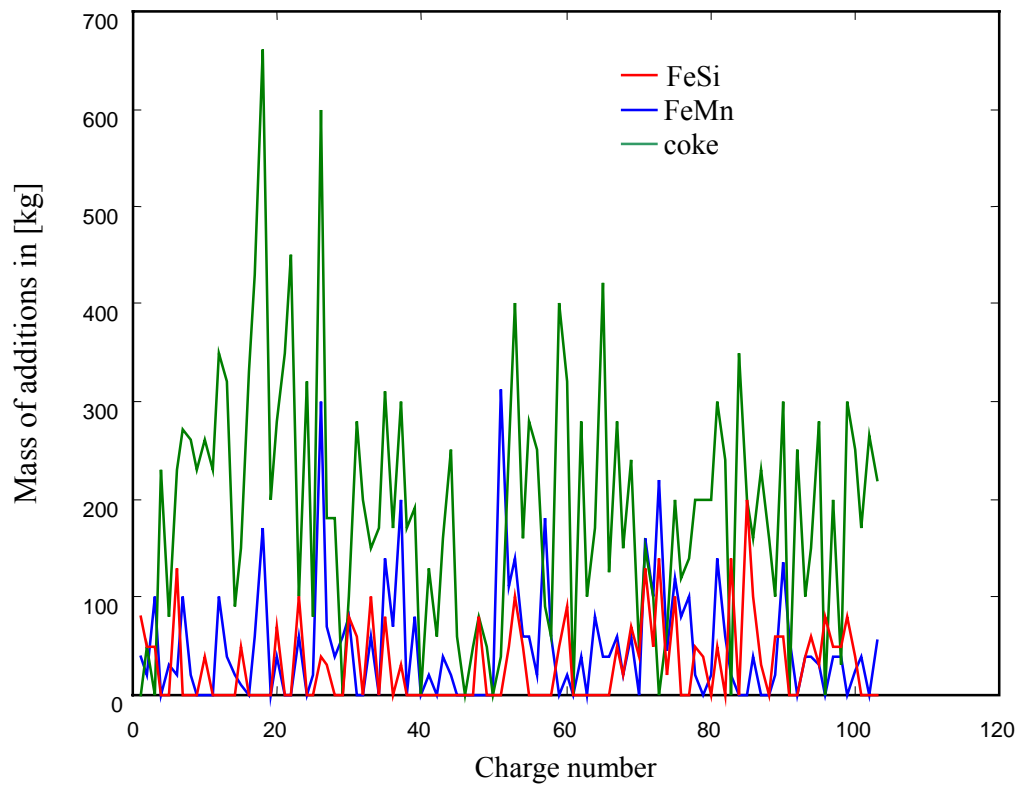


Fig. 3.6b: Evolution of weights of additions

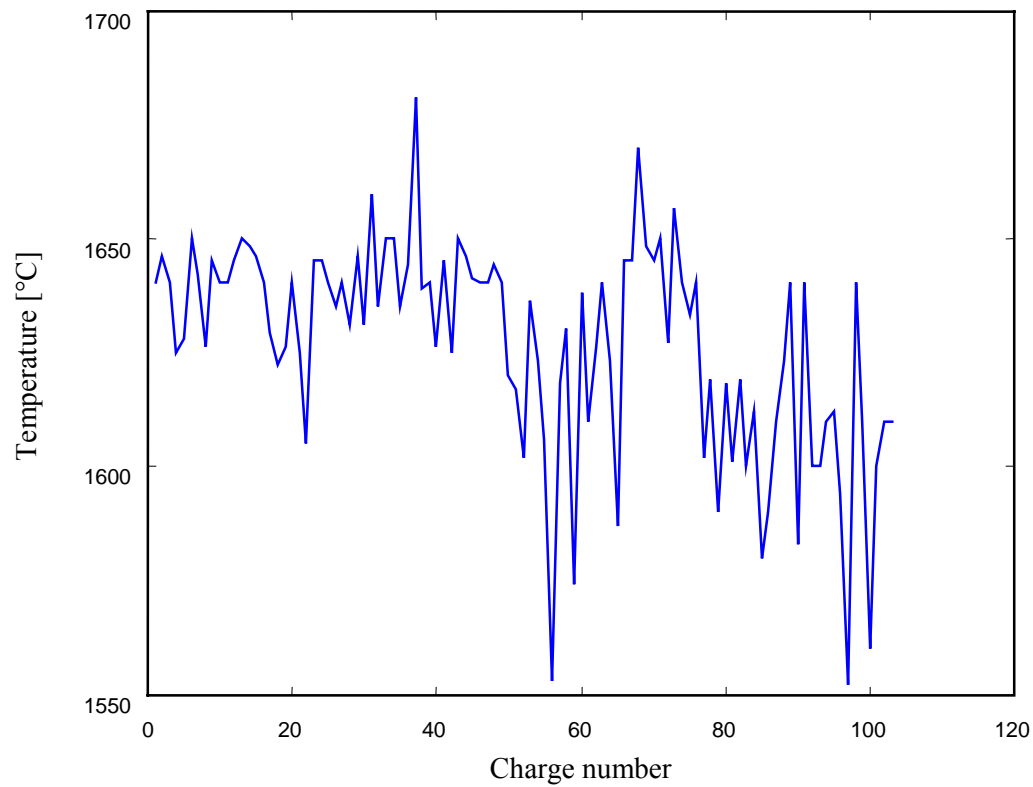


Fig. 3.6c: Evolution of initial temperature

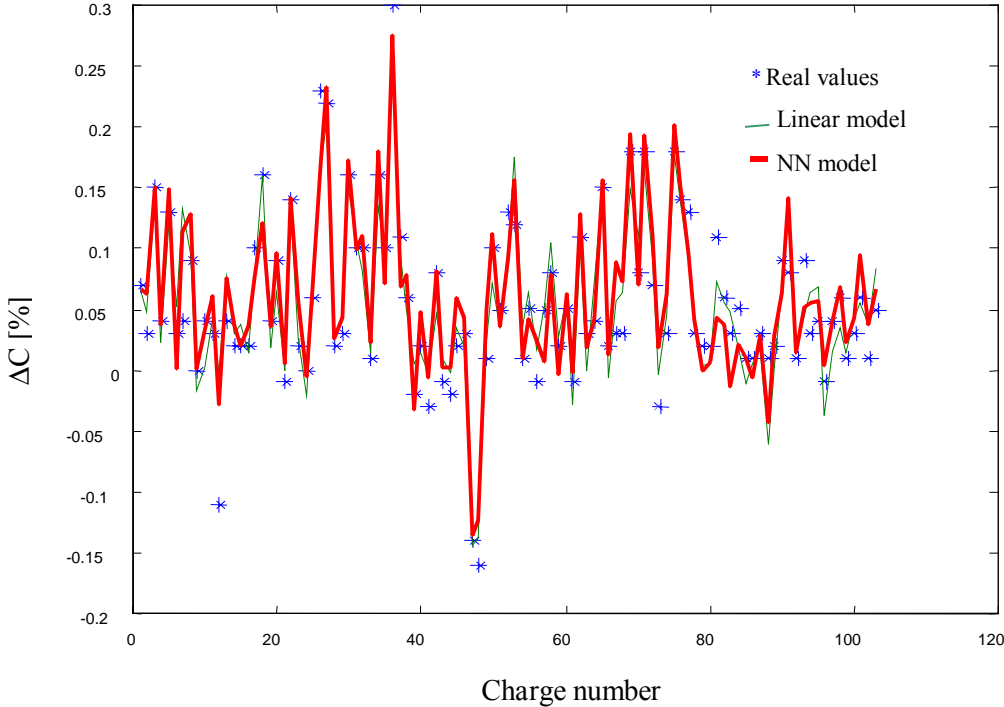


Fig. 3.7a: Real values and model identification of carbon

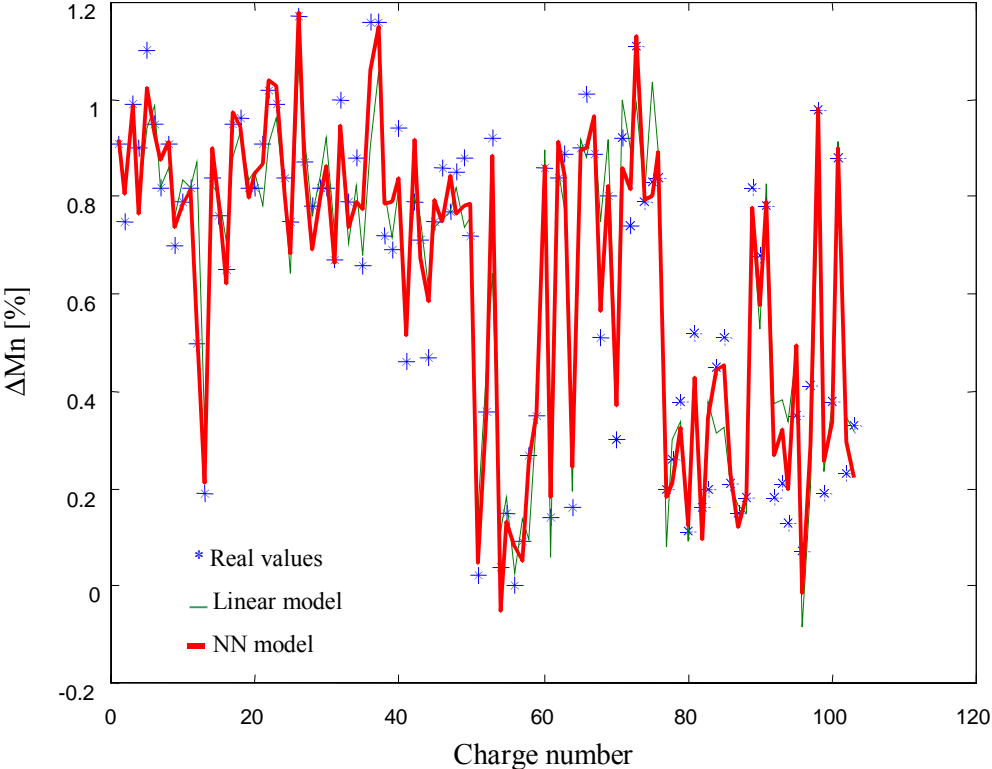


Fig. 3.7b: Real values and model identification of manganese

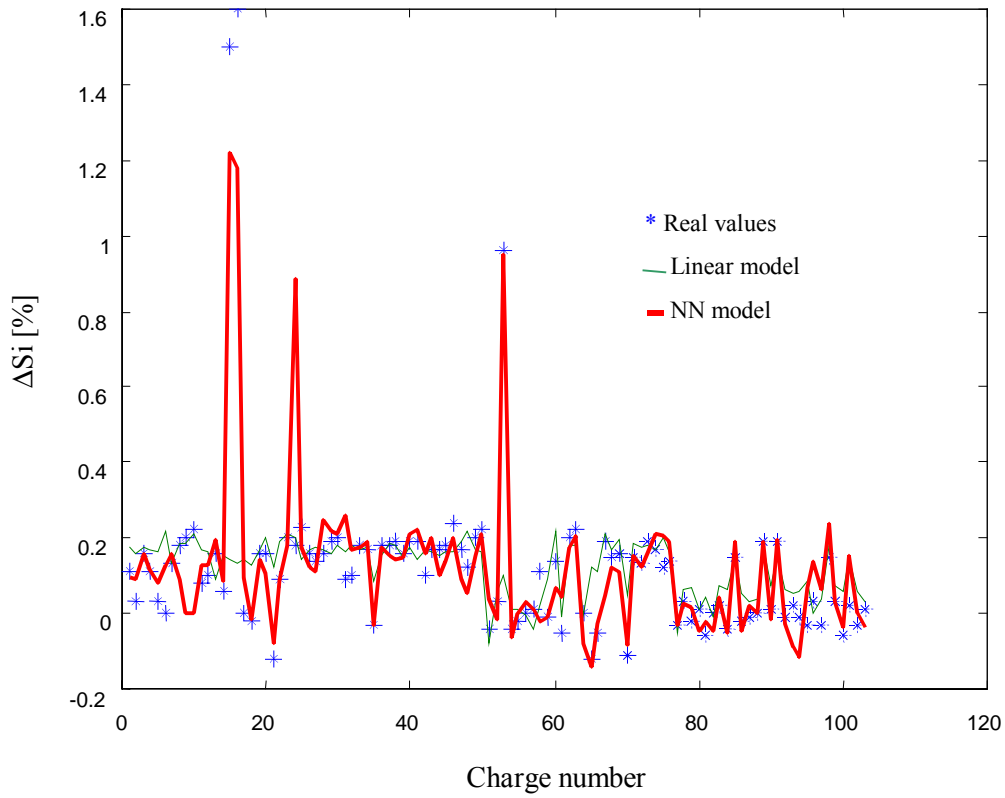


Fig. 3.7c: Real values and model identification of silicon

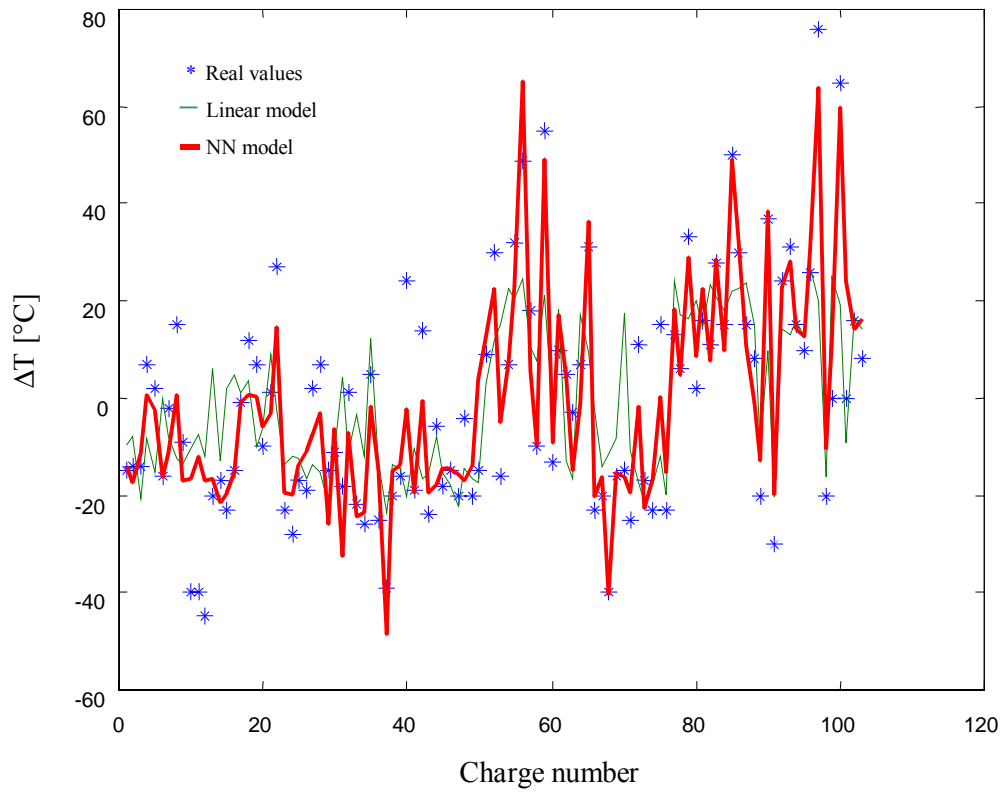


Fig. 3.7d: Real values and model identification of temperature

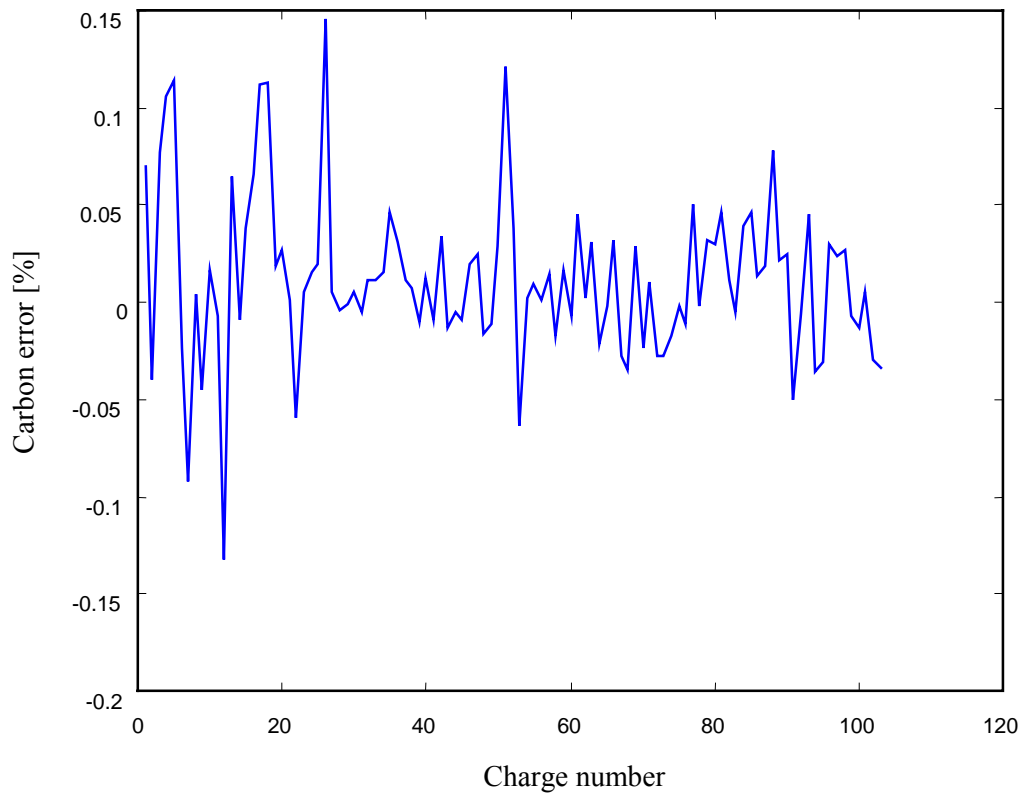


Fig. 3.7e: Carbon modelling error in the linear case

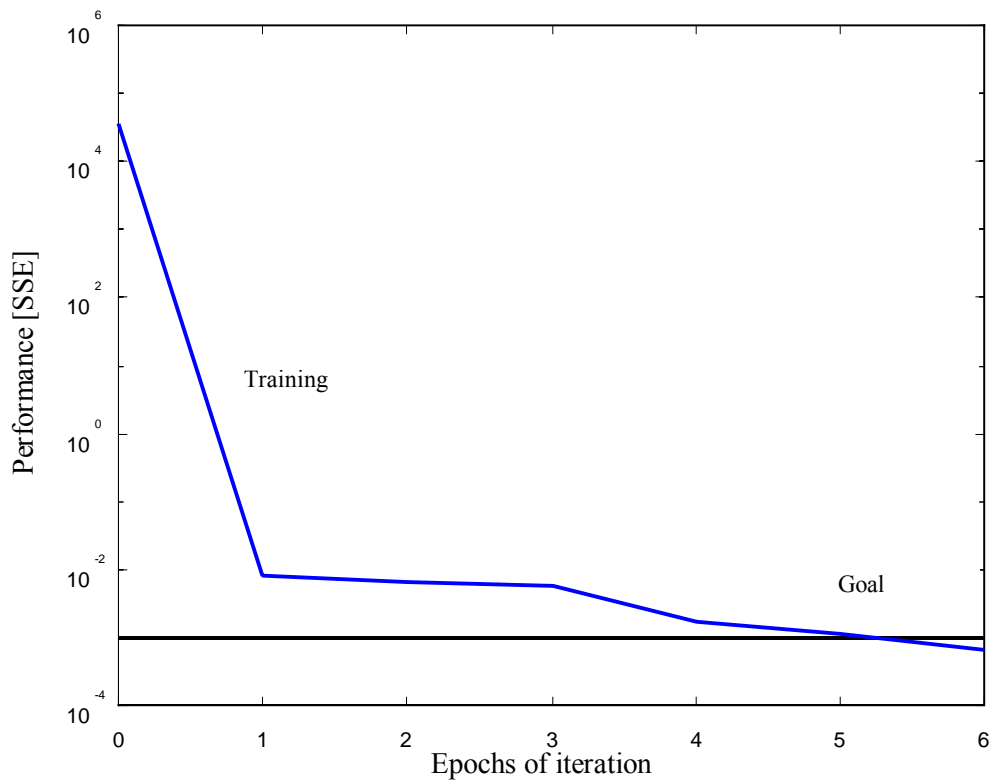


Fig. 3.7f: Carbon modelling performance using NN



### 3.4 Application

After off-line identification using NN and a linear model, models are used to predict the outputs using a new series of process data. **Figs. 3.8** and **3.9** give new process inputs and predictions, respectively.

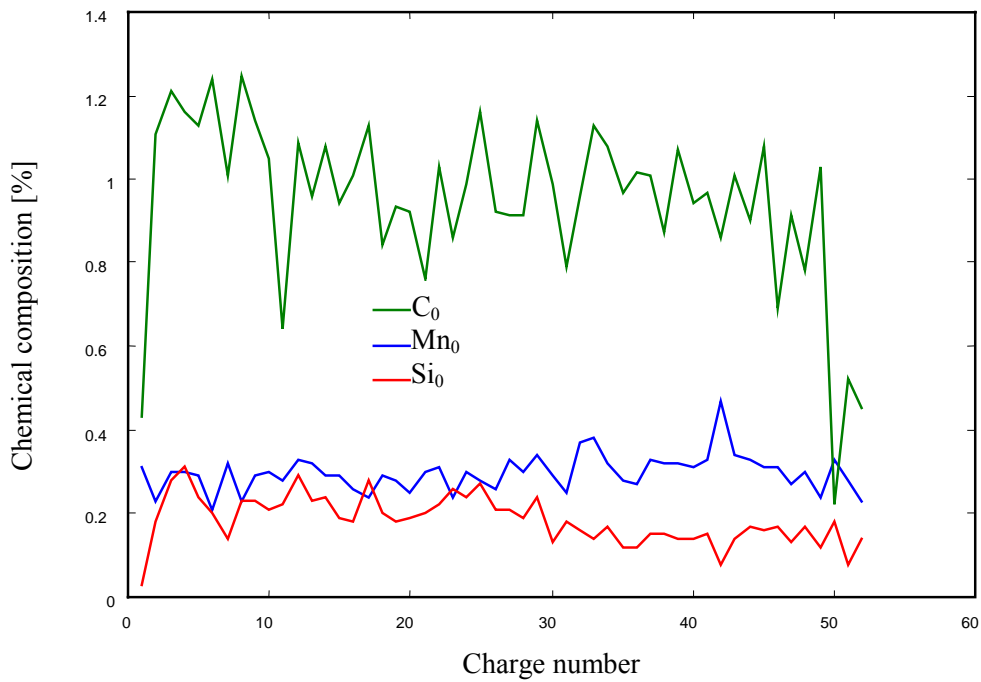


Fig. 3.8a: Evolution of initial chemical composition

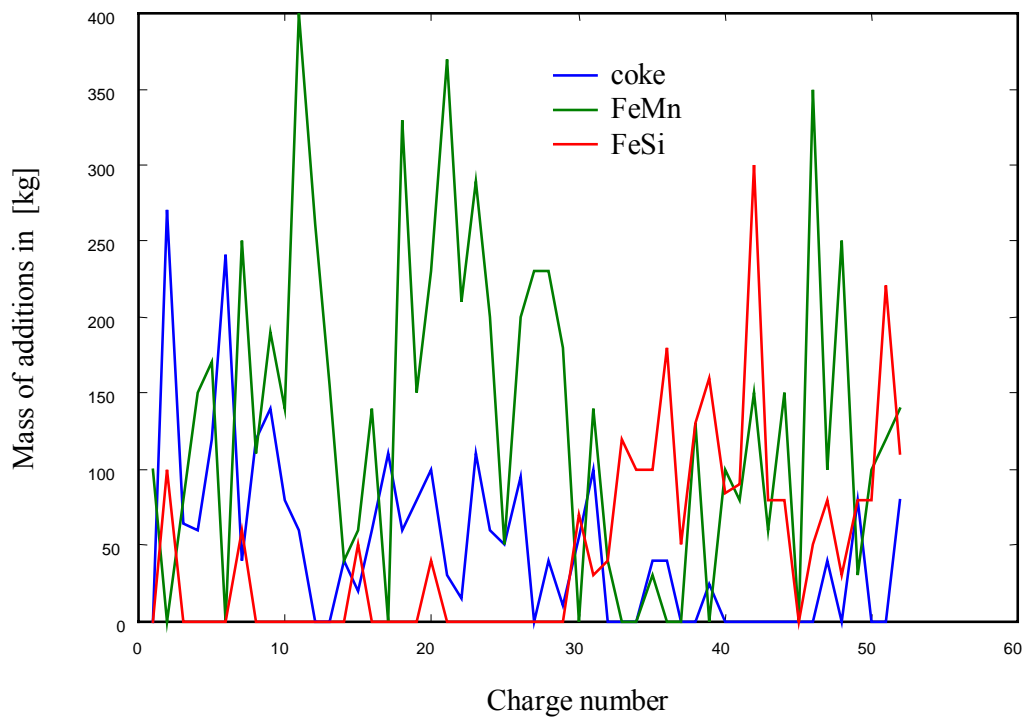


Fig. 3.8b: Evolution of additions

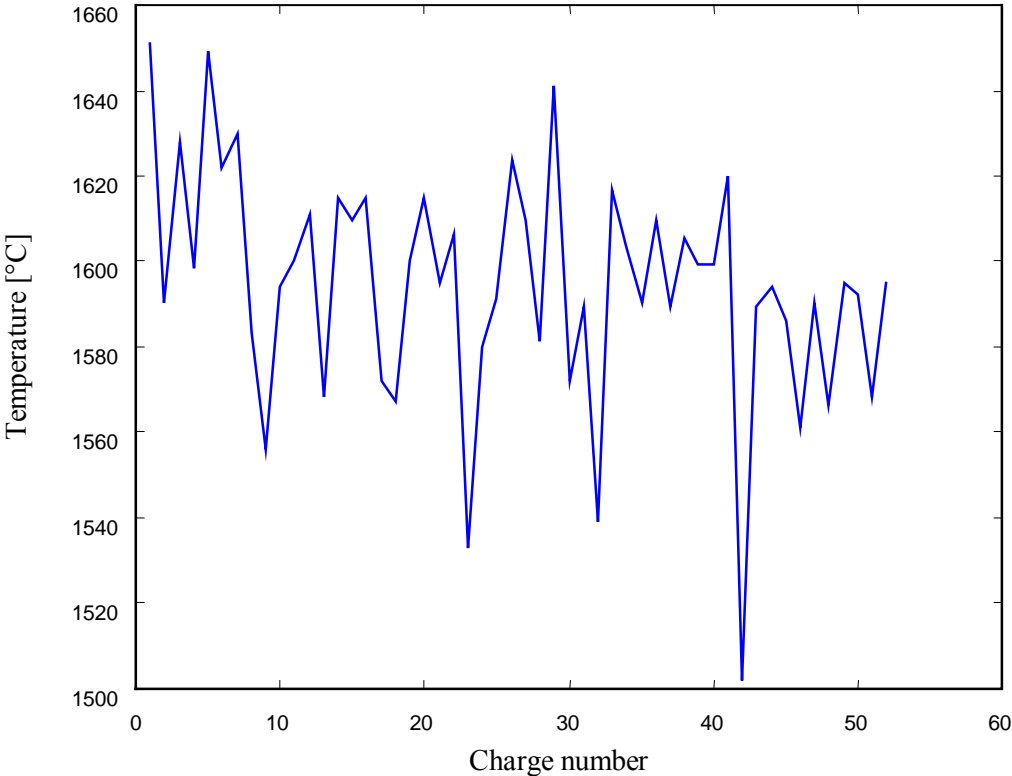


Fig. 3.8c: Evolution of initial temperature

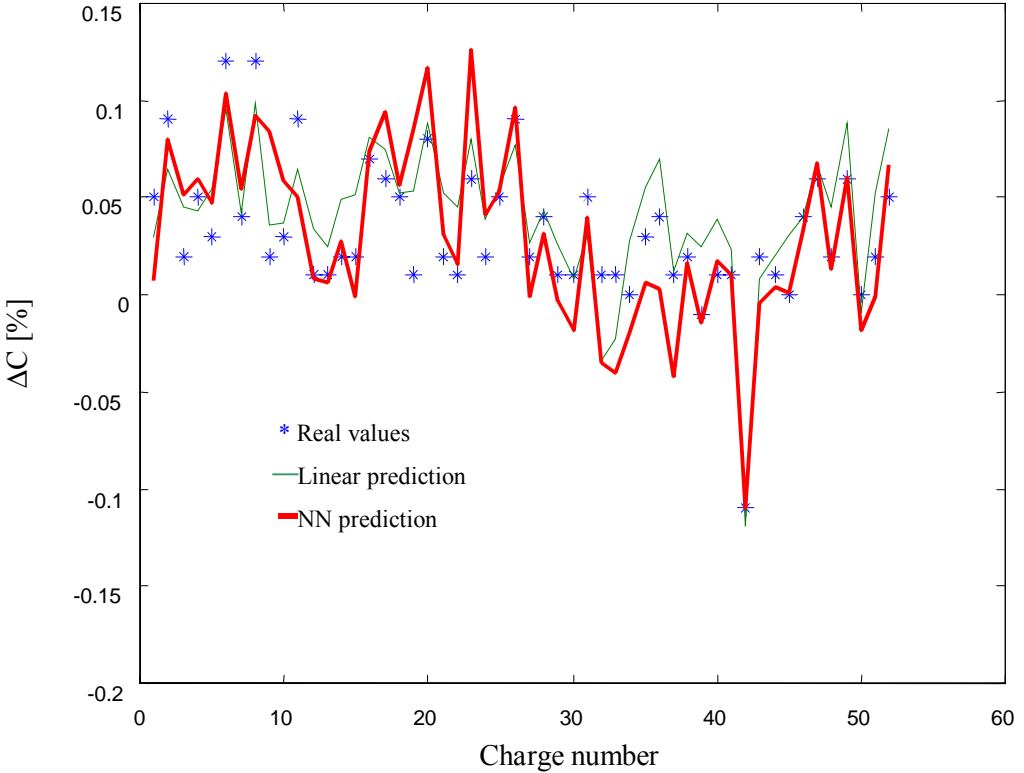


Fig. 3.9a: Real values and model prediction of carbon

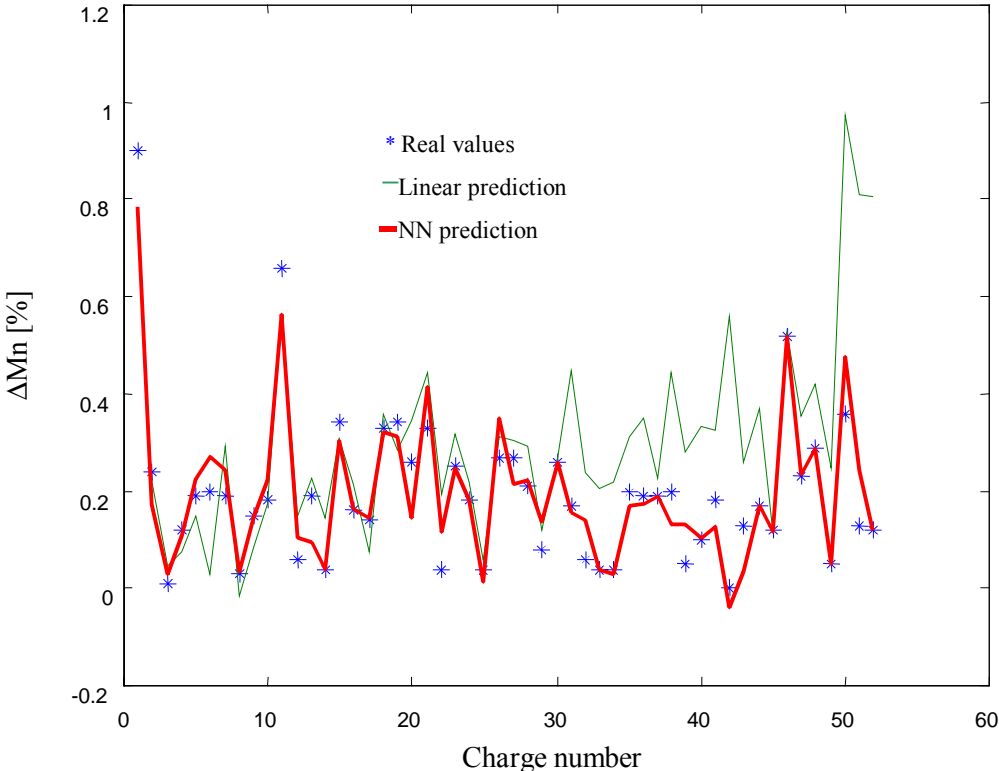


Fig. 3.9b: Real values and model prediction of managanese

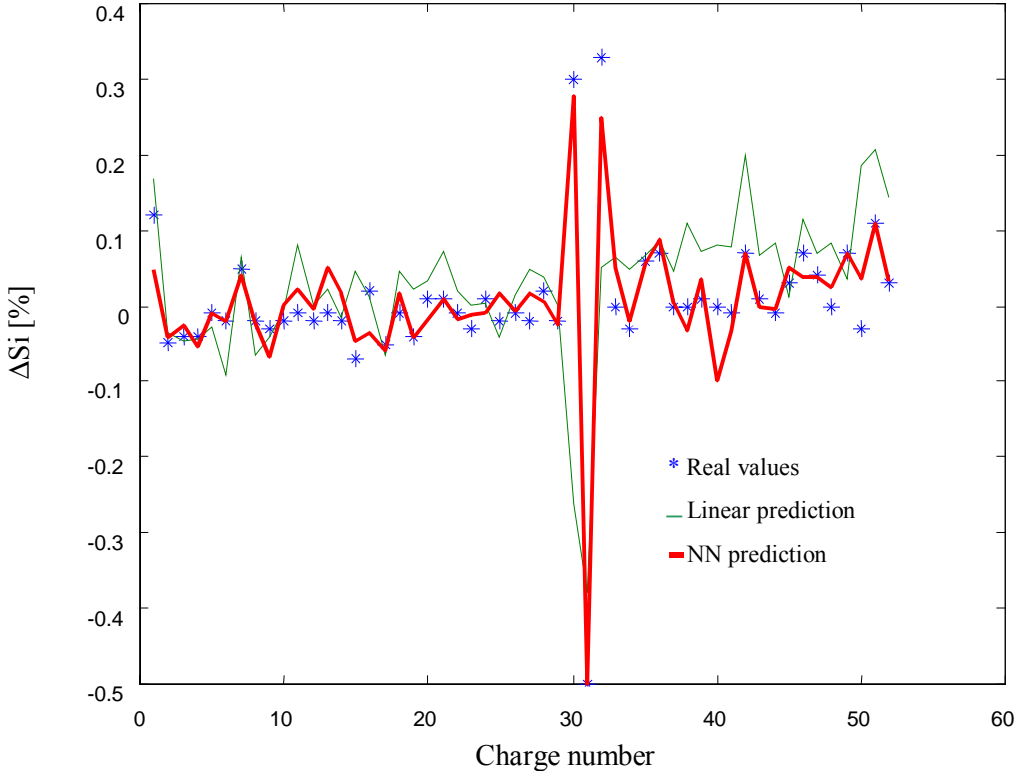


Fig. 3.9c: Real values and model prediction of silicon

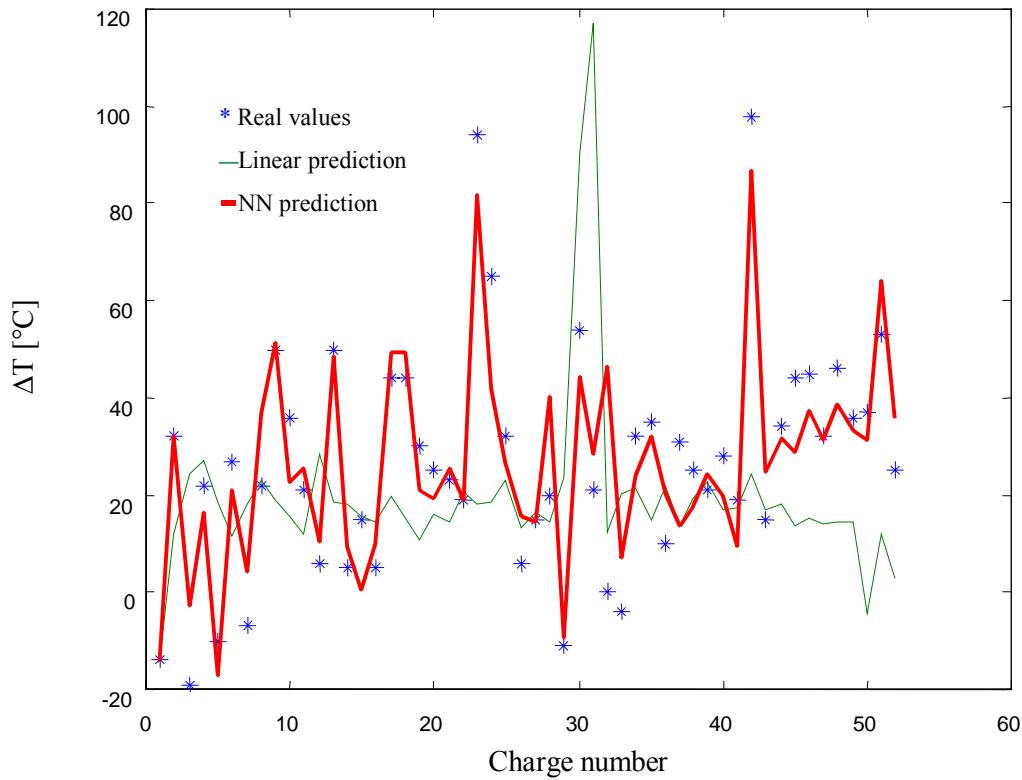


Fig. 3.9d: Real values and model prediction of temperature

### 3.5 Results and analysis

Model identification results by linear model and NN model respectively are summarised by the value of the sum of square errors ( $SSE = \sum e^2$ ) for each output in **Table 3.1**. Modelling errors using the NN model are better than those using a linear model. This improvement is also valid for the prediction.

SSE	[%C] <sup>2</sup>	[%Mn] <sup>2</sup>	[%Si] <sup>2</sup>	[T(°C)] <sup>2</sup>
<b>NN model</b>	0,0788	0,419	1.1563	8,817e03
<b>Linear model</b>	0,197	3,5027	9,5987	4,365e04

Table 3.1a: Sum Square Errors (SSE) in modelling

The mean modelling error of the temperature is defined as:

$$\Delta T_{\text{Mean}} = \sqrt{8,817e03 / N} = 93,9095 / 102 = 0,92 \text{ } ^\circ\text{C}$$

SSE	[%C] <sup>2</sup>	[%Mn] <sup>2</sup>	[%Si] <sup>2</sup>	[T(°C)] <sup>2</sup>
<b>NN model</b>	0,037	0,151	0,0521	6,5719e03
<b>Linear model</b>	0,026	2,329	0,6167	4,3973e04

Table 3.1b: Sum Square Errors (SSE) in prediction

The mean prediction error of the temperature is defined as:

$$\Delta T_{\text{Mean}} = \sqrt{6,5719e03 / N} = 81,0673 / 52 = 1,55 \text{ } ^\circ\text{C}$$

A method for the prediction of the final chemical composition and temperature has been developed using linear and NN models. Results obtained from new process data confirm that this method can be used as a soft sensor. More tests should be carried out before final application.

## 4 CONTROLLED SOLIDIFICATION IN CONTINUOUS CASTING MOULDS

The following developments have been realised on the EKO STAHL continuous casting process. The principle of this process is given in **Fig. 4.1**.

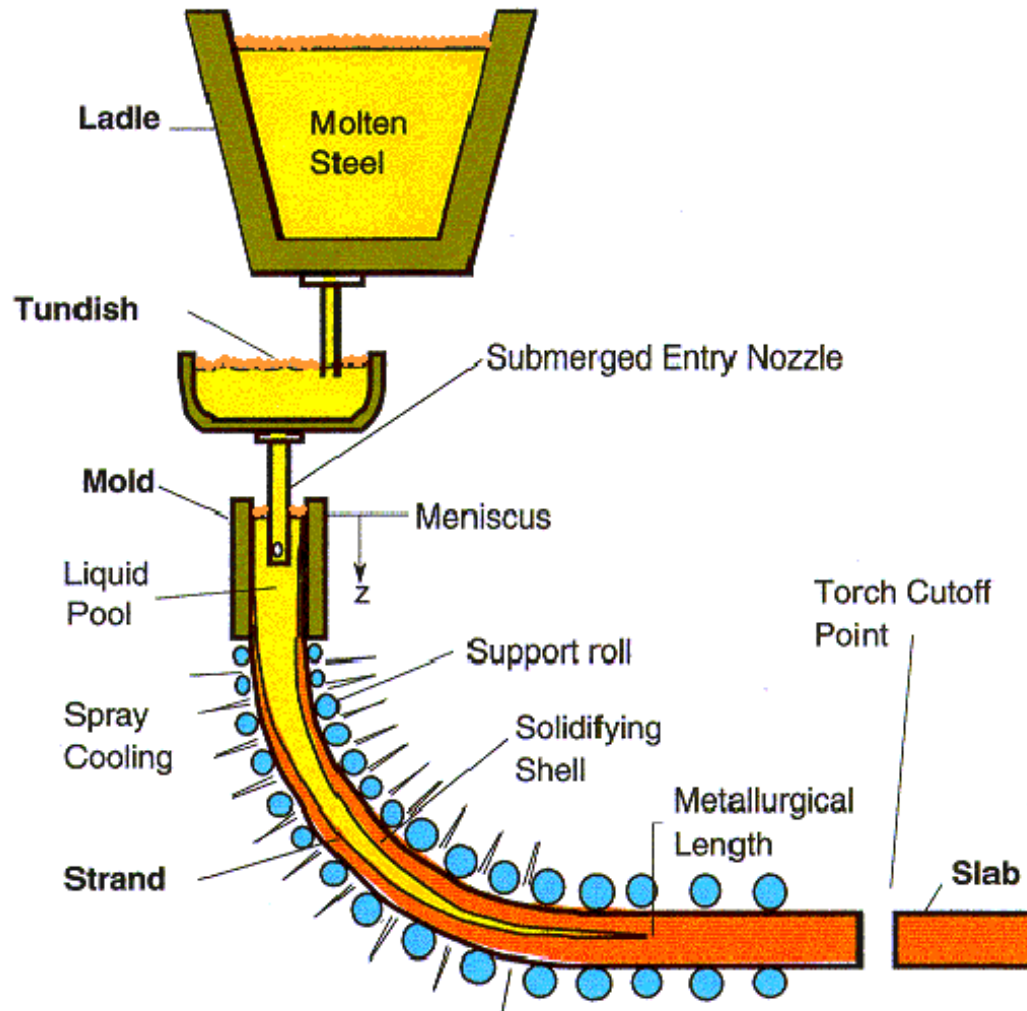


Fig. 4.1: Principle of continuous casting process [42]

The principal characteristics of this machine are defined as follows:

- VAI radial continuous casting machine (R=10 m, Slab Caster, 250 mm thickness)
- Instrumented mould by a matrix of thermocouples
- Conventional breakout detection system (BOY System)
- Controlled mould bath level and casting speed

- Six secondary cooling zones
- Compensation of casting speed effect on strand surface temperature by a feedforward using “Dynschell” model
- Format 850-1800 mm
- Casting speed (0 – 1.5 m/min)
- Slab thickness 250 mm
- Ordinary and microalloyed steel grades
- Contactless measurement of the slab width and temperature after cutting

#### 4.1 Control and monitoring of solidification in the mould

In the present study, Mould Thermal Monitoring (MTM) technology in continuous casting has been investigated in order to optimize casting control. The mould is the location of complex metallurgical reactions characterising the liquid–solid transformation forming the first crystals of solidification. Continuous measurements of the thermal profile are obtained by a matrix of thermocouples. In such a way, real-time monitoring and control of the process are considered. The control algorithm predicts solidification defects using mathematical models. In this work, a new approach for a breakout detection system has been developed by means of NN . A process database is used for training the NN using a back-propagation algorithm. The learning process uses modelled data samples related to the real alarm situations. After training the NN predicts new breakouts. Using this approach the number of false alarms will be considerably reduced comparatively to the conventional system.

In continuous casting, the phenomenon of the breakout is generally caused by rupture of the solid crust due to an increase in temperature at various points of the mould. Both peak and temperature oscillations have a direct influence on the quality resulting from solidification [31, 36, 42]. These phenomena appear at the time of slag incrustation, formation or propagation of cracks and in the case of poor friction and generally at the time of an imbalance of distributed thermal reactions in the mould. In this study, the monitoring and the detection of abnormal phenomena affecting thermal conditions in the mould have been developed using NN [48]. The structure and training process of the breakout prediction NN model are obtain as a result of temperature measurements that have been obtained from thermocouples fixed at the copper plates of the mould. The input of the time series network is formed by the measured temperature samples, while the output is formed by alarm defining the importance of defects. A new spatial network considers the combination of different time

series models alarm. The training has been carried out by the exploitation of databases characterising the normal and deteriorated operating conditions of solidification process. Such databases contain information on the dynamics of process parameters and the operating state of the process (alarms, shutdown of production,). In the following training, the simulation tests based on cases of real defects are applied to estimate the model detection ability.

## 4.2 Analysis of breakout phenomena

### 4.2.1 Breakout propagation process [31, 42, 63, 69]

The mechanism for the original sticking can be explained by the existing conditions at the meniscus such as variations of casting speed, mould bath level of liquid steel, steel temperature and lubrication. Changes of casting speed have an important influence. Procedures for start-up and speed changes have been altered to slowly ramp up the speed.

A breakout appears generally during metal sticking on the copper plate of the mould followed by perforation of the solid shell due to a solidification disturbance. Sticking breakout is propagated with various speeds in various directions and particularly in casting direction. **Fig. 4.2** shows an example of breakout propagation and **Fig. 4.2a** a little crack which has been developed in a breakout affecting the slab quality (see **Fig. 4.2b**).

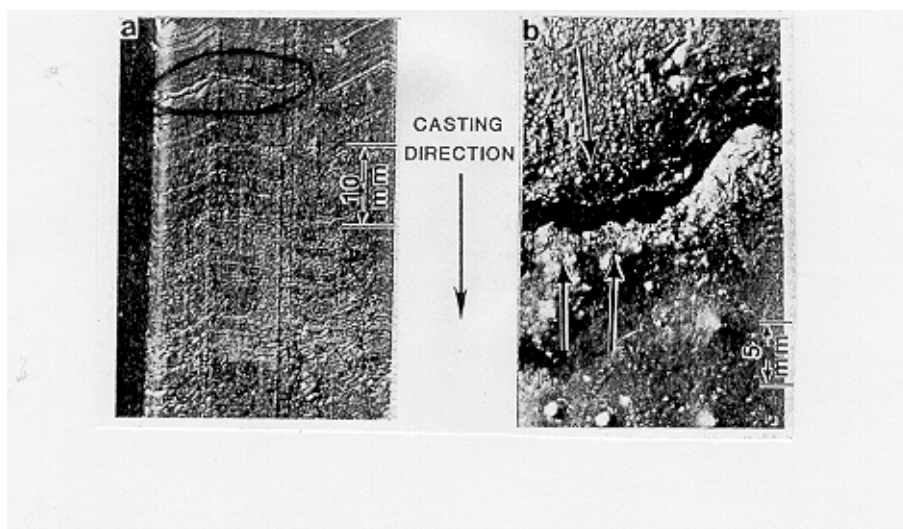


Fig. 4.2: Example of breakout propagation [31]



In this complex situation, it is practically impossible to describe the development of a breakout in the geometrical space of the mould using an analytical model based on heat transfer, solidification and the mechanical laws. The measurement and acquisition of temperature in different points at the mould surface constitute a tool for analysis and comprehension of the phenomenon. This experimental approach is also used for the development of a reliable system.

The technique is the basis of the MTM system that considers the mould as a thermal reactor and the appearance of breakout is a result of an imbalance of the distributed thermal reactions. The dynamics of process data that have generated a breakout are affected by these random terms.

#### 4.2.2 Breakout effect in the mould temperature field

Generally when a breakout is generated, the upper thermocouple records a higher temperature  $T^U$  due to the local breakout, followed by a reduction in temperature that is also due to a partial solidification (see **Figs. 4.3** and **4.4**). Under the effect of the casting speed, the crack propagates and the same phenomenon is observed at lower thermocouples  $T^L$ . Alarms and reductions of casting speed are activated. In the case of conventional techniques, when the difference between the measured temperatures and those calculated by a model reaches a fixed threshold, a series of alarms is activated. When the error reaches dangerous levels, the casting speed is automatically reduced to zero [31, 63].

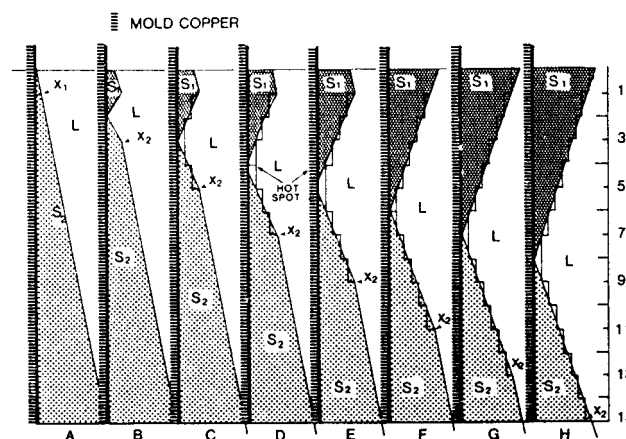


Fig. 4.3. Development of a sticking breakout [31]

**Fig. 4.4** gives an example of temperature field variation according to a breakout.

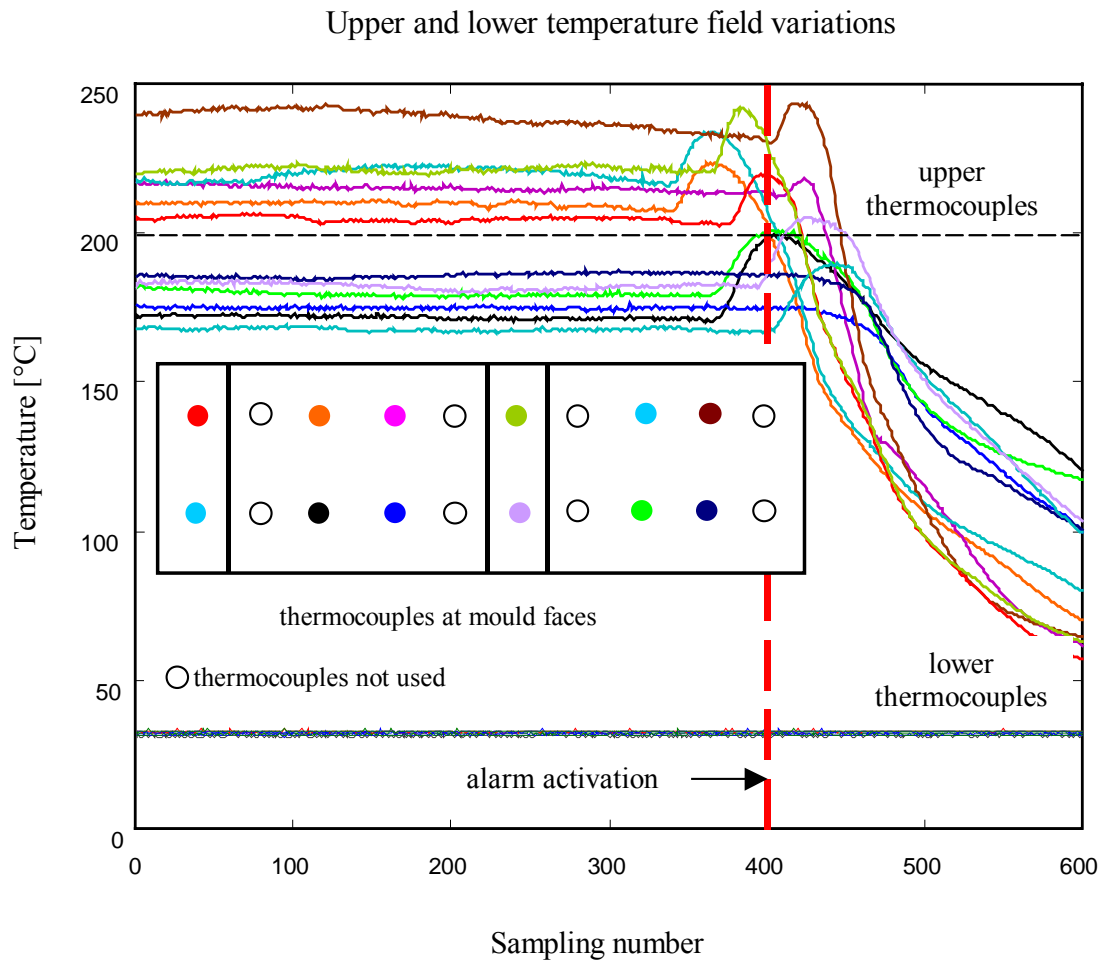


Fig. 4.4: Breakout mould temperature variations

### 4.3 Breakout prediction and detection

Since the development and implementation of the breakout detection system on continuous casting processes, efforts have been focused on the simplification of instrumentation by reducing the number of thermocouples and the development of advanced models able to minimise the number of false alarms [65]. The principle of detection is based on the analysis of temperatures on the mould and their gradients. Such a system ensures the monitoring and the detection of different alarm levels and responds to the reduction of casting speed.

Temperatures are acquired and transmitted to a computer for monitoring. Control is performed by a specific algorithm which ensures the task of detection and control. A method using the conventional or the NN model controls the analysis and the decision processes. **Fig. 4.5** gives the principle of the breakout detection system.

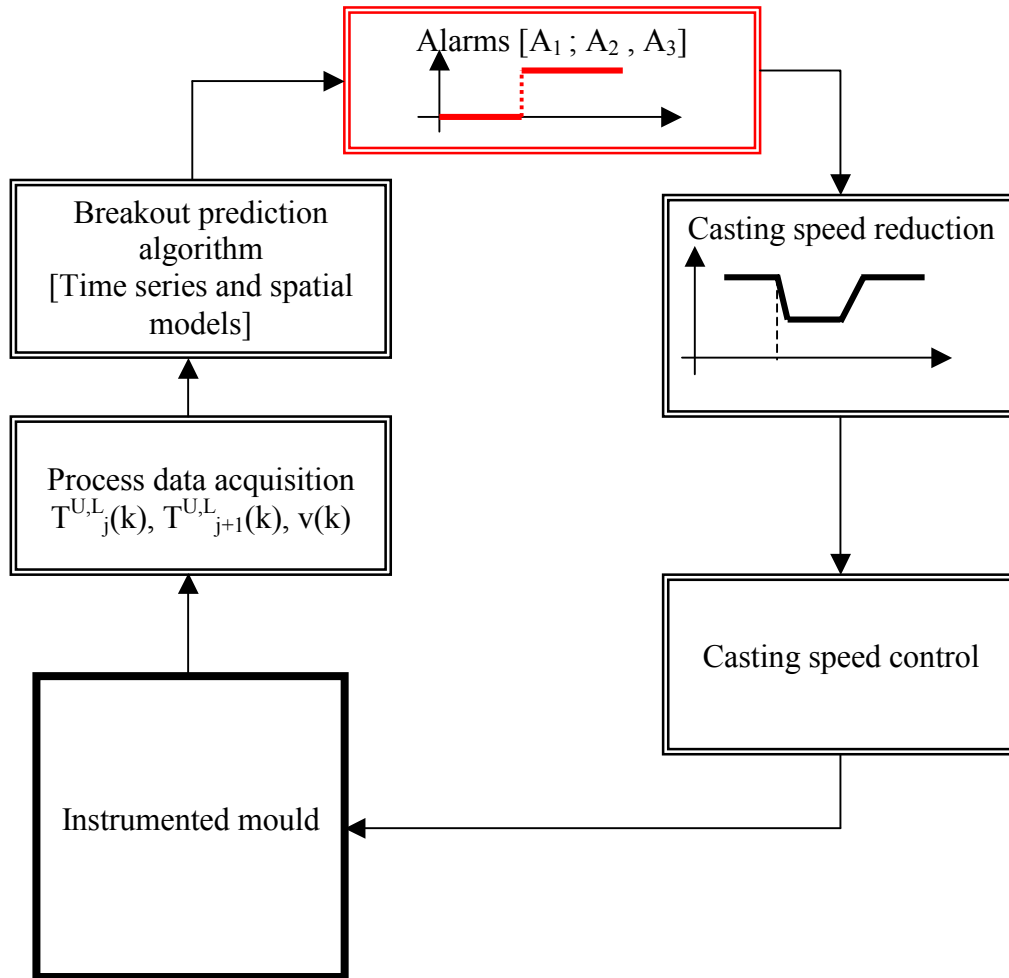


Fig. 4.5: Principle of the breakout detection system

#### 4.3.1 Mould instrumentation and measurement of thermal profiles

One of the most important parameters to be measured is the temperature of the copper on the mould surface. Generally a matrix of thermocouples is used on each mould face. **Fig. 4.6** gives the location of thermocouples on the copper plate mould. Thermocouples pair 17-18 and 19-20 correspond to the small mould faces. Thermocouples 1 to 8 and thermocouples 9 to 16 correspond to the large faces. Geometrical details of the EKO STAHL mould are presented in **Fig. 4.7**. In the case of casting using medium and small formats ( $< 1800$  mm), thermocouples 1, 2, 7, 8 and 9, 10, 15, 16 are not used.

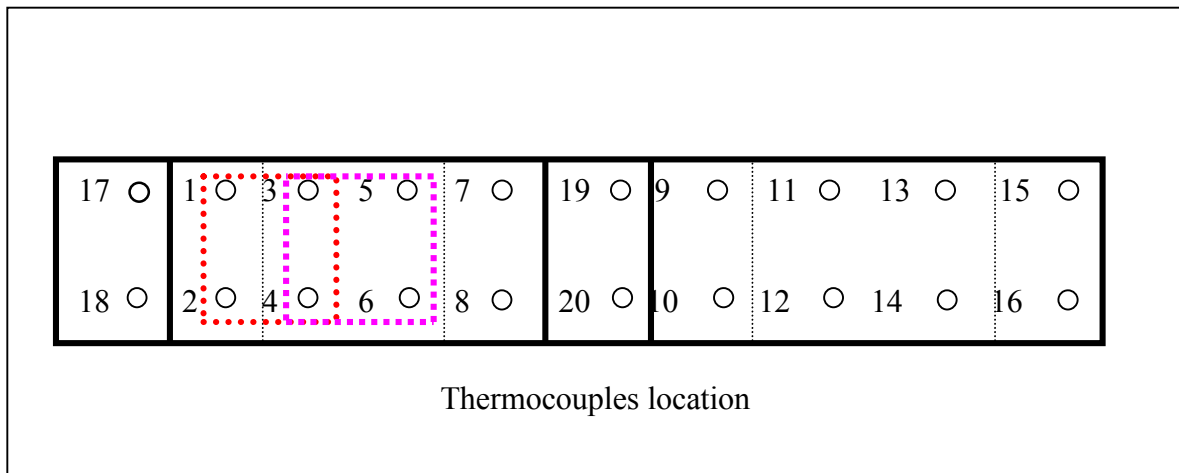


Fig. 4.6: Location of thermocouples on the copper mould faces

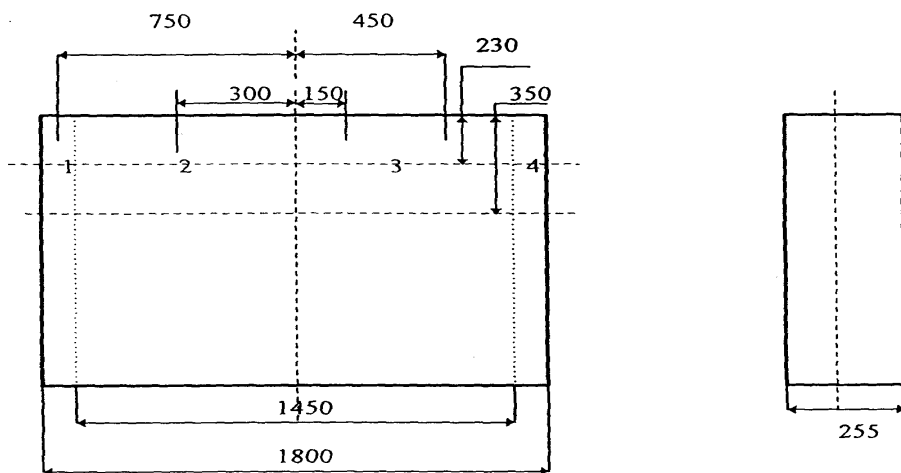


Fig. 4.7a: Geometrical details of mould faces (dimensions in mm)

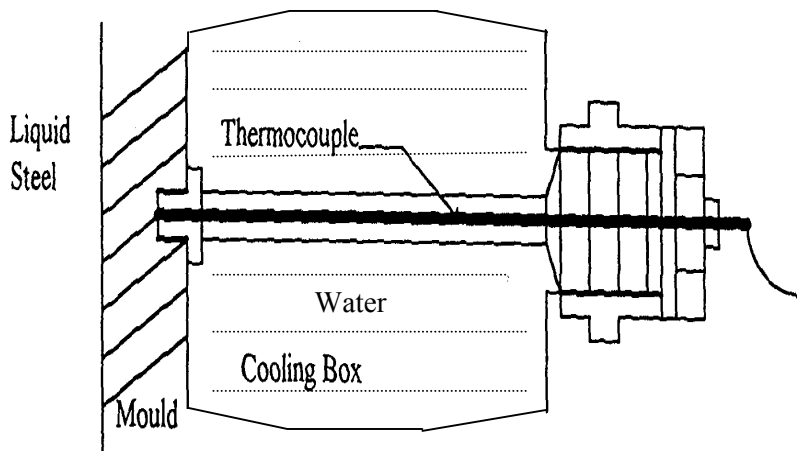


Fig. 4.7b: Principle of copper plate temperature measurement using thermocouples introduced through the cooling box

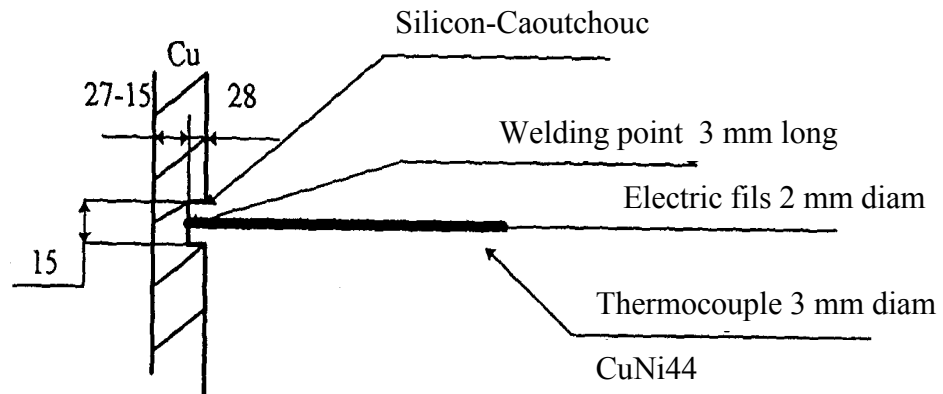


Fig. 4.7c: Principle of thermocouple fixation at the copper mould (dimensions in mm)

#### 4.3.2 Conventional method [65]

In each point  $M$  of the copper mould, the variation of temperature  $T(M,t)$  with time  $t$ , can be defined as:

$$T(M,t) = T(M,t_0) + \left[ \frac{\partial T(M,t)}{\partial t} \right]_0 \Delta t + \left[ \frac{\partial^2 T(M,t)}{\partial t^2} \right]_0 \Delta t^2 + \dots + \left[ \frac{\partial^n T(M,t)}{\partial t^n} \right]_0 \Delta t^n + \Delta T(0) \quad (4.1)$$

The conventional approach approximates the temperature dynamics as a linear function of time:

$$T(M,t) = T(M,t_0) + \left[ \frac{\partial T(M,t)}{\partial t} \right]_0 \Delta t \quad (4.2)$$

$$= T(M,t_0) + a \cdot \Delta t \quad (4.3)$$

**Fig. 4.8** gives a geometrical interpretation of temperature dynamics

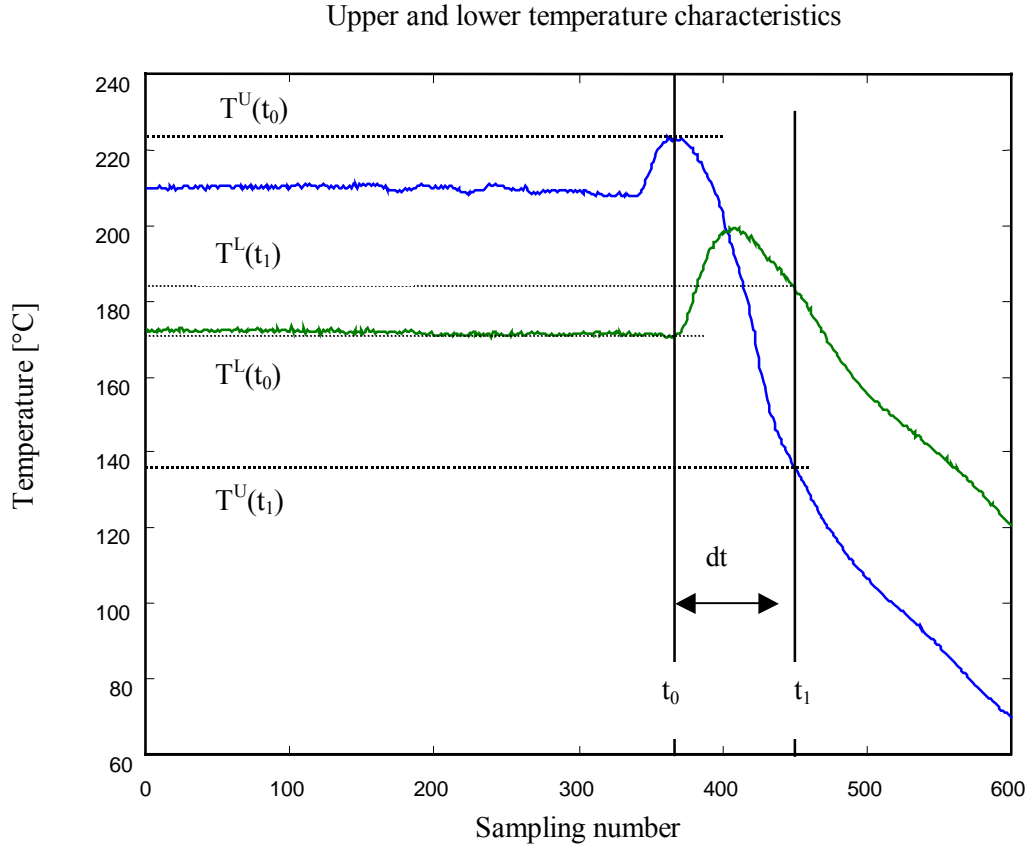


Fig. 4.8: Geometrical interpretation of a breakout

Three cases of temperature dynamics are taken into account by the conventional system:

The gradients of upper and lower temperature are defined as:

$$a^U = \left[ \frac{\partial T^U(t)}{\partial t} \right]_0 = \frac{T^U(t_0) - T^U(t_1)}{t_1 - t_0} \quad (4.4)$$

$$a^L = \left[ \frac{\partial T^L(t)}{\partial t} \right]_0 = \frac{T^L(t_0) - T^L(t_1)}{t_1 - t_0} \quad (4.5)$$

The temperature difference between the upper and the lower thermocouples is expressed as:

$$\Delta T(t_1)^{U-L} = T^U(t_1) - T^L(t_1) \quad (4.6)$$

The breakout detection algorithm is based on the analysis of the values of equations (4.4), (4.5) and (4.6). The limits of  $a^U$ ,  $a^L$  and  $\Delta T^{U-L}$  are predefined [65].

False alarms are generally due to thermal perturbations. Sometimes these variations cannot be well detected by the conventional system using a fixed error range or a predefined statistical characteristics of the error between measured and calculated temperatures in each point. This introduces some false alarms and reduces the process reliability. The neural network permits

to solve the problem by the learning process using the breakout data base related to the real and false alarm situation, respectively.

### 4.3.3 Advanced methods using neural network modelling

The principle of breakout detection using neural networks is based on the analysis of a node of thermocouples regarding upper and lower processing units. Each unit considers the temperature variation in time (time series model) and the interaction between different thermocouple temperatures (spatial model). **Fig. 4.9** gives the principle of the neural network breakout detection system.

#### 4.3.3.1 Upper processing unit

##### 4.3.3.1.1 Time series model

The time series model takes into account the temperature variations that can be approximated by equation (4.1). The principle is to find the whole complex of relations between dynamic variations of temperature and the appearance of defects [63, 69, 113]. This can be formulated by the following non-linear relationship:

$$Alarm = NN[\Delta T(k), \Delta T(k-1) \dots \Delta T(k-n)] \quad (4.7)$$

$\Delta T(k)$  is the temperature change which is defined as:

$$\Delta T(k) = T(k) - T(k-1) \quad (4.8)$$

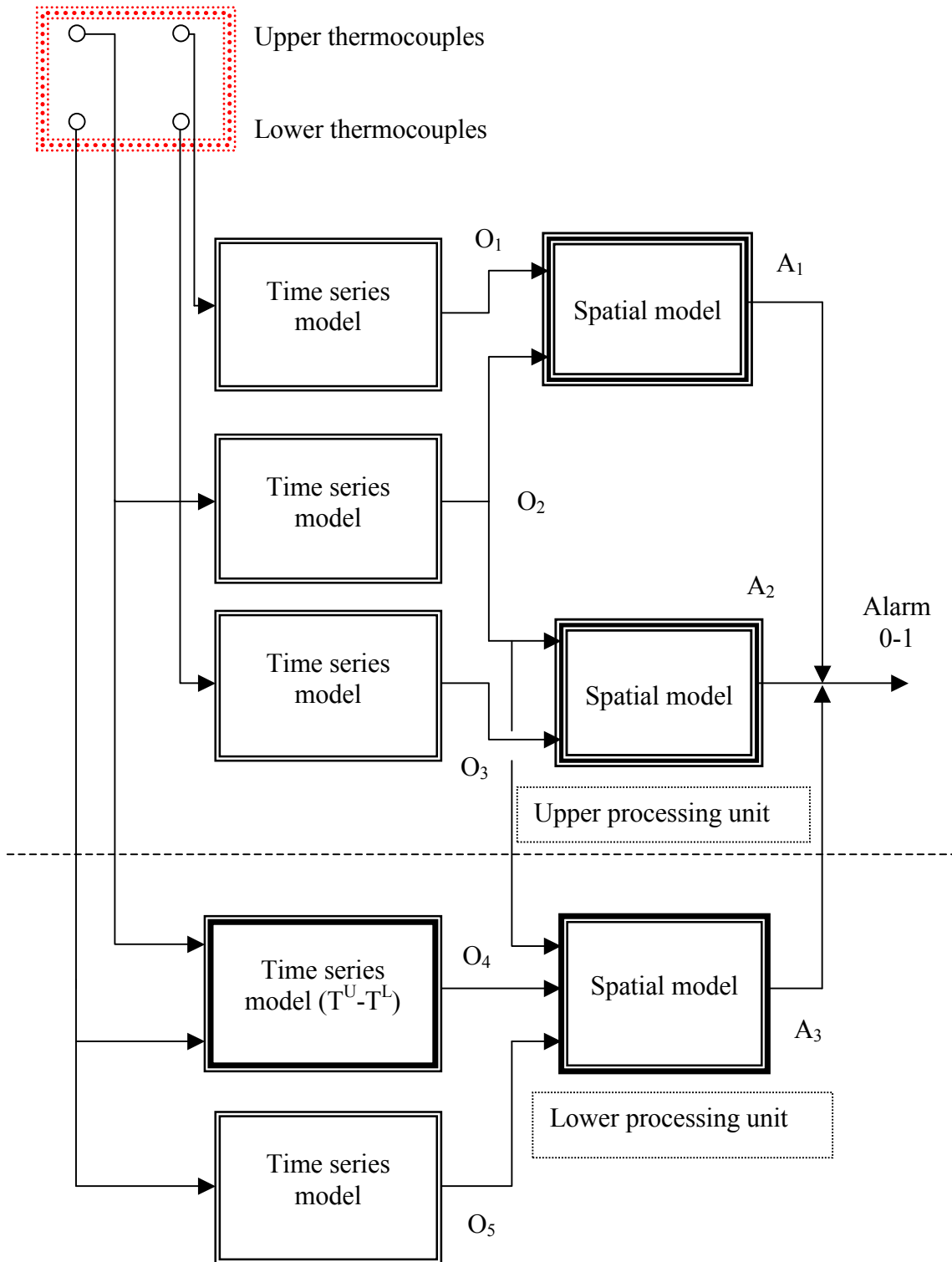


Fig. 4.9: Principle of breakout detection using the NN model



The model is obtained by the learning process using the back-propagation algorithm and the characteristics of breakout temperature. **Fig. 4.10** gives the learning principle of the time series model.

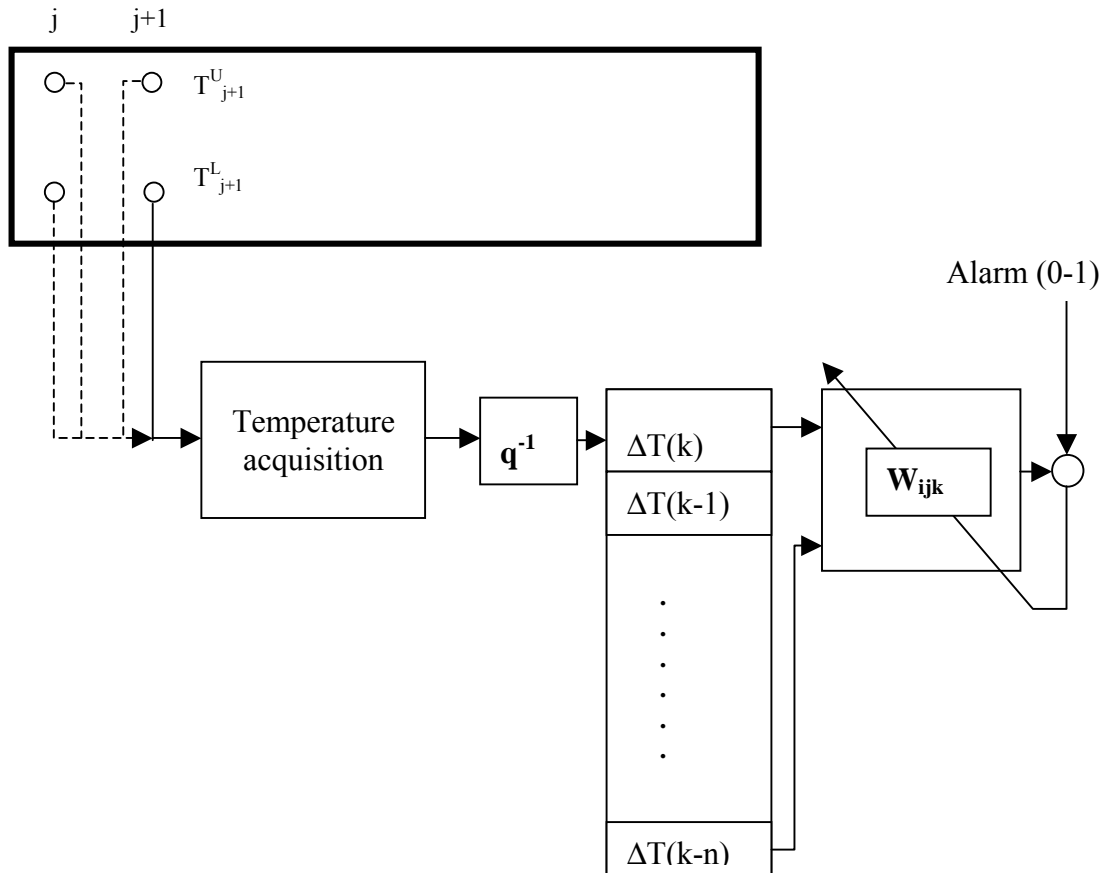


Fig. 4.10: Principle of learning process

After several trials an optimal neural network with ( $n=60$ ) in the input layer, 15 nodes in the first layer and one node in the output layer that corresponds to the alarm output signal has been chosen.

After the convergence, network weights  $W_{ijk}$  are collected in a file for further use with regard to other thermal profile breakout detections.

**Fig. 4.11** shows the learning process using a thermal profile corresponding to a real breakout from EKO STAHL. Breakouts are detected by a conventional system at the sampling number 400. Alarm is released by passing from 0 to 1.

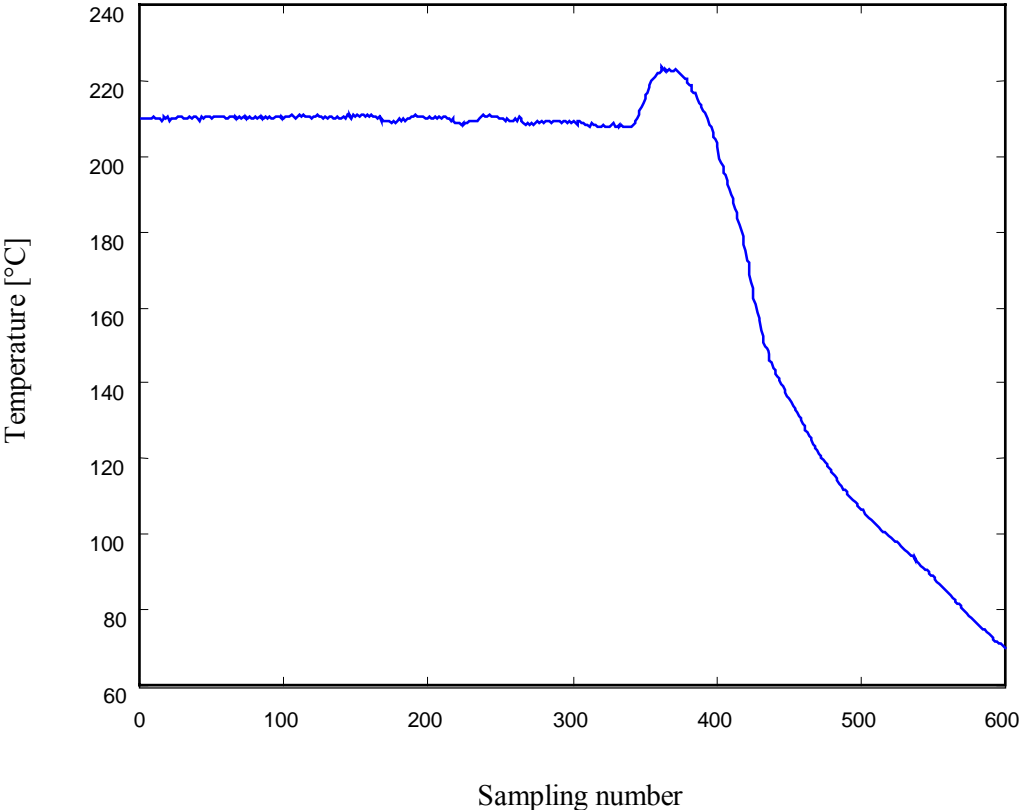


Fig. 4.11a: Example of breakout thermal profile variations

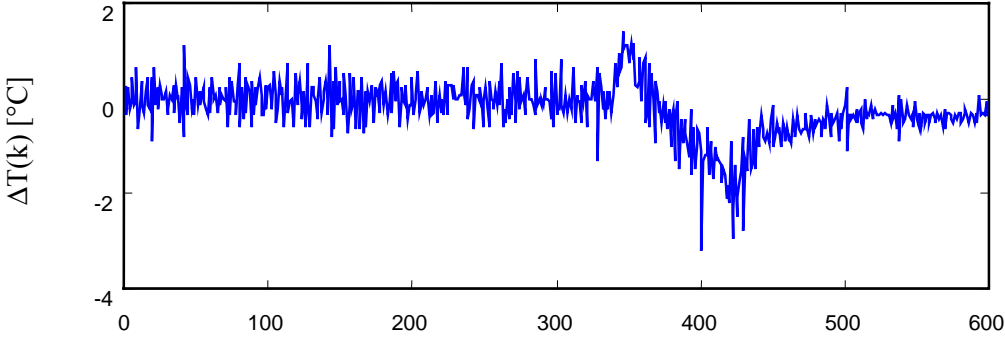


Fig. 4.11b: Differentiation of equ(4.8)

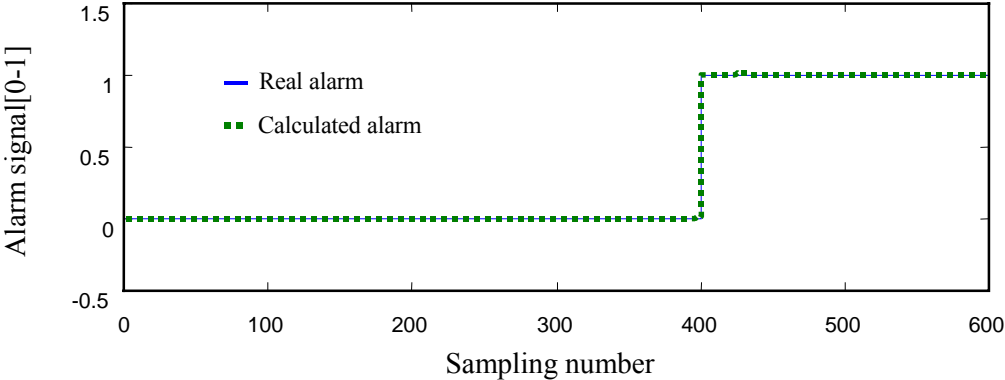


Fig. 4.11c: Calculated and real alarms

### 4.3.3.1.2 Spatial model

The Spatial Model assumes cross interaction between the thermocouples upper(j)-upper(j+1) and upper(j)-lower(j+1).

$O_1$  is the alarm output corresponding to the time series model of the upper thermocouple (j+1)

$O_2$  is the alarm output corresponding to the time series model of the upper thermocouple (j)

$O_3$  is the alarm output corresponding to the time series model of the lower thermocouple (j+1)

**Fig. 4.12** gives the principle of final alarm signals, **Fig. 4.12a** the structure of the spatial model and **Fig. 4.12b** the architecture of the NNs.

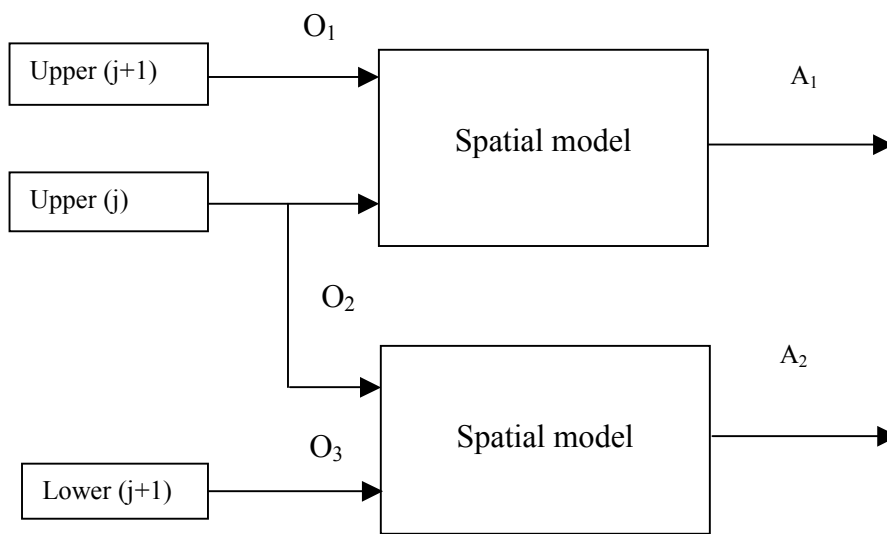


Fig. 4.12a: Structure of the spatial model

$$A_1 = NN_s(O_1, O_2) \quad (4.9)$$

$$A_2 = NN_s(O_2, O_3) \quad (4.10)$$

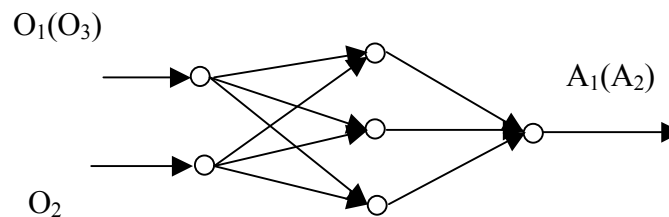


Fig. 4.12b: Architecture of the NNs

**Table 4.1** gives the logic table of the spatial model according to the lower processing unit.

O <sub>1</sub>	O <sub>2</sub>	A <sub>1</sub>	O <sub>2</sub>	O <sub>3</sub>	A <sub>2</sub>
0	0	0	0	0	0
0	1	0	0	1	0
1	1	1	1	1	1
1	0	0	1	0	0

Table. 4.1: Logic table of spatial model (upper processing unit)

#### 4.3.3.2 Lower processing unit

Lower processing units assume a breakout control using the time series model related to the temperature difference between the upper and lower thermocouples. They are also considered as a spatial model to analyse the cross interaction between lower and upper thermocouples.

##### 4.3.3.2.1 Time series model

For lower processing units the temperature difference between the upper and the lower thermocouples is considered.

$$\Delta T^{U-L}(k) = T^U(k) - T^L(k) \quad (4.11).$$

In the same manner as in section (4.3.3.1.1) the output alarm is calculated as:

$$Alarm = NN[\Delta T^{U-L}(k)] \quad (4.12)$$

**Fig. 4.13** illustrates the learning process using the difference  $\Delta T^{U-L}(k)$  between the upper and lower thermocouples using breakout data from EKO STAHL. Breakouts are detected by a conventional system. At the sampling number of 400, alarm is activated by passing from 0 to 1.

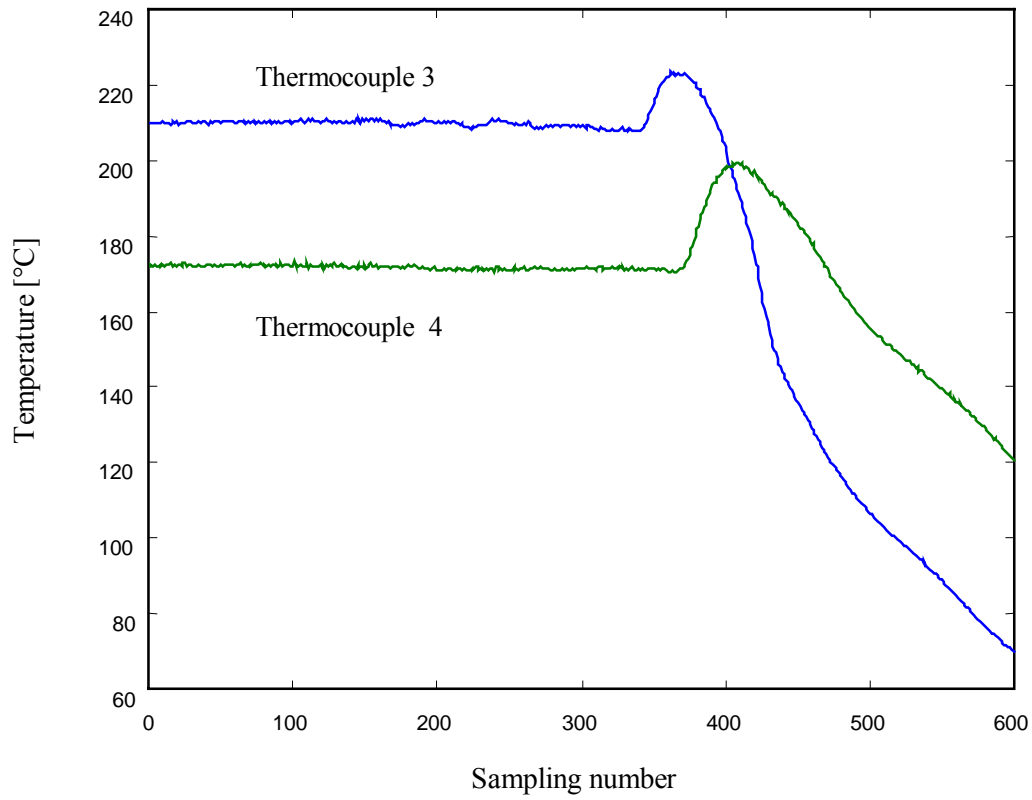


Fig. 4.13a: Upper and lower temperature variations

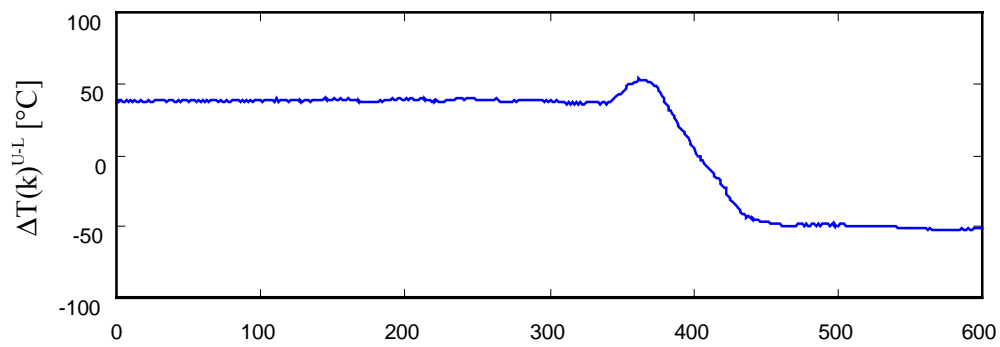
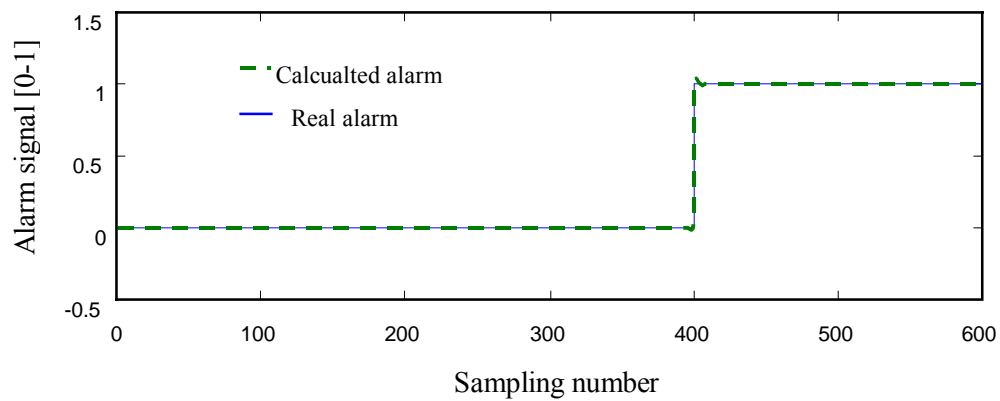
Fig. 4.13b: Difference  $\Delta T(k)^{U-L}[3-4]$ 

Fig. 4.13c: Calculated and real alarms

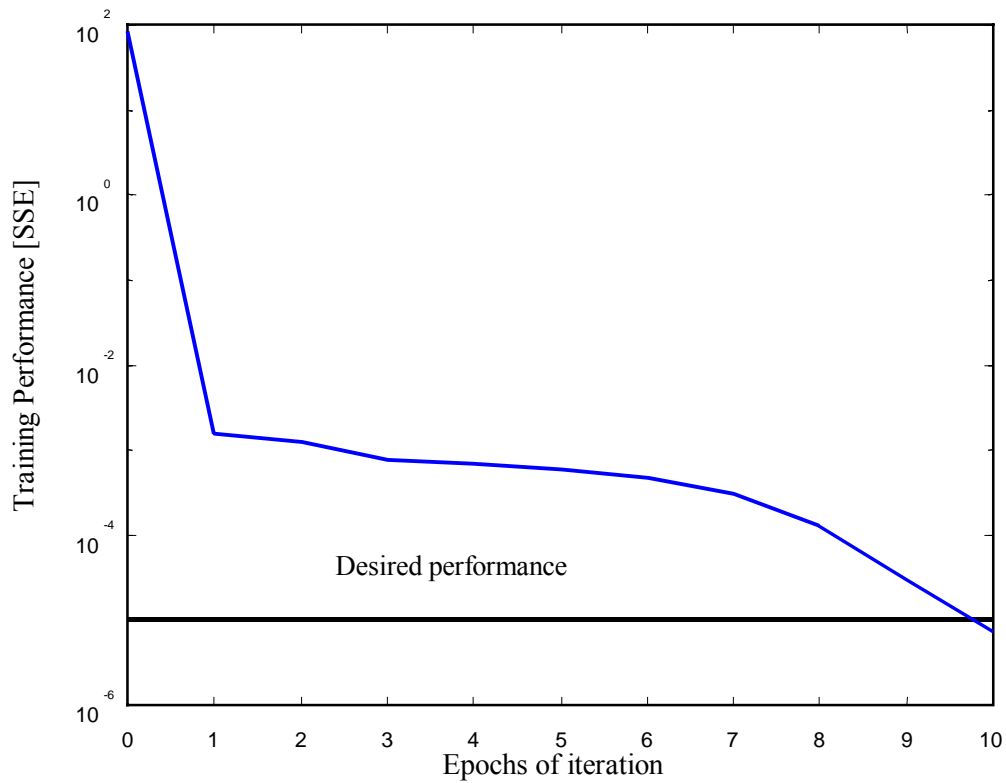


Fig. 4.13d: Learning convergence

#### 4.3.3.2.2 Spatial model

$O_4$  is the alarm output corresponding to the time series model according to the temperature difference between the upper(j) and lower(j) thermocouples.

$O_5$  is the alarm output corresponding to the time series model of the lower thermocouple (j+1)

The principle of final alarm is given by the following scheme (**Fig. 4.14a**):

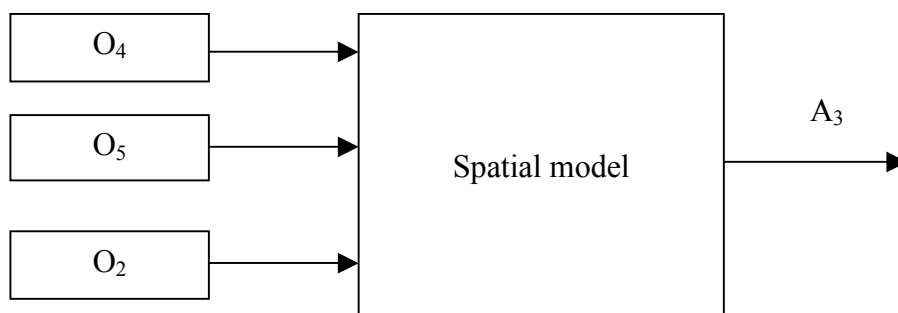


Fig. 4.14a: Spatial model (lower processing unit)

$$A_3 = NN_s^L(O_2, O_4, O_5) \quad (4.13)$$

The  $NN_s^L$  architecture is given in **Fig. 4.14b**.

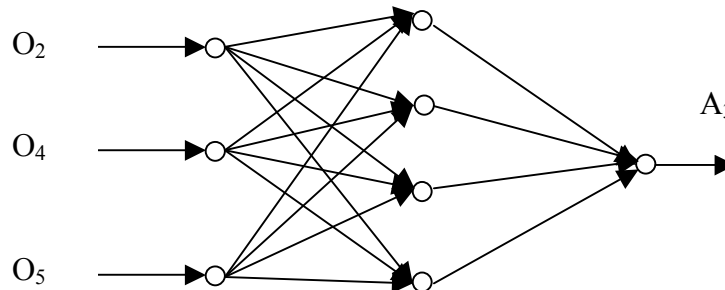


Fig. 4.14b: Architecture of  $NN_s^L$

**Table 4.2** gives the logic table of the spatial model according to the lower processing unit.

$O_2$	$O_4$	$O_5$	$A_3$
0	0	0	0
0	0	1	0
0	1	1	1
1	1	1	1
1	0	1	0
1	0	0	0
1	1	0	1
0	1	0	0

Table. 4.2: Logic table of spatial model (lower processing unit)

$NN_s^L$  is a combination of AND and OR logical function, it can be defined as:

$$A_3 = [(O_2 \text{ OR } O_5) \text{ AND } O_4] \quad (4.14)$$

#### 4.3.4 Application

Using a typical breakout (alarm and temperature variations) detected by the conventional system from EKO STAHL, a NN model has been developed in section (4.3.3). The obtained NN models will be used to predict new series of alarm breakouts based on measured temperature fields.

The principle given in **Fig. 4.15** consists of comparing the ability of the developed model to detect alarms with the conventional system and reality.

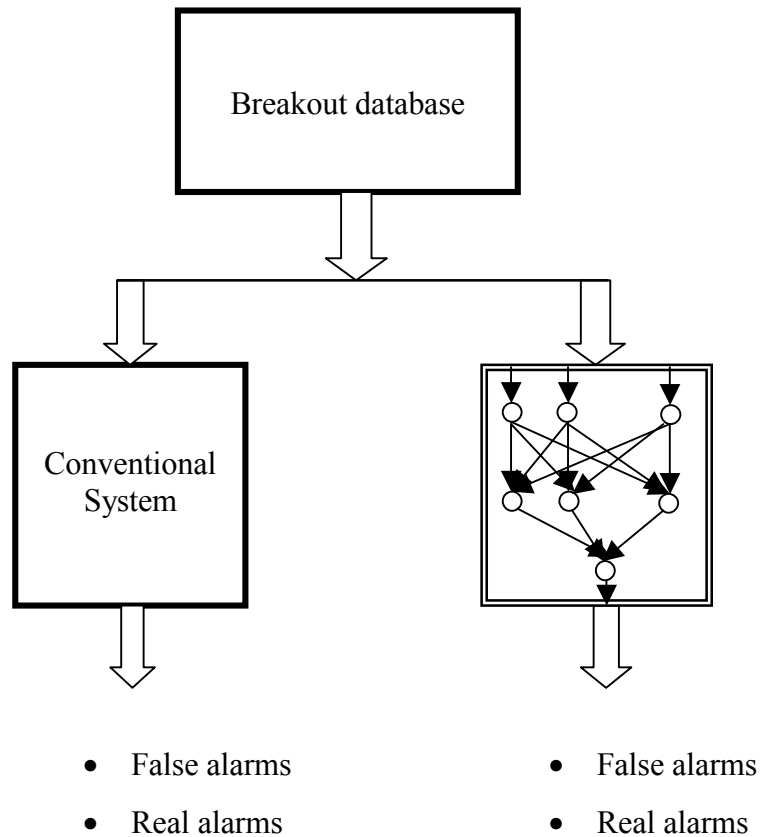


Fig. 4.15: Comparison of detection abilities of conventional and NN models

#### 4.3.4.1 Application to real breakout prediction

In the following figures, the real alarms detected by the conventional system at a sampling number of 400 is given. The NN model ability to predict real alarms will be tested through these series of breakouts. Ten real breakouts have been considered. Each figure contains the measured temperature variations around the sticking point, the data processing such as  $\Delta T(k)$  and alarm outputs according to upper and lower processing units. Results are given in **Figs. 4.16, 4.17, 4.18** and **4.19**.



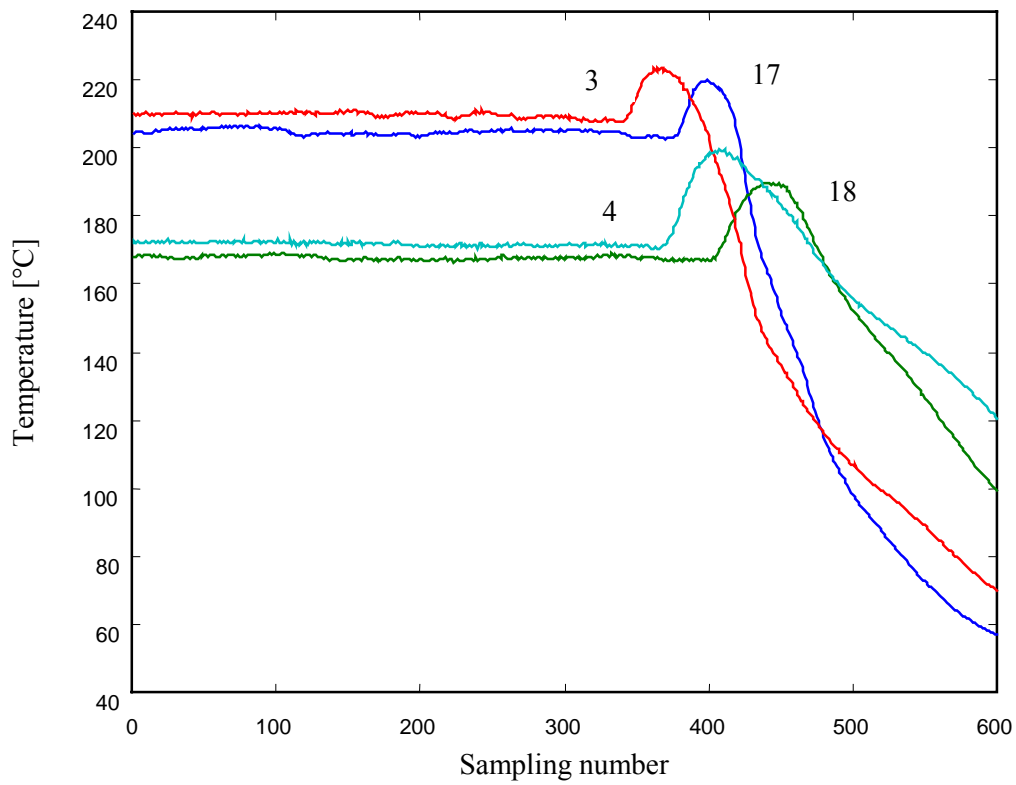


Fig. 4.16a: Real breakout Nr 1: Thermocouple node [17-3-18-4]

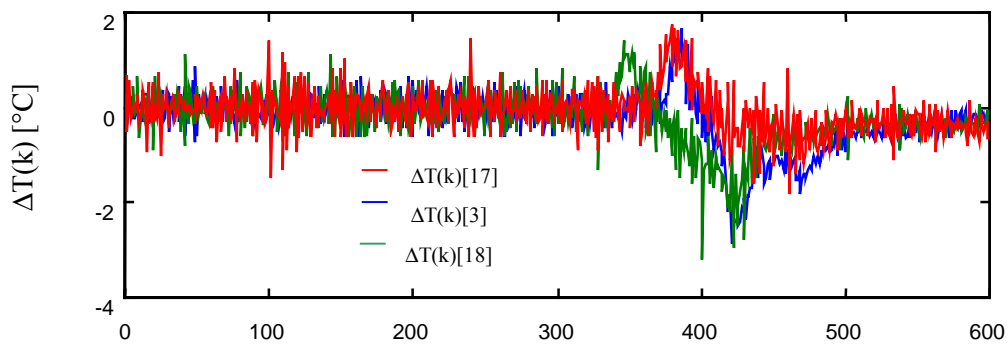


Fig. 4.16b: Differentiation of equ(4.8)

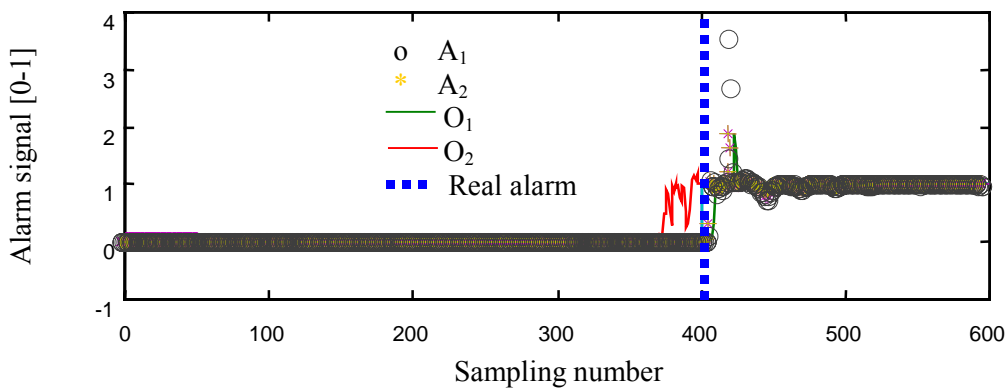


Fig. 4.16c: Calculated and real alarms

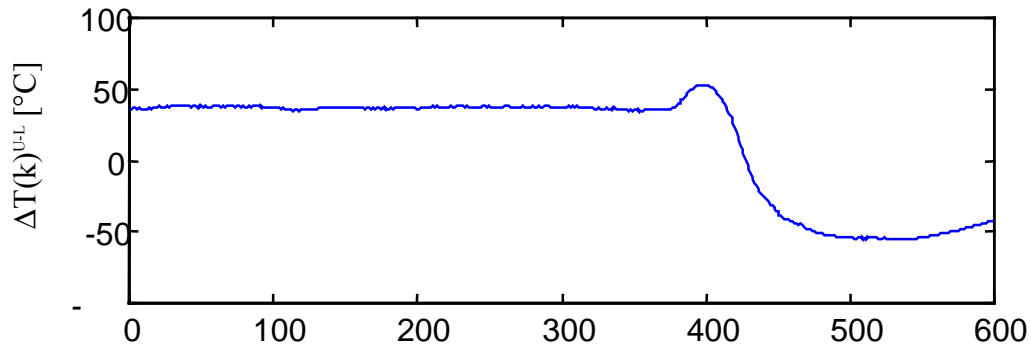


Fig. 4.16d: Difference  $\Delta T(k)^{U-L}$  [17-18]

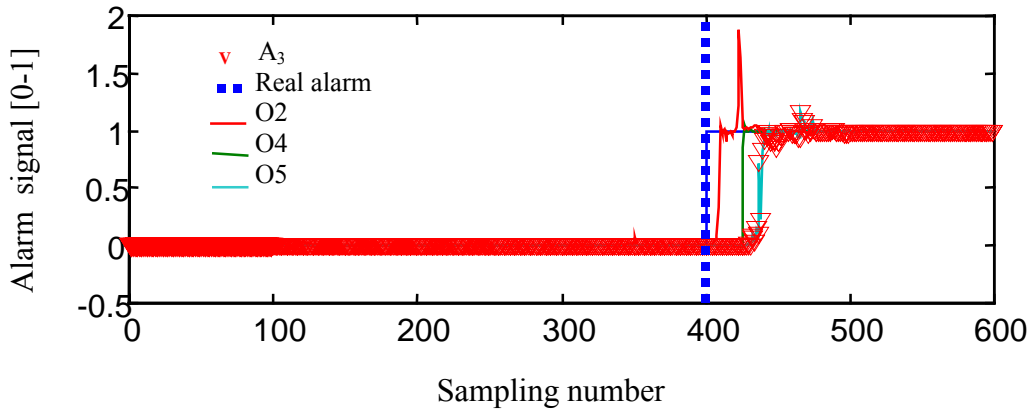


Fig. 4.16e: Calculated and real alarms

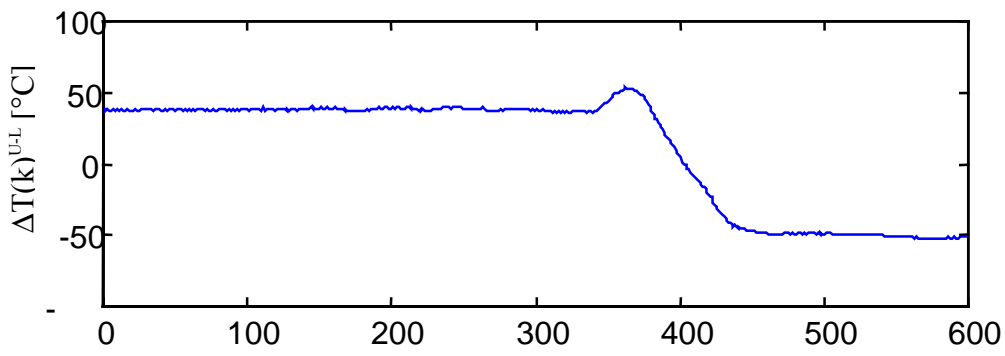


Fig. 4.16f: Difference  $\Delta T(k)^{U-L}$  [3-4]

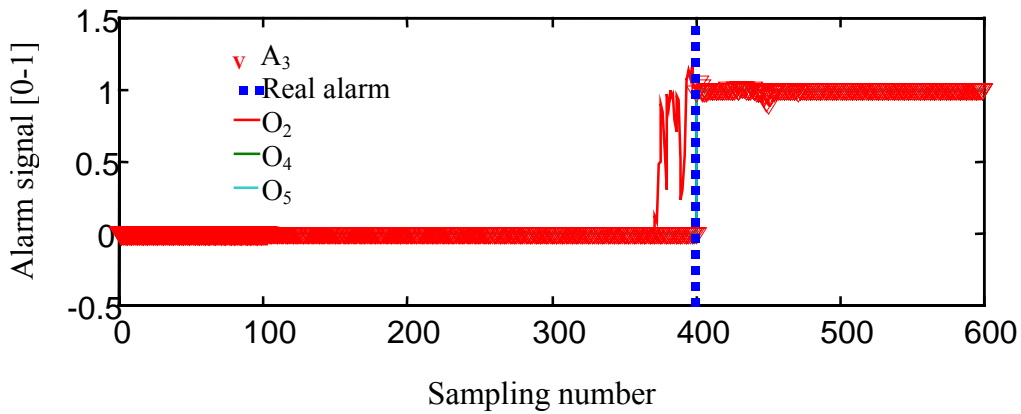


Fig. 4.16g: Real and calculated alarms

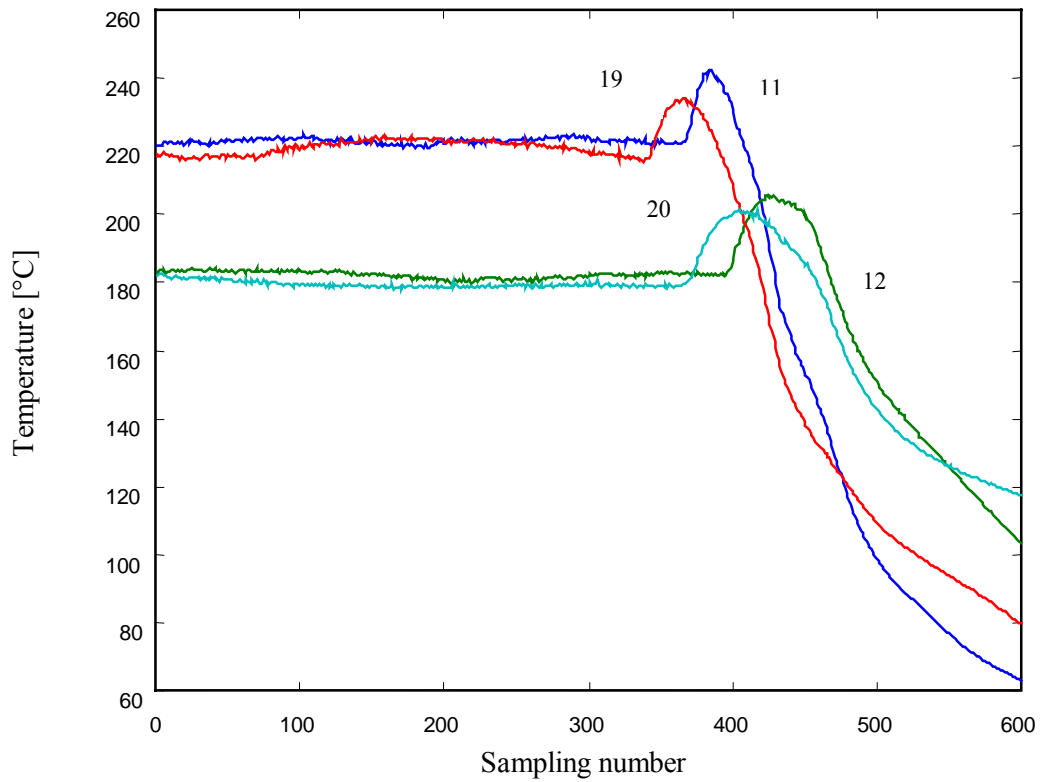


Fig. 4.17a: Real breakout Nr 1: Thermocouple node [19-20-11-12]

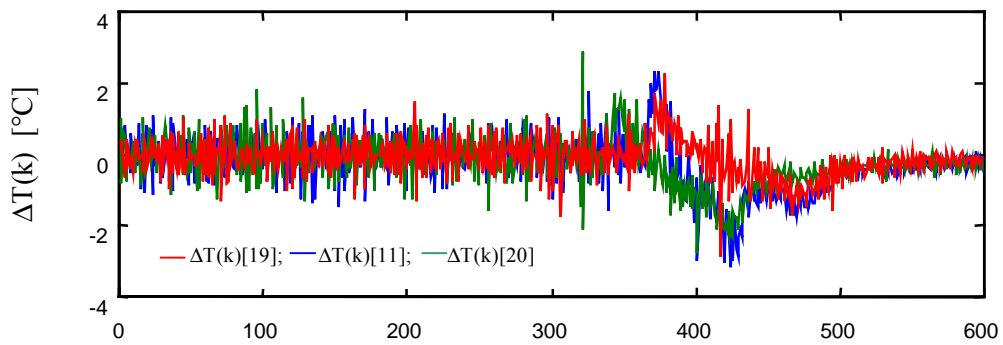


Fig. 4.17b: Differentiation of equ(4.8)

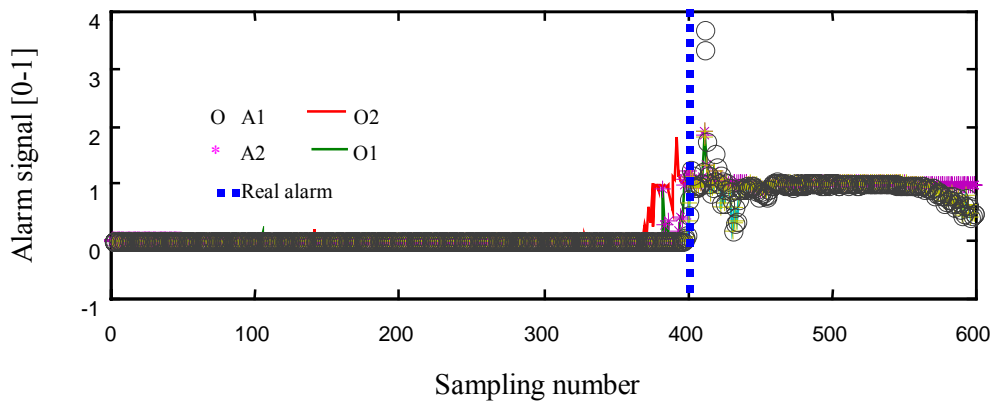


Fig. 4.17c: Calculated and real alarms

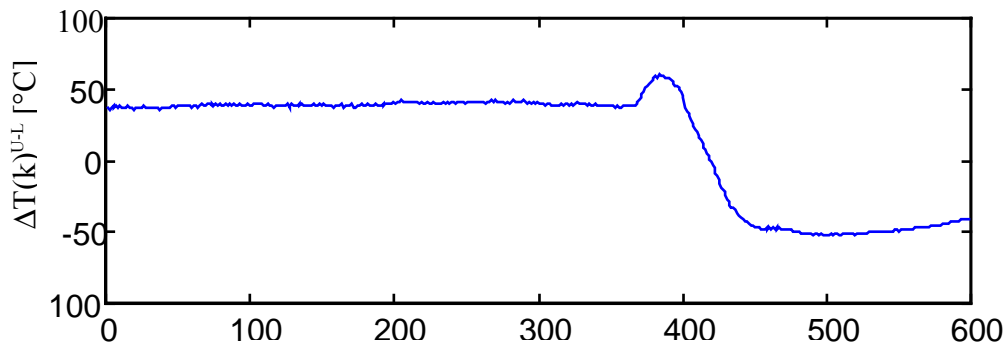


Fig. 4.17d: Difference  $\Delta T(k)^{U-L}$  [19-20]

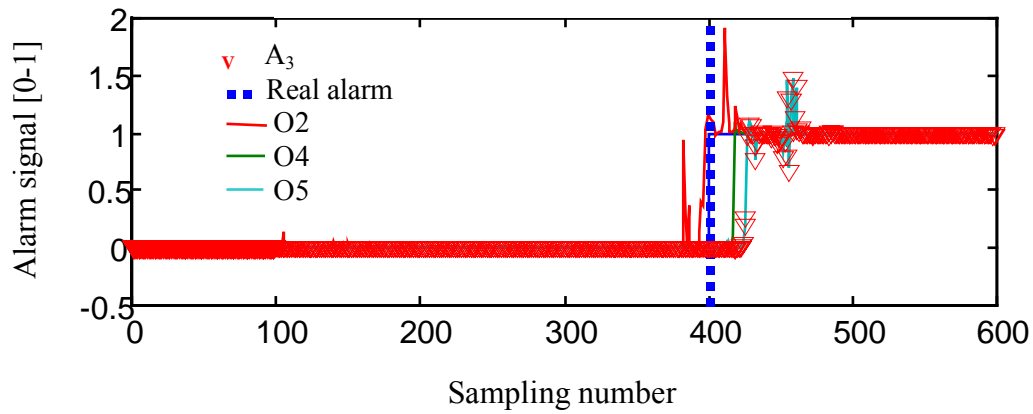


Fig. 4.17e: Real and calculated alarms

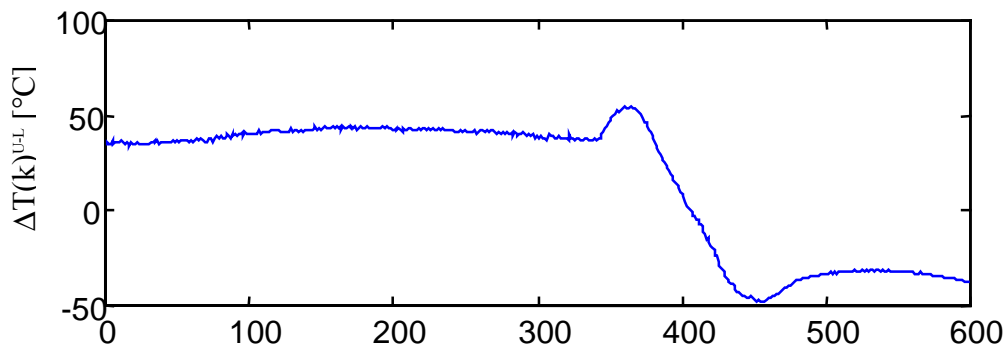


Fig. 4.17f: Difference  $\Delta T(k)^{U-L}$  [11-12]

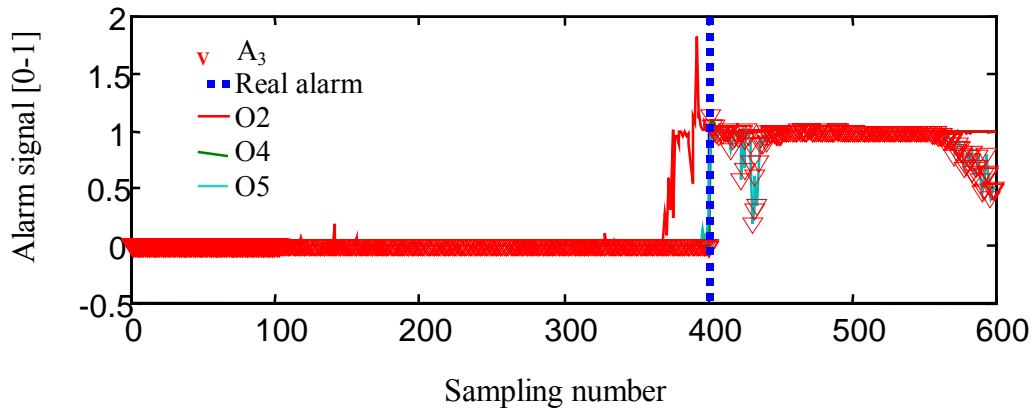


Fig. 4.17g: Real and calculated alarms

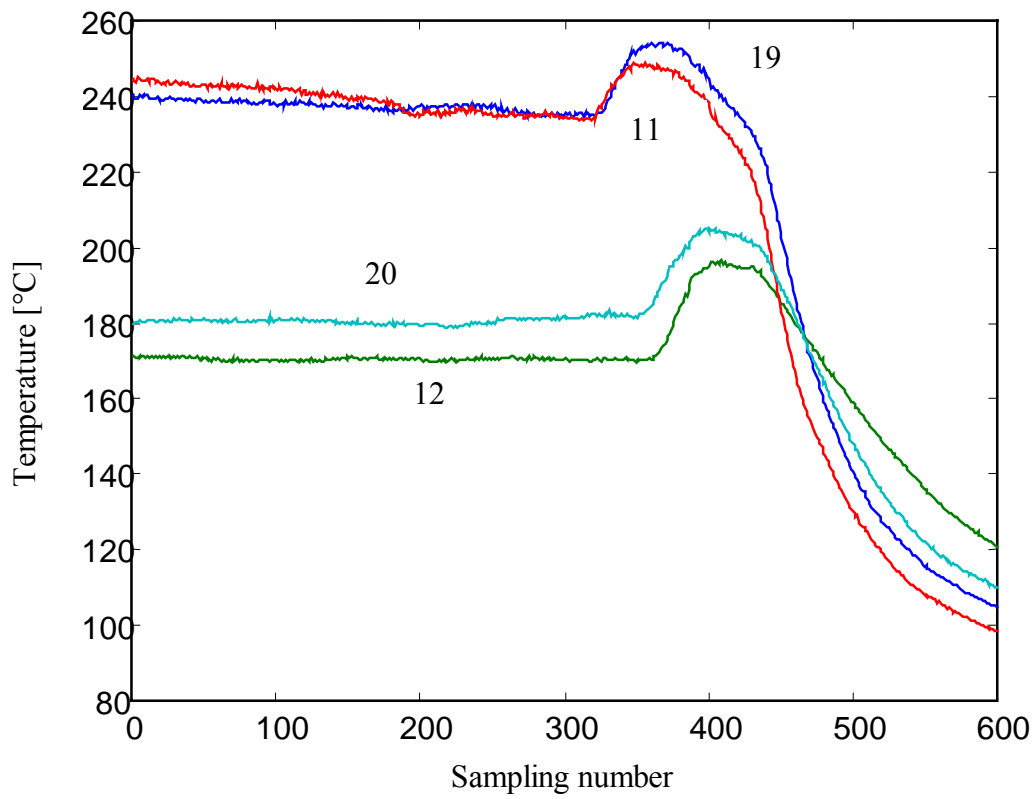


Fig. 4.18a: Real breakout Nr 2: Thermocouple node [19-20-11-12]

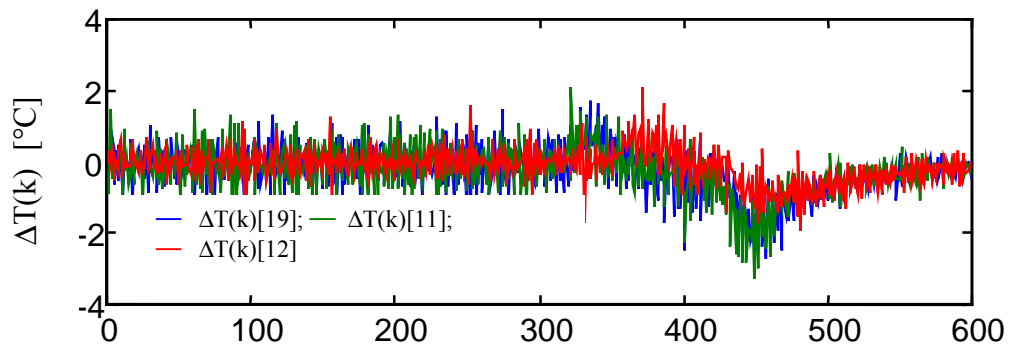


Fig. 4.18b: Differentiation of equ(4.8)

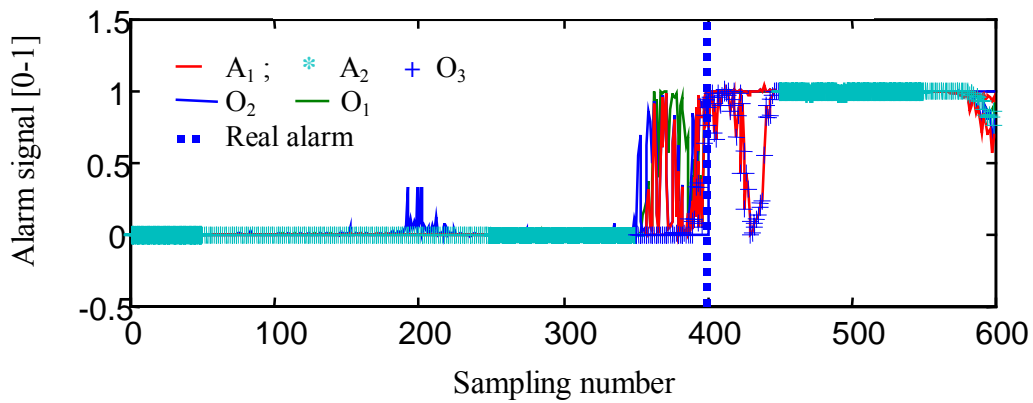


Fig. 4.18c: Calculated and real alarms

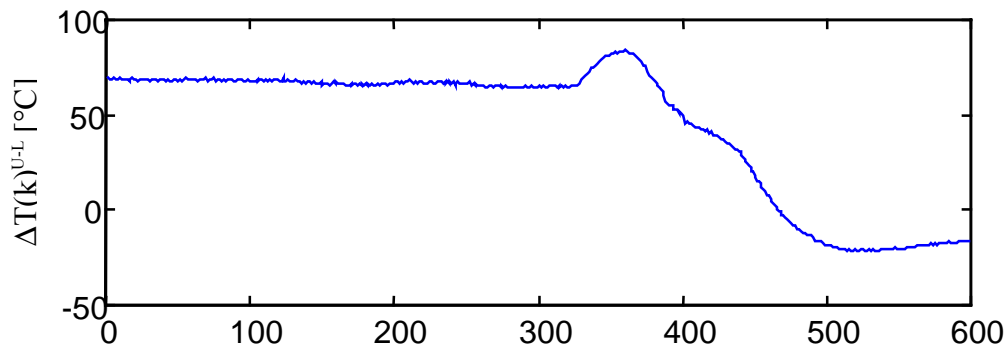
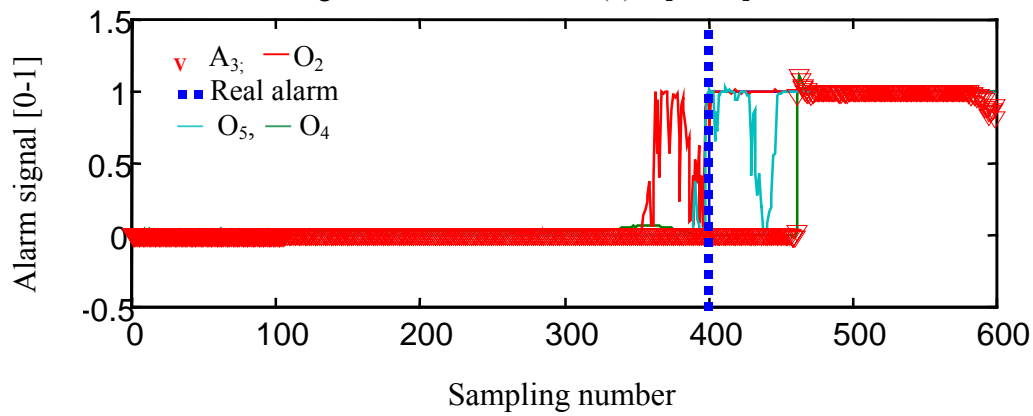
Fig. 4.18d: Difference  $\Delta T(k)^{U-L}$  [11-12]

Fig. 4.18e: Real and calculated alarms

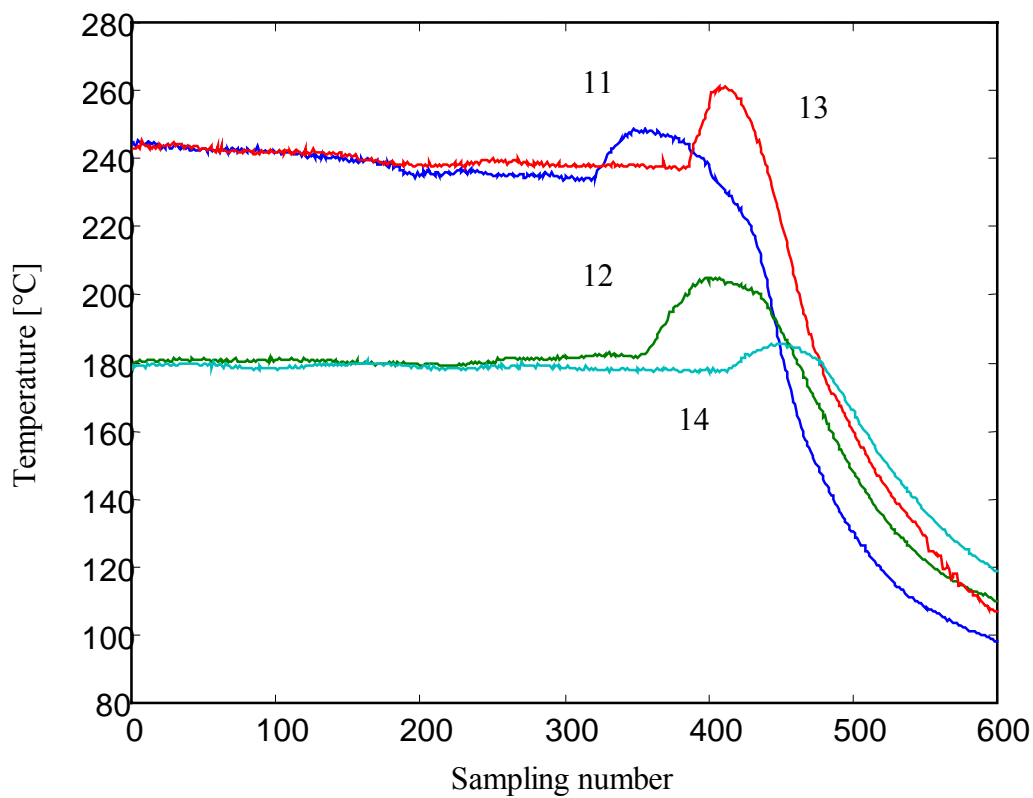


Fig. 4.19a: Real breakout Nr 2: Thermocouples node [13-11-12-14]

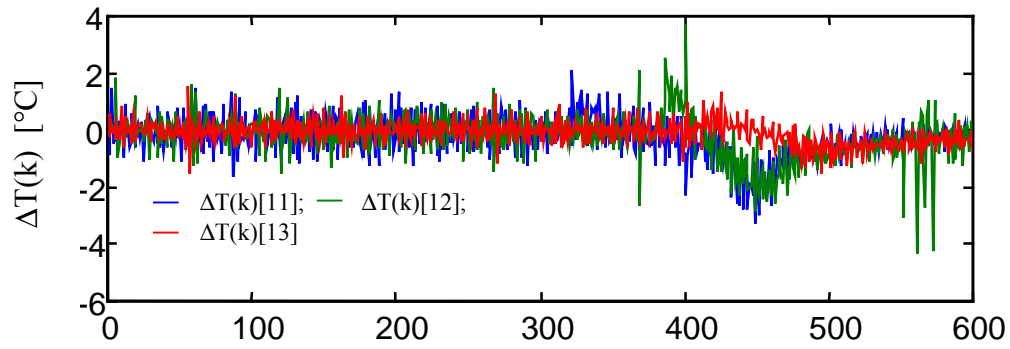


Fig. 4.19b: Differentiation of equ(4.8)

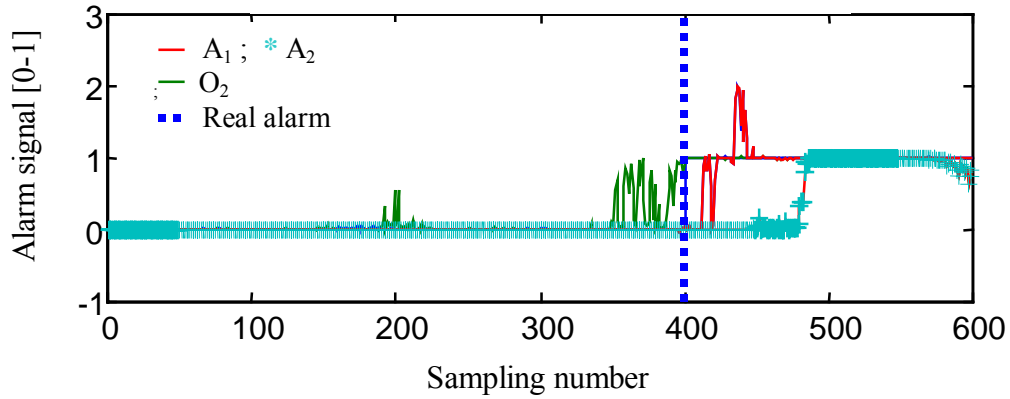


Fig. 4.19c: Calculated and real alarms

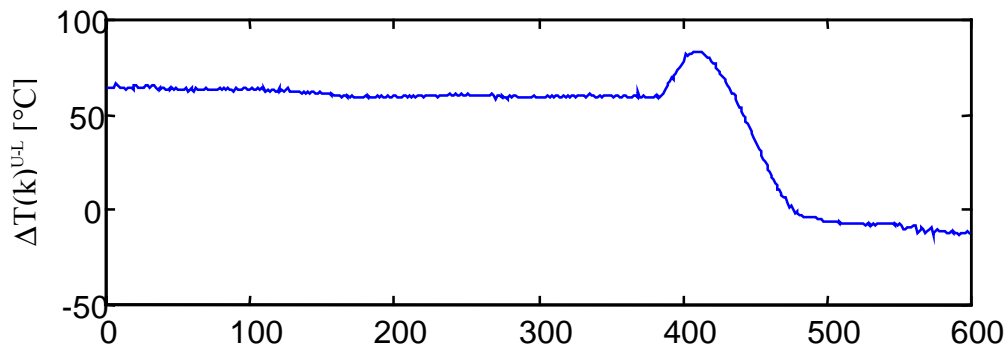


Fig. 4.19d: Difference  $\Delta T(k)^{U-L}[13-14]$

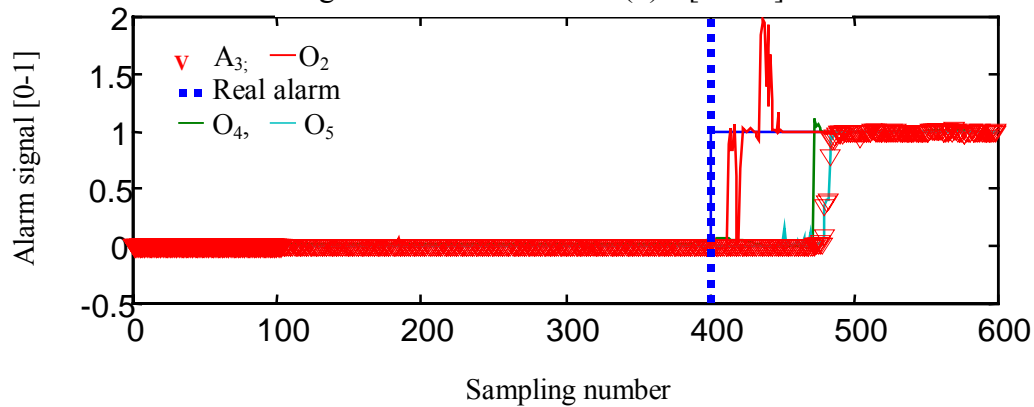
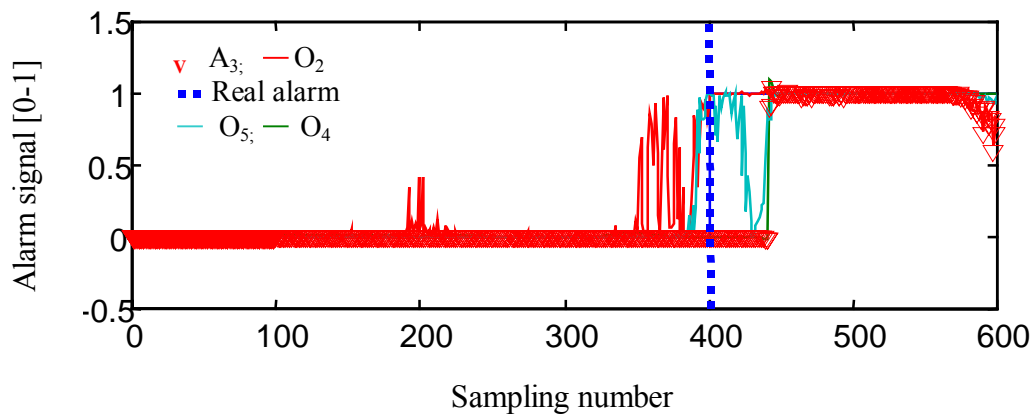
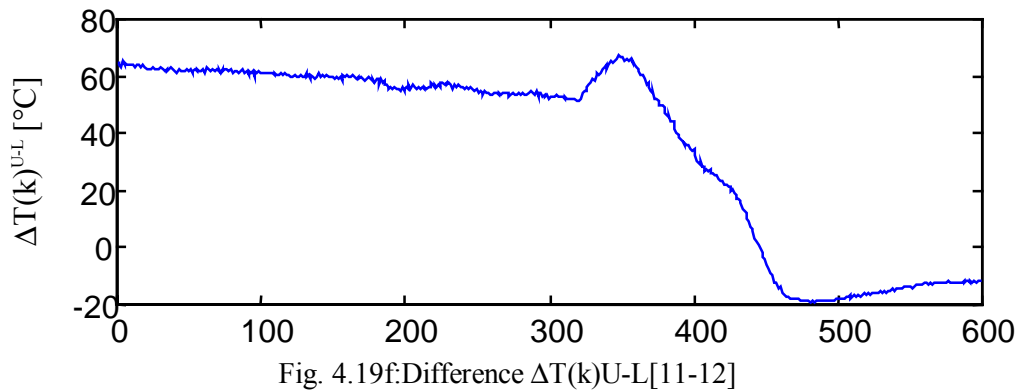


Fig. 4.19e: Real and calculated alarms



#### 4.3.4.2 Application to false breakout prediction

In this section false alarm processing detected by the conventional system at a sampling number of 400 is considered. False alarm is an alarm detected by the system while there is no breakout in reality. False alarm is generally announced by the conventional system when there are some measured temperature variations without generation of a real breakout. This situation can be observed at the moment of slag incrustation or measured temperature fluctuations.

This work considered four (4) false alarms detected by the conventional system from EKO STAHL. Results are given in **Figs. 4.20, 4.21 and 4.22.**



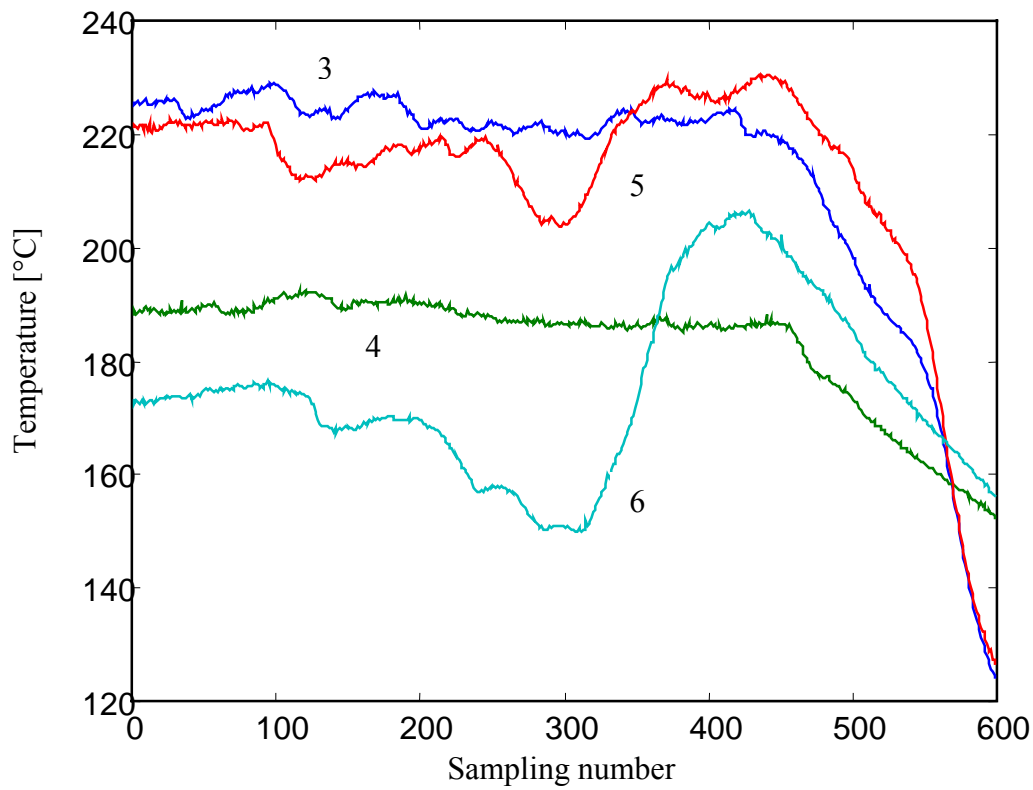


Fig. 4.20a: False breakout Nr 1: Thermocouple node [3-4-5-6]

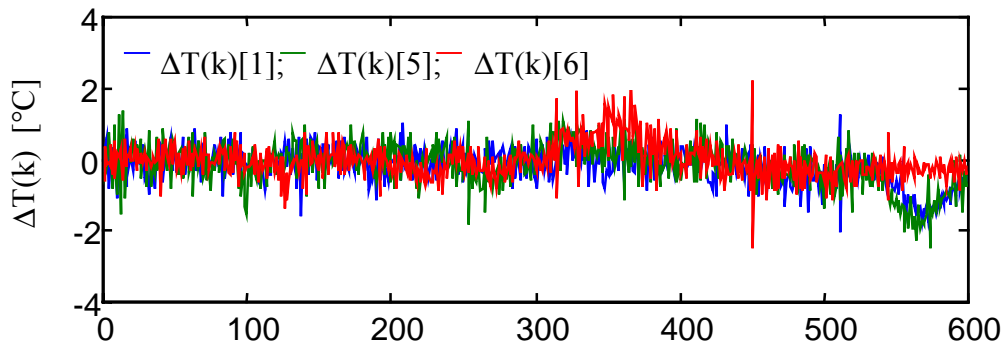


Fig. 4.20b: Differentiation of equ(4.8)

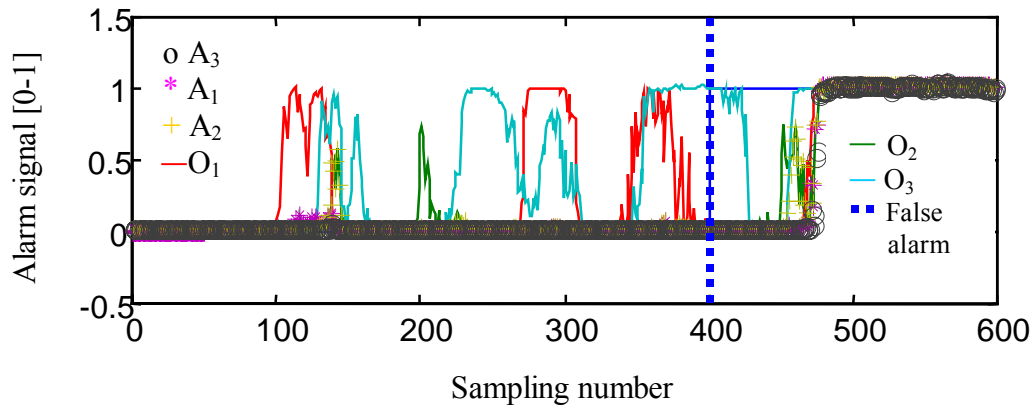


Fig. 4.20c: Real and calculated alarms

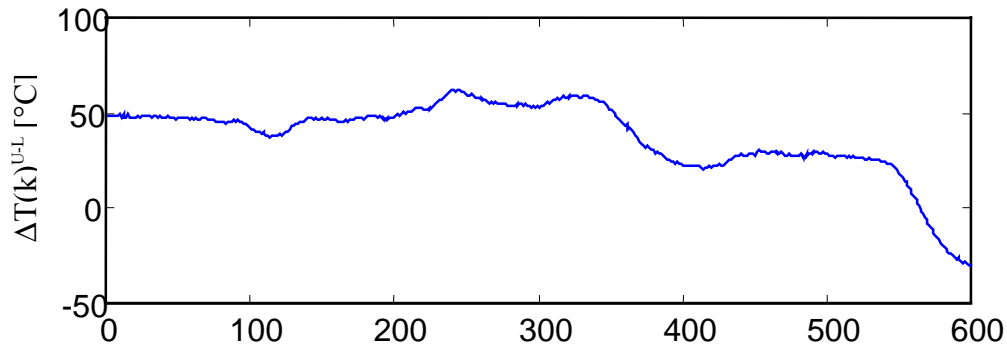


Fig. 4.20d: Difference  $\Delta T(k)^{U-L}$  [5-6]

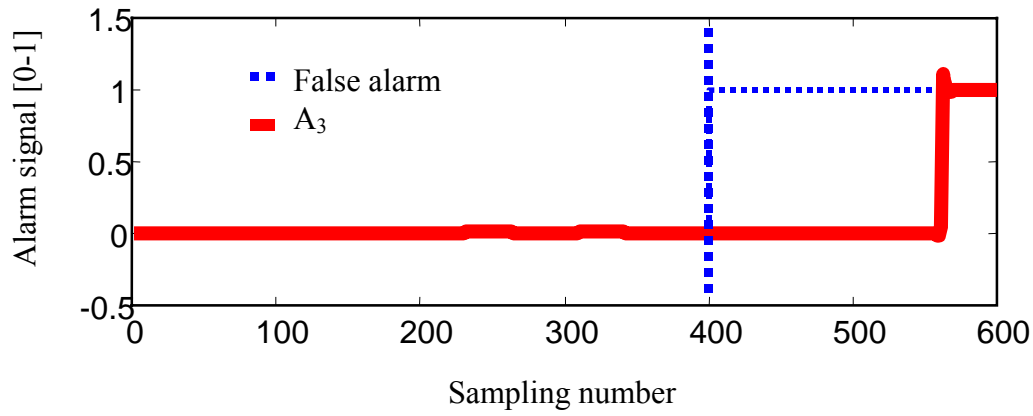


Fig. 4.20e: Real and calculated alarms

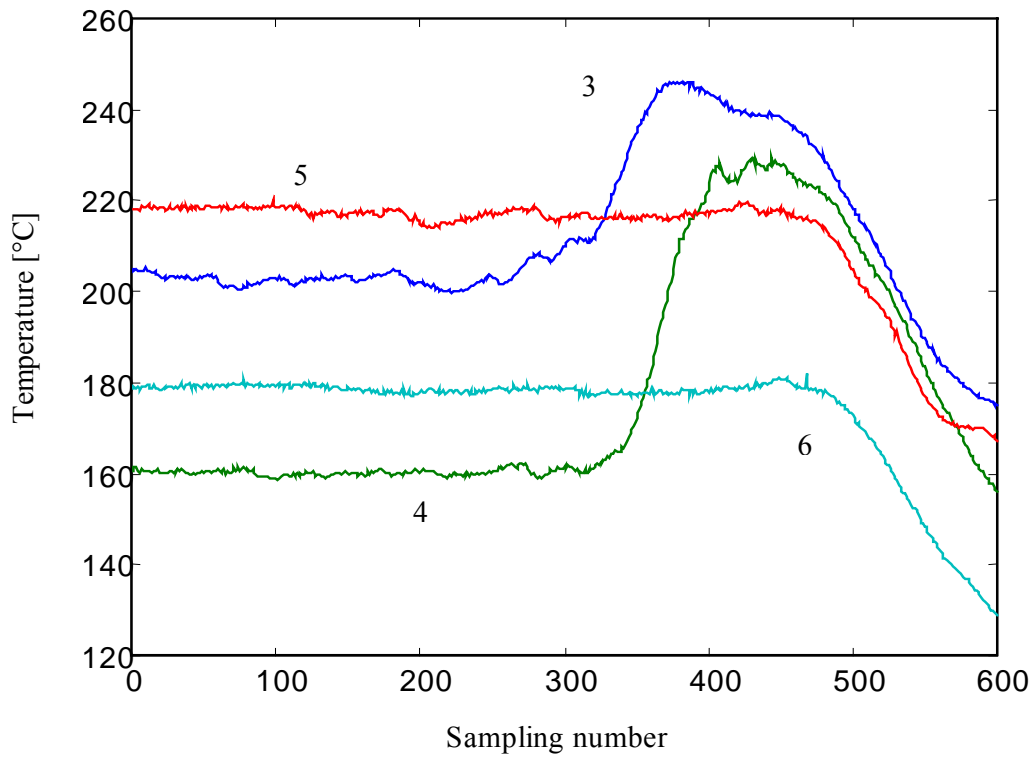


Fig. 4.21a: False breakout Nr 2: Thermocouples[3-4-5-6]

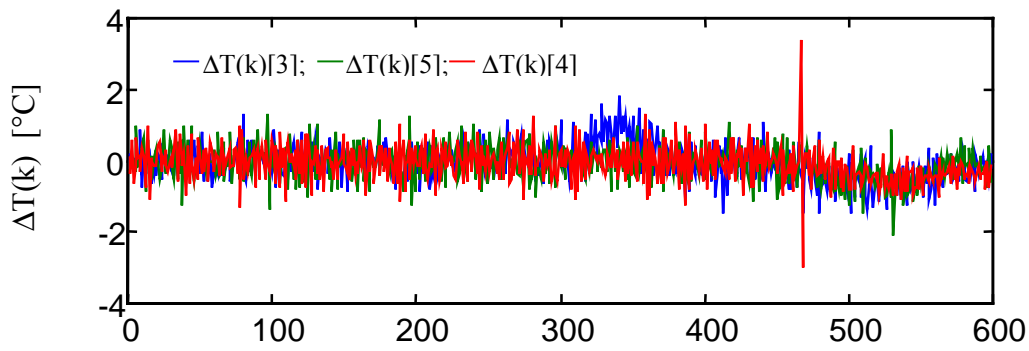


Fig. 4.21b: Differentiation of equ(4.8)

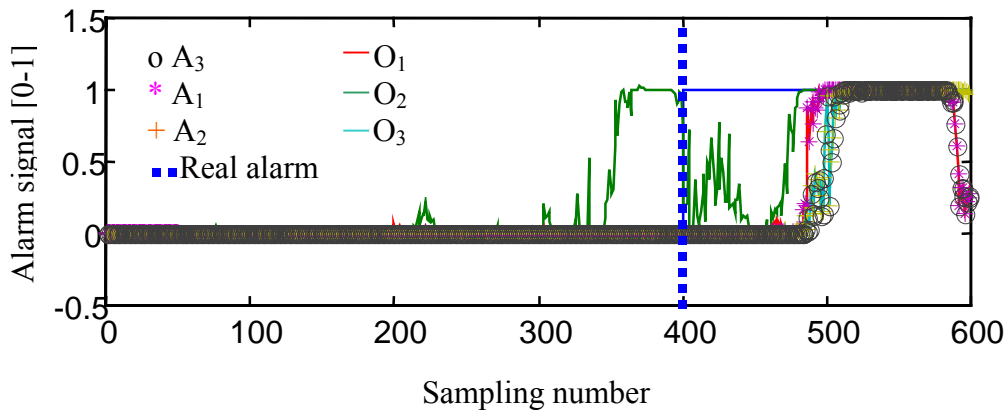


Fig. 4.21c: Real and calculated alarms

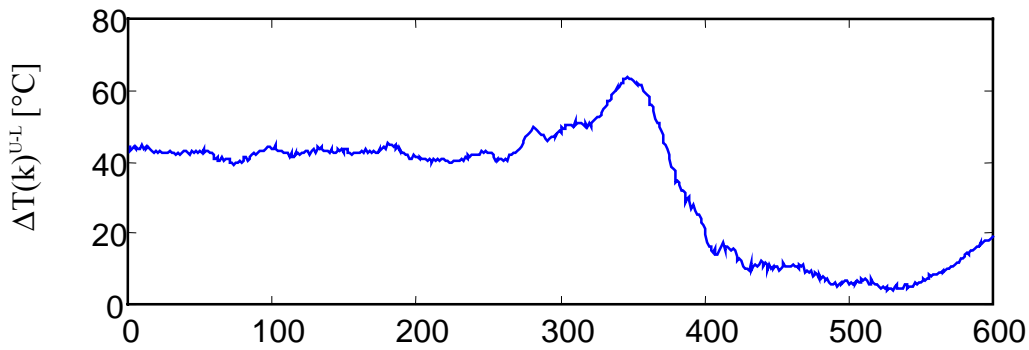


Fig. 4.21d: Difference  $\Delta T(k)^{U-L}$  [3-4]

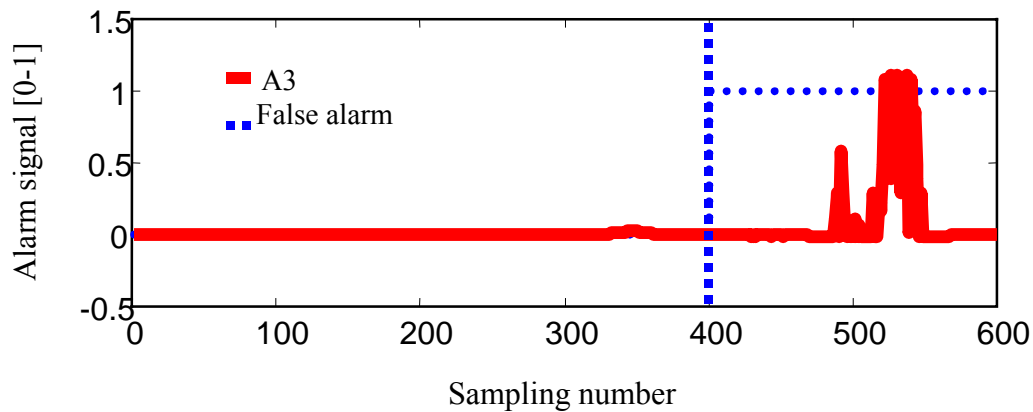


Fig. 4.21e: Real and calculated alarms

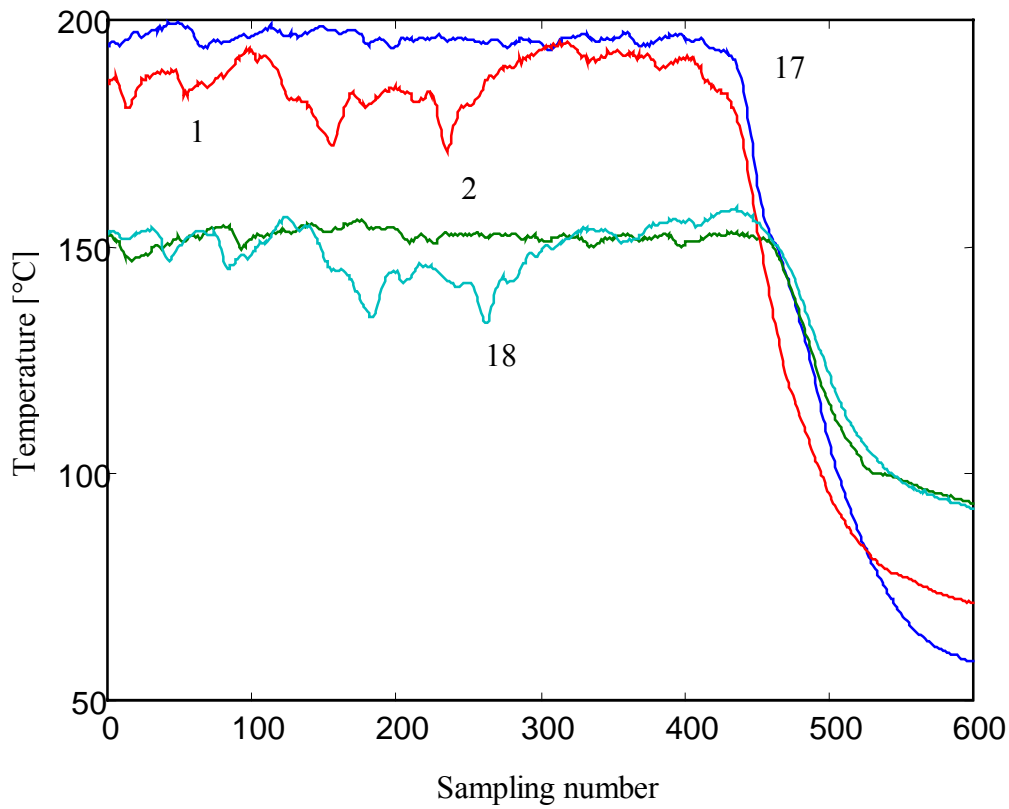


Fig. 4.22a: False alarm Nr 3: Thermocouple node [17-1-18-2]

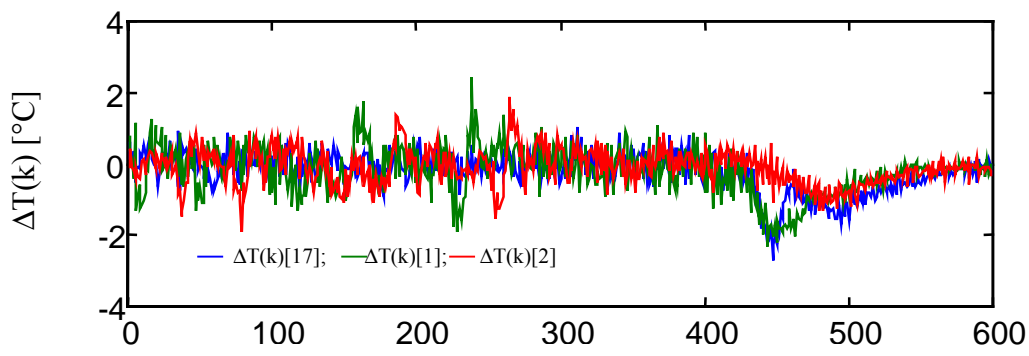


Fig. 4.22b: Differentiation of equ(4.8)

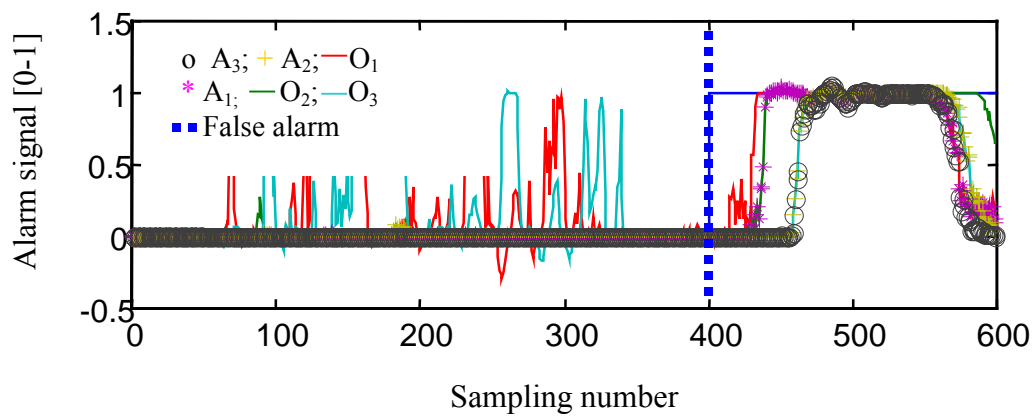


Fig. 4.22c: Calculated and real alarms

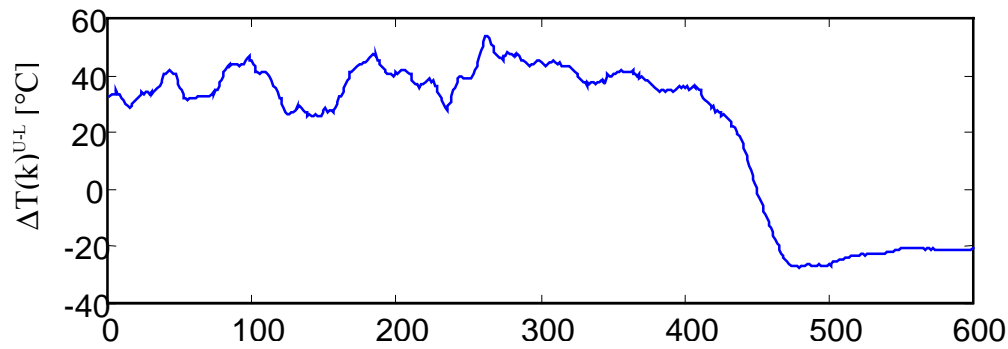
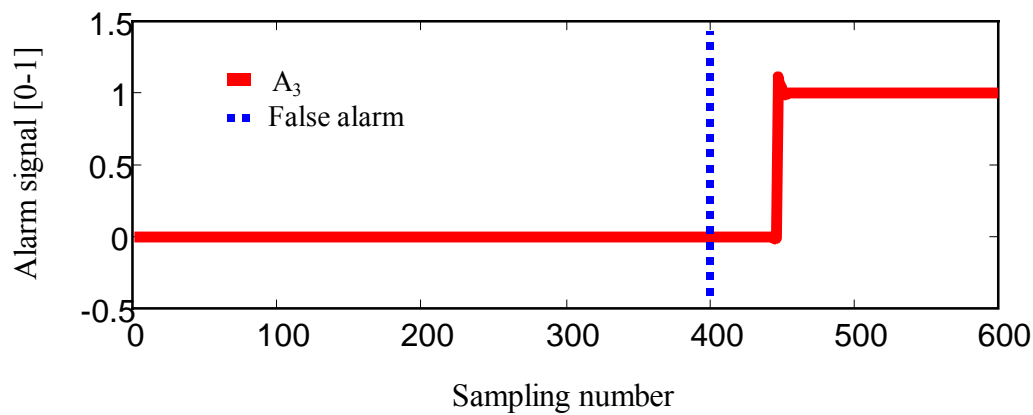
Fig. 4.22d: Difference  $\Delta T(k)^{U-L}[1-2]$ 

Fig. 4.22e: Real and calculated alarms

### 4.3.5 Results and analysis

As presented in **Table 4.3**, the NN breakout system ability was tested through (10) real breakouts detected by the conventional system used by EKO STAHL. NN models have investigated all breakouts detected by the conventional system. The detection is achieved by the upper, lower and upper-lower processing units. In this case, NN and conventional systems are equivalent.

System	Sticker	Misclassification	Breakout
Conventional	10	4	0
NN model	10	0	0

Table 4.3: Real breakout analysis

Sticker : Alarm has been generated and was justified

Misclassification : Alarm has been generated but was not justified

Breakout : A breakout occurred but no alarm has been generated

In the case of false breakout detection by the conventional system (misclassification), the NN model has been tested through four (4) false breakouts detected by the EKO STAHL conventional system. The NN model has not detected all false alarms. In this case the NN model has a greater ability not to take into account the field temperature variations that do not generate a breakout.

As presented in Table 4.3, the objective of reducing the false alarm rate has been achieved. The NN breakout detection system has been tested through real data. The obtained results confirm an improvement.

## 5 CONTROL OF HEAT TRANSFER IN SECONDARY COOLING

### 5.1 Introduction

In continuous casting, the cooling–solidification process is based on the adaptation of heat transfer which is directly connected to casting speed. In practice, the casting speed is continuously changed by the casting operator on the basis of thermal loss and chemical composition of steel in the tundish. Most of the control schemes are based on the static relation between casting speed and water flow rate in each cooling zone. This constitutes an open loop that does not consider surface temperature variation which is an important parameter for slab quality. In steelmaking, changes in the casting speed affect the entire heat transfer. An optimal operation requires an adjustment of the process variables, i. e., global heat transfer that depends on the operating point, steel grades, water flow rate and most importantly the casting speed. A learning NN allows the identification and the control of a non-linear heat transfer model in the continuous casting process. A heat transfer model was developed using the dynamic heat balance. A comparison between the experimental open loop results and those of the model simulation is considered. From the adaptation, the model is used for controlling the slab surface temperature in the closed loop using NN technology and PID controllers. Temperature stability is very important especially for casting crack sensitive steel grades. Such performance cannot be achieved without the NN technology, as the process features an important non-linearity and disturbances in casting speed, water temperature and specific heat coefficients.

In the steel industry, the continuous casting process results in the formation of steel strands obtained by the passage of liquid steel through several cooling zones. In this phase, the liquid steel is poured into the mould, cooled by water, and transferred through the cooling zones at a constant casting speed and a constant water flow rate. The final quality of the solidified strand depends on its thermal history within the different cooling zones. It is, therefore, necessary to control the cooling based on the casting events, variations of thermal loss, casting speed and different heat dissipation. In most industrial applications, the appropriate cooling rate is adjusted on the basis of the casting speed by linear correlation and the anticipated casting speed effect on the temperature in the cooling zones [1-3]. This control approach is inefficient in transient response as the thermal diffusion and the relation between water flow rate and

casting speed is non-linear and an unsteady state function [14-16]. At present, this control approach is only an open loop linear static compensation.

During the cooling phase, strands maintained at high temperature are in direct contact with the cooling water which leads to the formation of oxides called calamine involving variations in heat exchange and thus affecting surface temperature stability. From the results of metallurgical studies, surface defects such as cracks and segregations are generated due to variations in temperature in the different cooling zones. Thus it is essential to control the temperature in the cooling zones. The appropriate application of water cooling is of great importance as it significantly affects the casting quality. The variation of temperature in the cooling zone causes a variety of problems such as residual stress, coarsening of microstructure and plastic deformation. The temperature at the embedding point should be out of the low ductility range [2, 3, 21] that is characterised by a high level of surface oxidation which generates instability of the measured surface temperature.

The aim of the present work has been to develop a closed loop control scheme for temperature in all cooling zones. This control approach takes into account the overall heat transfer changes, i. e., casting speed variations and effects. Such a control scheme is based on NN identification and control. Due to their ability in approximating an arbitrary non-linear function, neural networks have become an attractive means for modelling complex non-linear processes such as strand cooling in continuous casting. Numerous neural network models and their corresponding learning strategies, particularly multilayered feed forward neural networks with back-propagation learning algorithms, have been proposed to identify the strand surface temperature in continuous casting. Our investigation is based on the on-line adaptive neural network method which is applied in this work to compute an optimal iterative control law [48, 113].

## 5.2 Simplified heat transfer control model [13, 23, 114-117]

**Fig. 5.1** illustrates the cooling-solidification process control in continuous casting.

Each cooling zone is characterised by temperature  $T_i(t)$ , flow water rate  $q_i(t)$  and length of the zone ( $l_i$ ).



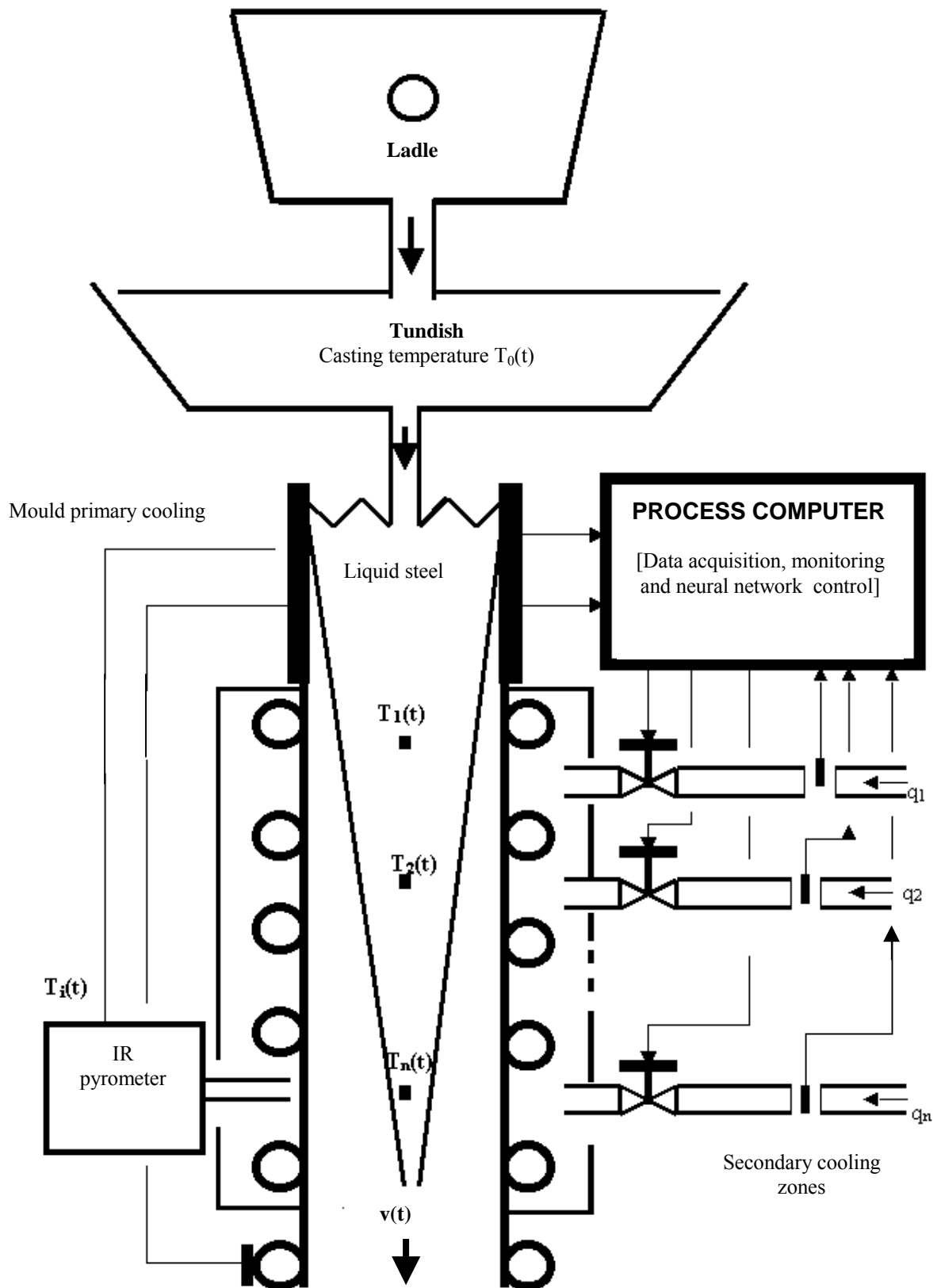


Fig. 5.1: Principle of continuous casting process control

Steel flows into the mould at a temperature  $T_0(t)$ , called casting temperature, and at a casting speed  $v(t)$ .

The solidified strand is characterised by:

- Strand density ( $\rho$ )
- Strand specific heat ( $C_{pi}$ )
- Geometrical characteristics ( $L, h$  see **Fig. 5.3**)

The cooling changes are characterised by:

- Water specific heat ( $C_{pe}$ )
- Water temperature ( $T_e$ )

The thermal balance in the dynamic regime for every zone is given as:

$$m_i C_{pi} \frac{dT_i(t)}{dt} = q_m(t) C_{pi} (T_{i-1}(t) - T_i(t)) - q_i(t) C_{pe} (T_i(t) - T_e) \quad (5.1)$$

where

$$m_i = \rho L h l_i, \quad q_m(t) = \rho L h v(t)$$

We consider  $C_{pi}$ ,  $C_{pe}$ ,  $m_i$ ,  $\rho$  and  $T_e$  constant.

A second order variation of the equation (5.1) is written as:

$$\begin{aligned} \frac{d^2 T_i(t)}{dt^2} = & \frac{C_{pi}}{m_i C_{pi}} (T_{i-1}(t) - T_i(t)) \rho L h \frac{dv(t)}{dt} + \frac{C_{pi} \rho L h v(t)}{m_i C_{pi}} \left( \frac{dT_{i-1}(t)}{dt} - \frac{dT_i(t)}{dt} \right) \\ & - \frac{C_{pe}}{m_i C_{pi}} (T_i(t) - T_e) \frac{dq_i(t)}{dt} - \frac{q_i(t) C_{pe}}{m_i C_{pi}} \frac{dT_i(t)}{dt} \end{aligned} \quad (5.2)$$

$$\frac{dT_i(t)}{dt} \approx \frac{T_i(t) - T_i(t - \Delta t)}{\Delta t} \quad (5.3)$$

where  $\Delta t$  is the sampling time (the sampling number is a multiple of the sampling time).

After transformation we obtain:

$$T_i(k) = A^{-1} (B T_i(k-1) + C T_i(k-2) + D T_{i-1}(k) + E T_{i-1}(k-1) + F) \quad (5.4)$$

where,

$$A = \Delta t^{-2} + \Delta q_m(k)a_1\Delta t^{-1} + a_2q_m(k)\Delta t^{-1} + a_3\Delta t^{-1}\Delta q_i(k) + a_3\Delta t^{-1}q_i(k);$$

$$B = 2\Delta t^{-2} + q_m(k)a_2\Delta t^{-1} + a_3\Delta t^{-1}q_i(k)$$

$$C = \Delta t^{-2}; D = a_1\Delta t^{-1}\Delta q_m(k) + a_2q_m(k)\Delta t^{-1}; E = -a_2q_m(k)\Delta t^{-1}; \quad F = -a_3\Delta q_i(k)T_e\Delta t^{-1};$$

$$a_1 = C_{p_i}m_i^{-1}; \quad a_2 = C_{p_i}m_i^{-1}; \quad a_3 = C_{p_e}m_i^{-1}C_{p_i}^{-1}; \quad \Delta q_i(k) = q_i(k) - q_i(k-1);$$

$$\Delta q_m(k) = q_m(k) - q_m(k-1)$$

Equation (5.2) is a non-linear relation, describing temperature variations in the zones (i), (i-1), and the casting speed and flow rate of cooling water in the zones (i), (i-1). It also considers the coupling due to zone interactions. The main influences on the strand surface temperature are the water flow rate, the strand specific heat coefficient ( $C_{p_i}$ ), the specific heat coefficient of water ( $C_{p_e}$ ), the water temperature ( $T_e$ ) and the casting speed ( $v(k)$ ). Other variables are not crucial in casting operation.

### 5.3 Measurement and experimental data analysis

The simulation results obtained from the model described by equation (5.2) have been compared with measured results on the continuous casting process computer.

The measurement principle is illustrated in **Fig. 5.2** and achieved at the EKO STAHL (Germany) casting shop.

An infrared pyrometer was installed in the cooling zone at 2.5 m below the level of the mould bath, which is supplied with compressed air for its own cooling.

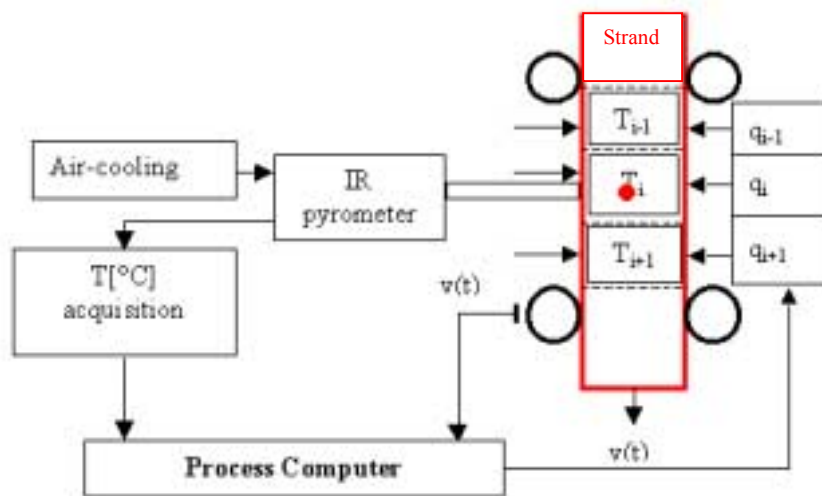


Fig. 5.2: Principle of temperature measurement and closed loop control

The measured signals of the pyrometer range from 4 to 20 mA corresponding to a temperature range of 900 – 1300 °C.

The sampling time for all process variables is equal to 8 s.

The constants and structure of the model are shown in **Fig. 5.3**. The calculated and measured temperatures obtained by the model are shown in **Fig. 5.4**. Process dynamics described in **Fig. 5.4** have been used for testing the model temperature response. It has been noticed that an adequate choice of initial conditions for the model described by equation (5.2) results in a static error approximately equal to zero. In the present case, the initial value of the casting temperature was equivalent to 1532°C. The complex metallurgical reactions such as strand surface oxidation disturb the temperature measurement due to the variation of the specific heat coefficient ( $C_{p_i}$ ) of the steel.

The change in water quality affects the specific heat coefficient ( $C_{p_e}$ ) of the water. The casting temperature variation ( $T_0(t)$ ) has a considerable effect on the internal stress and defects of the solidified strand, but it has a negligible influence on the strand surface temperature [3, 9]. As shown in **Fig. 5.4**, temperature variation of the sampling number 520 approximately is generated by a reduction of casting speed according to a casting incident.

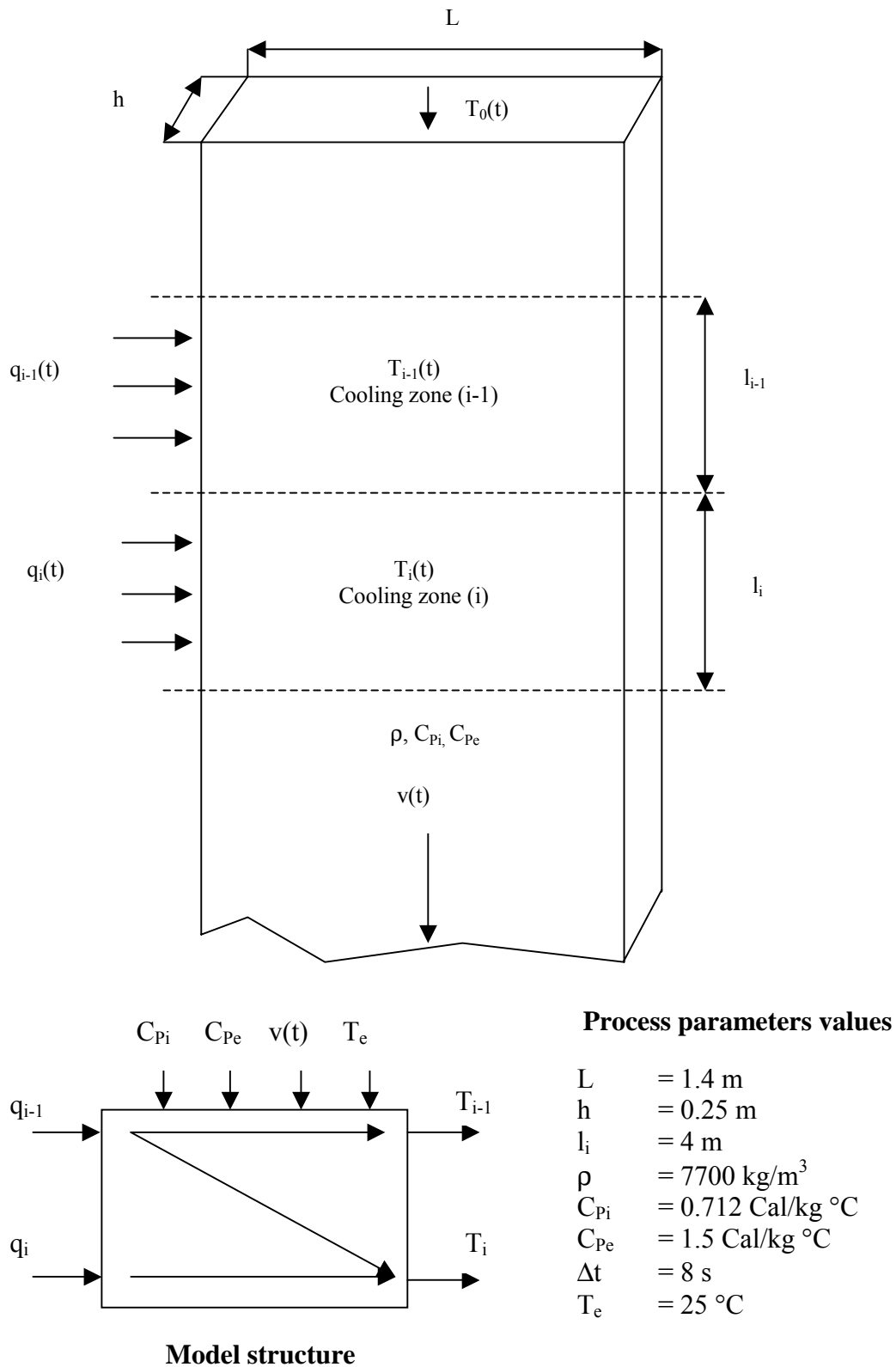


Fig. 5.3: Cooling zone structure

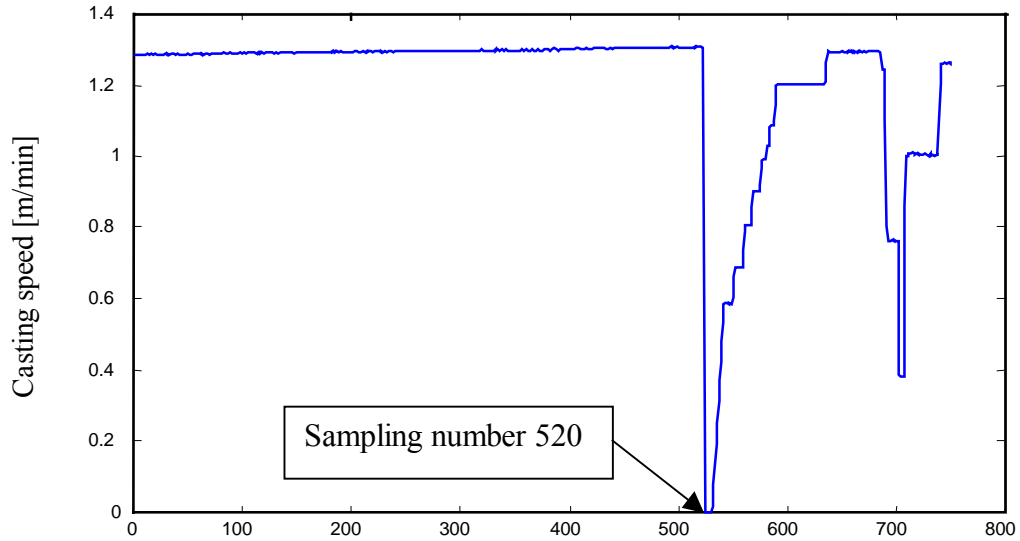


Fig. 5.4a: Dynamics of casting speed

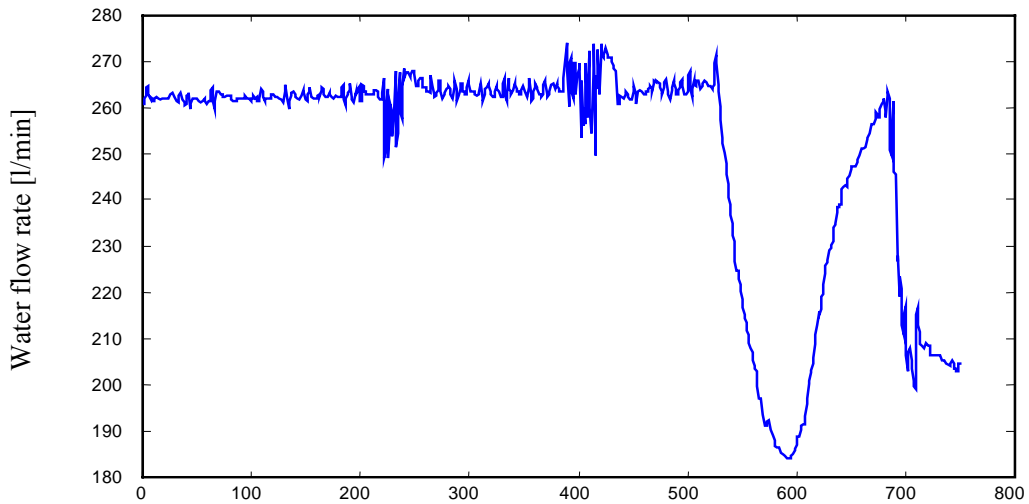


Fig. 5.4b: Water flow rate dynamics

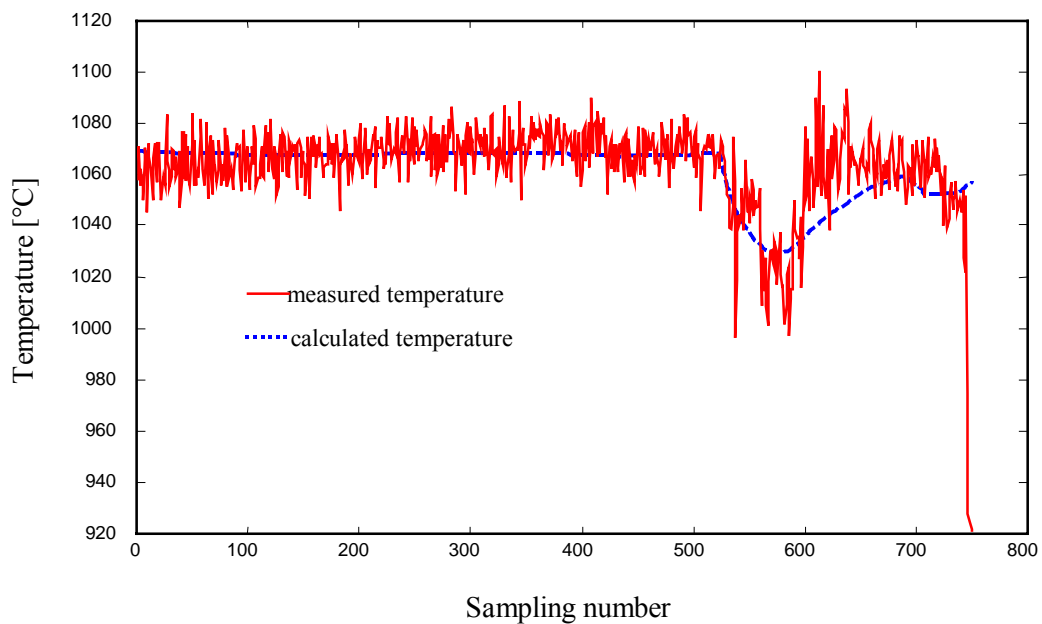


Fig. 5.4c: Measured and calculated temperatures

## 5.4 Conventional control [114-118]

### 5.4.1 Feed forward control

The control scheme shown in **Fig. 5.5** is currently applied to the majority of processes for a compensation of the casting speed variations carried out by a linear and stationary anticipation, where  $q_0(t)$  is the minimal water flow rate. This control approach is operated in a linear open loop via feed forward. In this case, there is inevitably an important static error that cannot be accepted for a specific steel grade. The control objective is the stabilisation of the temperature  $T_i(t)$  at the desired value. From equation (5.1) it can be seen where

$$\frac{dT_i(t)}{dt} = 0 \Rightarrow q_m(t) \cdot C_{Pi} [T_{i-1}(t) - T_i(t)] = q_i(t) \cdot C_{Pe} [T_i(t) - T_e] \quad (5.5)$$

a condition is reached represented by

$$K^i = \lim_{t \rightarrow \infty} \frac{q_i(t)}{v(t)} = \frac{\rho L h C_{Pi} (T_{i-1} - T_i)}{C_{Pe} (T_i - T_e)}$$

In a steady state regime, the control input is for each cooling zone (i) defined by:

$$q_i(t) = K^i v(t) \quad (5.6)$$

where  $K^i$  is the compensation constant. The implementation of this control law allows to obtain the results given in **Fig. 5.6**. The variation of casting speed has induced a static error of surface temperature. This scheme is an open loop control system without any feedback. The important fluctuations of strand surface temperature would be able to increase the defect if their peaks and static error exceed a fixed threshold.

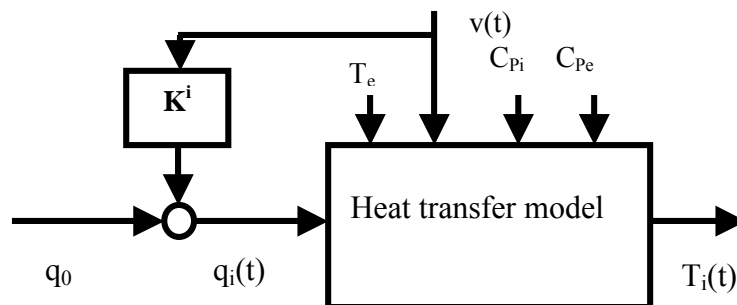


Fig. 5.5: Principle of feed forward control

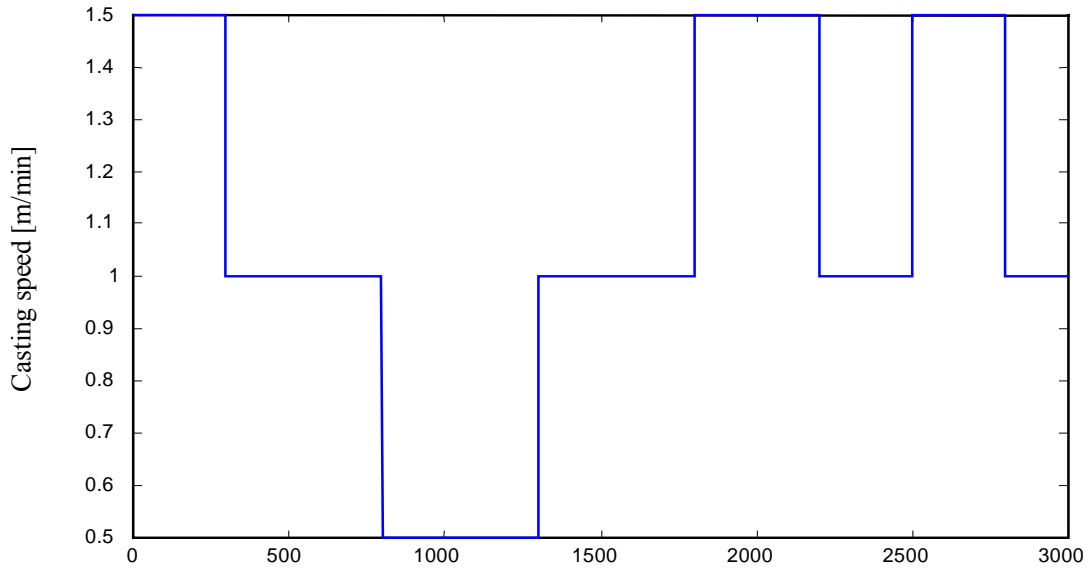


Fig. 5.6a: Casting speed

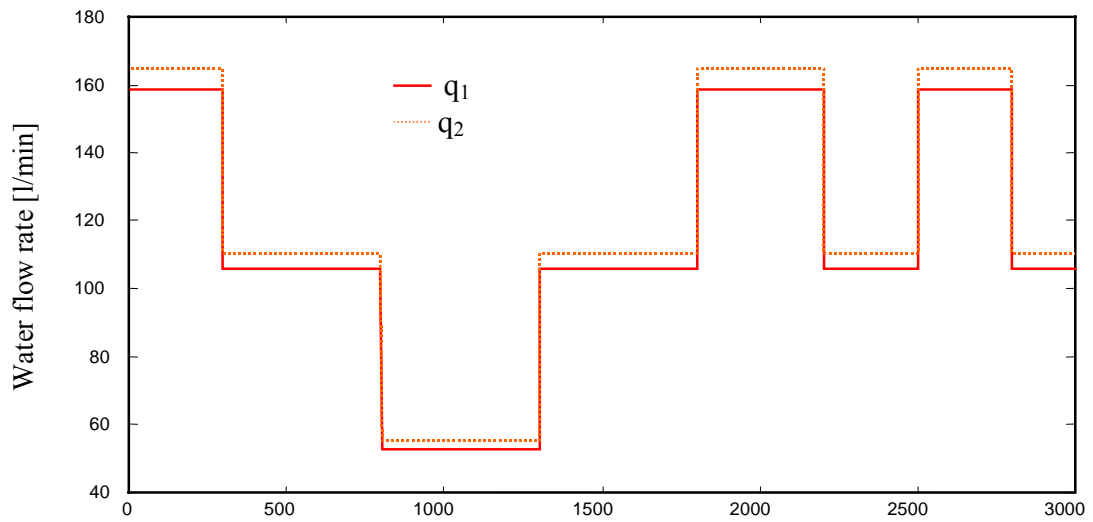


Fig. 5.6b: Control inputs

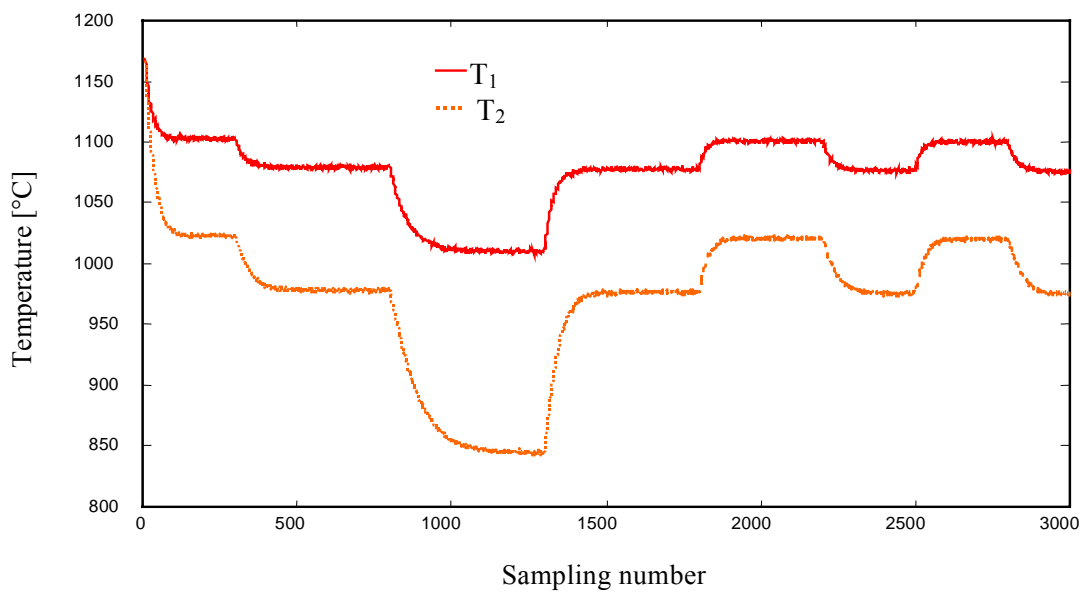


Fig. 5.6c: Controlled surface temperature



### 5.4.2 Proportional, integral and derivative digital control (PID) [119]

**Fig. 5.7** gives the closed loop structure using a PID controller. The tracking error for each cooling zone (i) is defined by the following equation:

$$e_i(k) = Tg_i(k) - T_i(k) \quad (5.7)$$

Where,  $Tg_i(k)$ , is the set point of each temperature cooling zone (i). The PID digital control attains a stable closed loop by an optimal tuning of PID actions. The control input is the water flow rate  $q_i(k)$ .

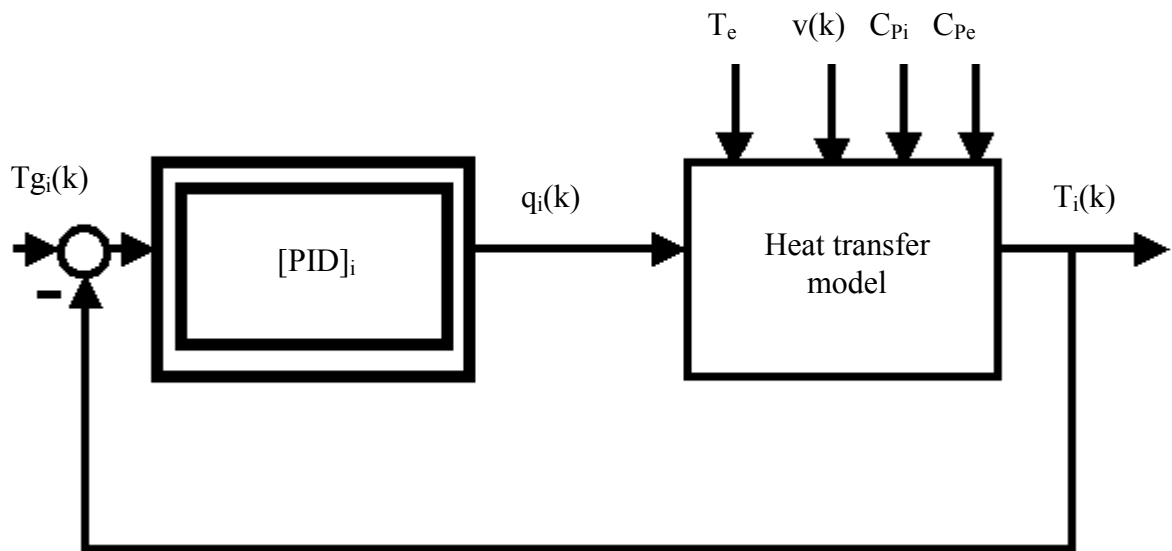


Fig. 5.7: Structure of PID control

- **Analog PID control**

$$q_i(t) = K_{Ri} \left[ e_i(t) + \frac{1}{T_{Ni}} \int e_i(t) dt + T_{Vi} \frac{de_i(t)}{dt} \right] \quad (5.8)$$

- **Analog PD control for  $T_{Ni} \rightarrow \infty$**

$$q_i(t) = K_{Ri} \left[ e_i(t) + T_{Vi} \frac{de_i(t)}{dt} \right] \quad (5.9)$$

- **Analog PI control for  $T_{Vi}=0$**

$$q_i(t) = K_{Ri} \left[ e_i(t) + \frac{1}{T_{Ni}} \int e_i(t) dt \right] \quad (5.10)$$

$K_{Ri}$  is the proportional action,  $T_{Ni}$  is the integral action and  $T_{Vi}$  is the derivative action.

A digital control input is obtained by a discretisation of the derivative and the integral operators. From equ(5.8), the following digital control algorithms are obtained

- **Digital PID control**

$$q_i(k) = K_{Ri} \left[ e_i(k) + \frac{1}{T_{Ni}} \sum_{j=0}^{k-1} e_i(j) \Delta t + T_{Vi} \frac{e_i(k) - e_i(k-1)}{\Delta t} \right] \quad (5.11)$$

$$q_i(k-1) = K_{Ri} \left[ e_i(k-1) + \frac{1}{T_{Ni}} \sum_{j=0}^{k-2} e_i(j) \Delta t + T_{Vi} \frac{e_i(k-1) - e_i(k-2)}{\Delta t} \right] \quad (5.12)$$

From equ (5.11) and equ(5.12), we obtain the recursive form:

$$q_i(k) = q_i(k-1) + K_{Ri} \left[ \left(1 + \frac{T_{Vi}}{\Delta t}\right) e_i(k) - \left(1 - \frac{\Delta t}{T_{Ni}} + \frac{2T_{Vi}}{\Delta t}\right) e_i(k-1) + \frac{T_{Vi}}{\Delta t} e_i(k-2) \right] \quad (5.13)$$

- **Digital PD control**

$$q_i(k) = K_{Ri} \left[ \left(1 + \frac{T_{Vi}}{\Delta t}\right) e_i(k) - \frac{T_{Vi}}{\Delta t} e_i(k-1) \right] \quad (5.14)$$

- **Digital PI control**

$$q_i(k) = q_i(k-1) + K_{Ri} \left[ e_i(k) - \left(1 - \frac{\Delta t}{T_{Ni}}\right) e_i(k-1) \right] \quad (5.15)$$

The general form of the control law can be written as:

$$q_i(k) = a_{1i} \cdot q_i(k-1) + b_{0i} \cdot e_i(k) + b_{1i} \cdot e_i(k-1) + b_{2i} \cdot e_i(k-2) \quad (5.16)$$

The stability of the recurrent equation (5.16) depends on the coefficients  $a_{1i}$ ,  $b_{0i}$ ,  $b_{1i}$  and  $b_{2i}$ .

Optimal values of these coefficients form an optimal and stable closed loop. More details are presented in [119]:

$a_{1i} = 1$  : for the PI and PID algorithm

$a_{1i} = 0$  : for the PD algorithm

$b_{0i} = K_{Ri}(1 + T_{Vi}/\Delta t)$ ,  $b_{1i} = K_{Ri}(1 - \Delta t/T_{Ni} + 2T_{Vi}/\Delta t)$  and  $b_{2i} = K_{Ri} \cdot T_{Vi}/\Delta t$

The reference model is a second order system defined by the structural scheme in

**Fig. 5.8** and by the following equation:

$$Tg_i(k+1) = \beta_i Tg_i(k) + \lambda_i Tg_i(k-1) + r_i(k) \quad (5.17)$$

where  $r_i(k)$  is the bounds input to the reference model. The coefficients  $\beta_i$  and  $\lambda_i$  were selected to ensure that the poles are within the unit circle and feature the type of the response achieved by the process. The selected reference model is asymptotically stable assuming that the tracking error tends to zero.

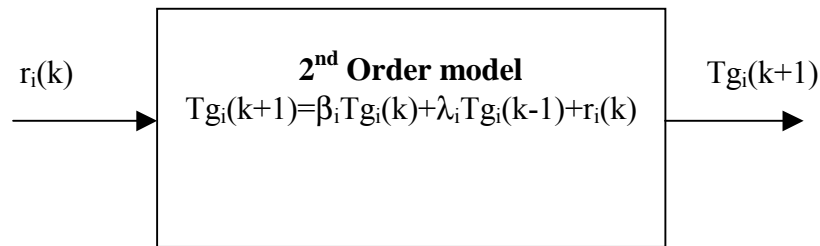


Fig. 5.8: Reference model structure

Appropriate values of  $\lambda_i$  and  $\beta_i$  are obtained through the simulation in view of an optimal closed loop performance according to step variations of  $r_i(k)$ .

After several trials, the optimal values of controller actions ( $K_{Ri}$ ,  $T_{Ni}$  and  $T_{Vi}$ ) are chosen through the simulation. Optimal values of PID actions for the casting speed variations result in a closed loop stability limit for the heat transfer characterized by the variations of  $C_{Pi}$ ,  $C_{Pe}$  and  $T_e$ . **Figs. 5.9** and **5.10** show the closed loop control performance for the variations of casting speed and specific heat coefficients.

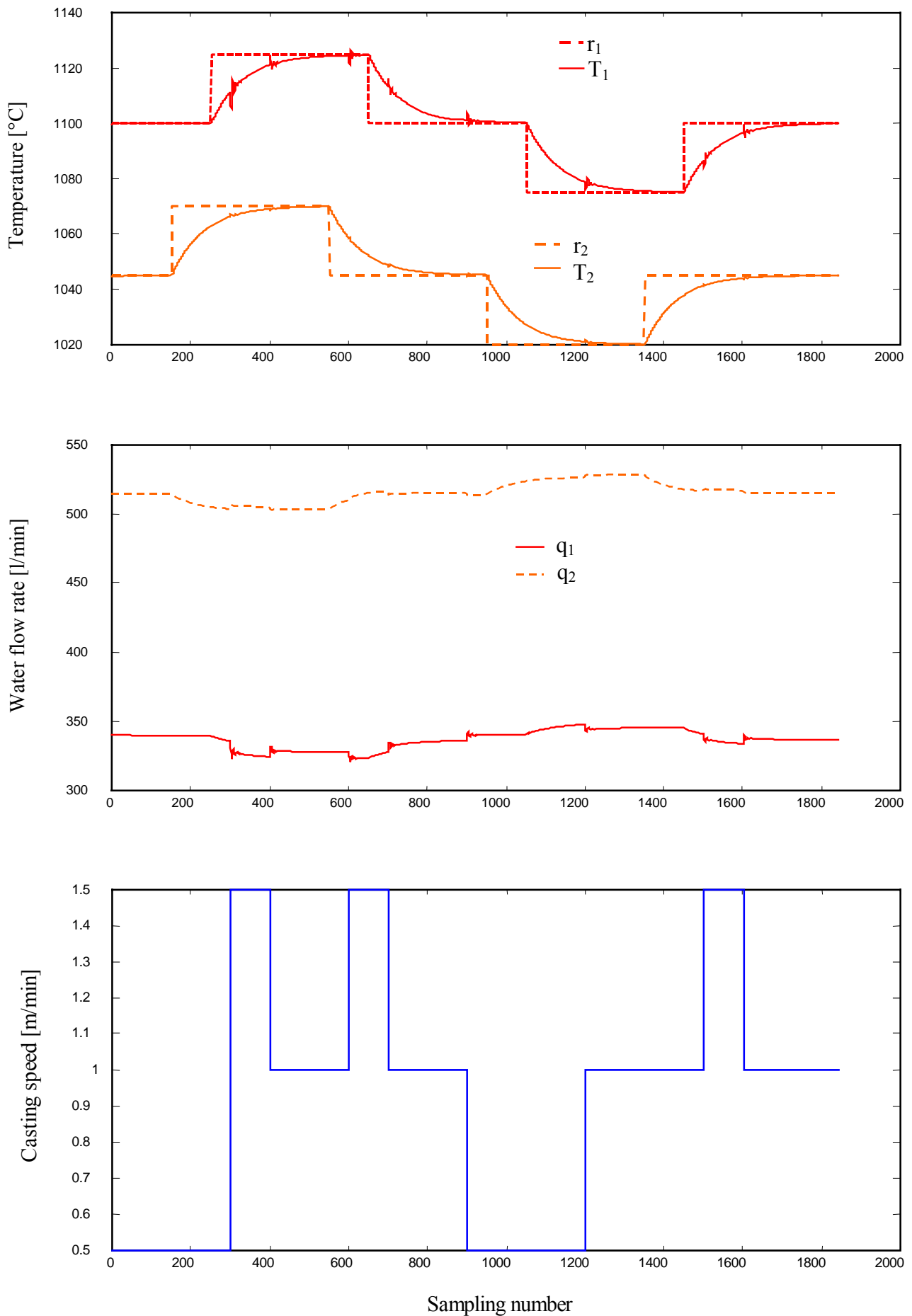
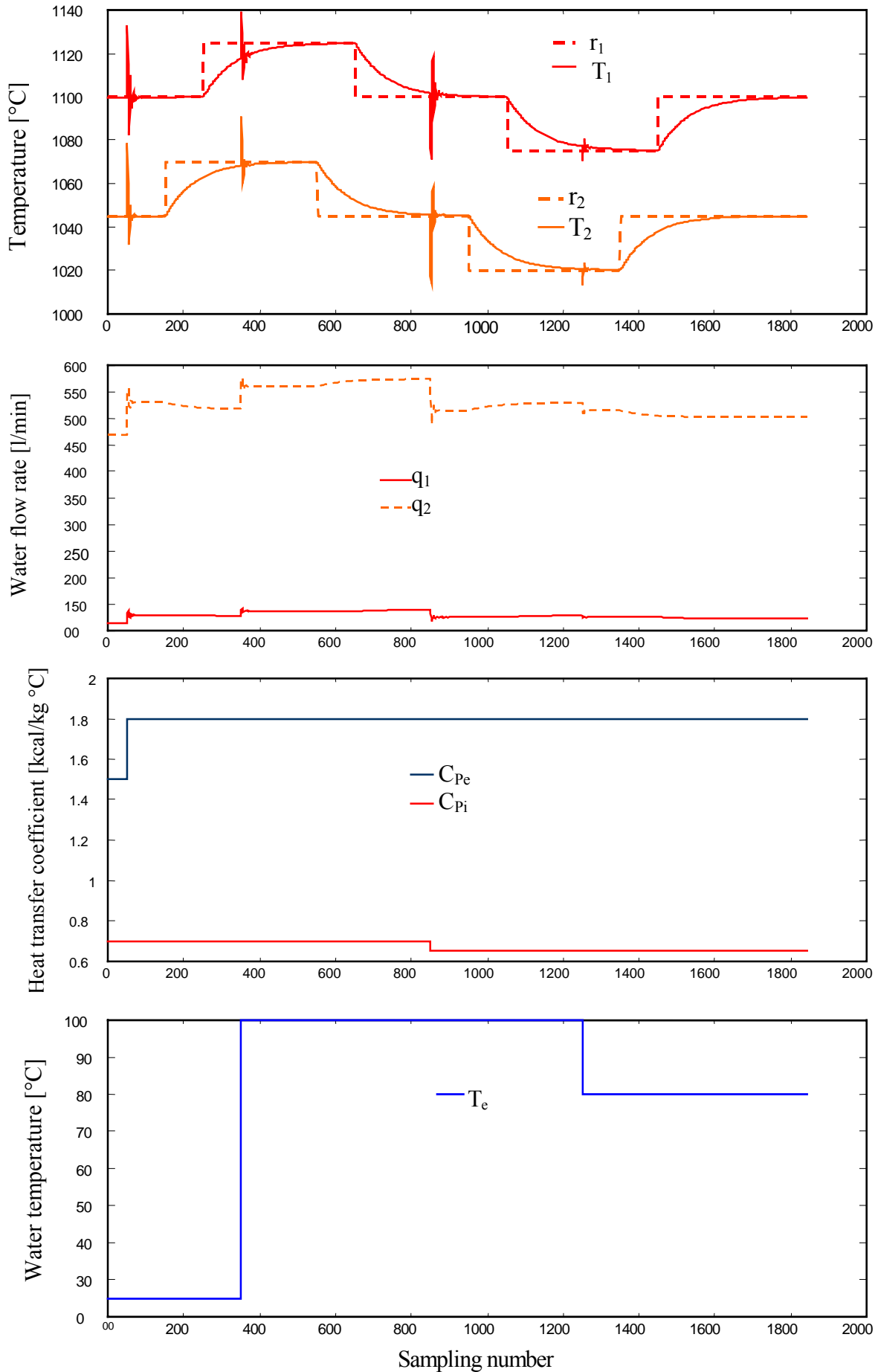


Fig. 5.9: PID closed loop control according to casting speed variations

Fig. 5.10: PID closed loop control according to variations of  $C_{Pi}$ ,  $C_{Pe}$  and  $T_e$

## 5.5 Neural network control

### 5.5.1 Overall structure of the neural identification and control

In this section, iterative on-line adaptive weights of the NN are considered. The control input is estimated to achieve a process output according to the track of a given reference signal. The neural network is used for controlling the heat transfer model, i. e., strand surface temperature is described by equation (5.2). The overall structure of the identification and control is given in **Fig. 5.11**. In a widely used multilayer feed forward network the past process output, the measured perturbations, control input and the past control input are introduced. At first, a feed forward NN identifies the inverse process model. The network weights are initialised by arbitrary values. These values are then used to compute the NN output. The network is trained to generate appropriate weights in order to reduce the error. After convergence after few iteration steps, the obtained NN weights are used to compute the control law.

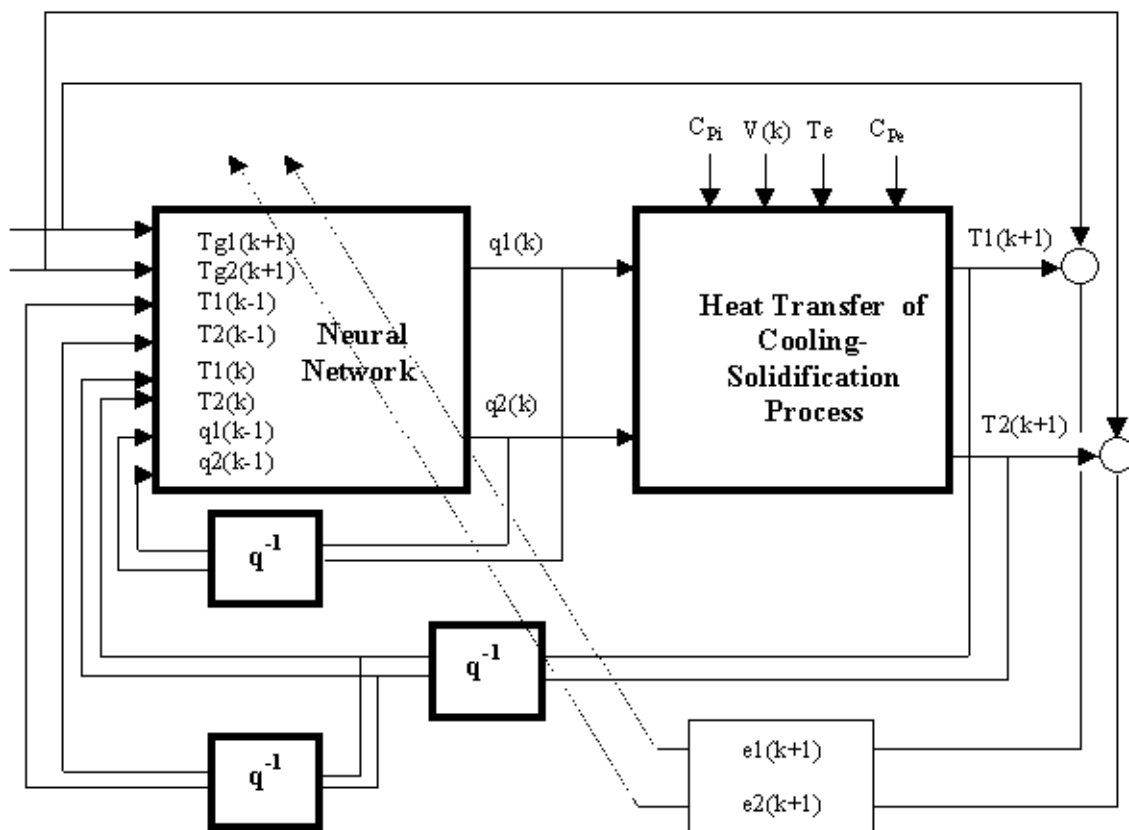


Fig. 5.11: Overall structure control using NN of temperature

For each secondary cooling zone, the inputs of the network are  $[T_i(k-1), T_i(k-2), q_i(k-1), q_i(k-2), v(k-1), v(k-2)]$  and the output is  $T_i(k)$ .

### 5.5.2 Control using neural networks

The objective of the control system is to track the strand surface temperature at the desired values as defined by the optimal operating conditions. The reference model through the trajectory selects the set point dynamics.

The control scheme (**Fig. 5.11**) is used to compute the control law using the weights from the identification process. For each controlled temperature zone, the control law minimises the tracking error.

To ensure that the error signal is equal to zero, the control inputs are inversely estimated by trained NN as:

$$q_i(k) = NN[Tg_{i-1}(k+1), Tg_i(k+1), T_{i-1}(k), T_i(k), T_{i-1}(k-1), T_i(k-1), q_i(k-1), q_{i-1}(k-1)] \quad (5.18)$$

**Figs. 5.12** and **5.13** show the NN closed loop performance for the variation of casting speed, water temperature ( $T_e$ ) and specific heat coefficients ( $C_{Pi}$ ,  $C_{Pe}$ ).

The on-line control algorithm can be summarised as follows:

**Step 0:** Initialise the network weight (-0.5 to +0.5)

#### **Step 1: Identification**

- Acquisition of inputs/outputs
- For each cooling zone (i), calculate the tracking error  $e_i(k) = Tg_i(k) - T_i(k)$ 
  - If  $e_i(k) \cong 0$ ,  $W_{ij}^{new} = W_{ij}^{old}$
  - Else, adjust NN weights using the BP algorithm section (2.2.1.2)

#### **Step 2: Control**

- Using  $W_{ij}^{new}$ , compute the new control inputs  $q_i(k)$ , equation (5.18)
- Next step time  $k=k+1$
- Go to step 1

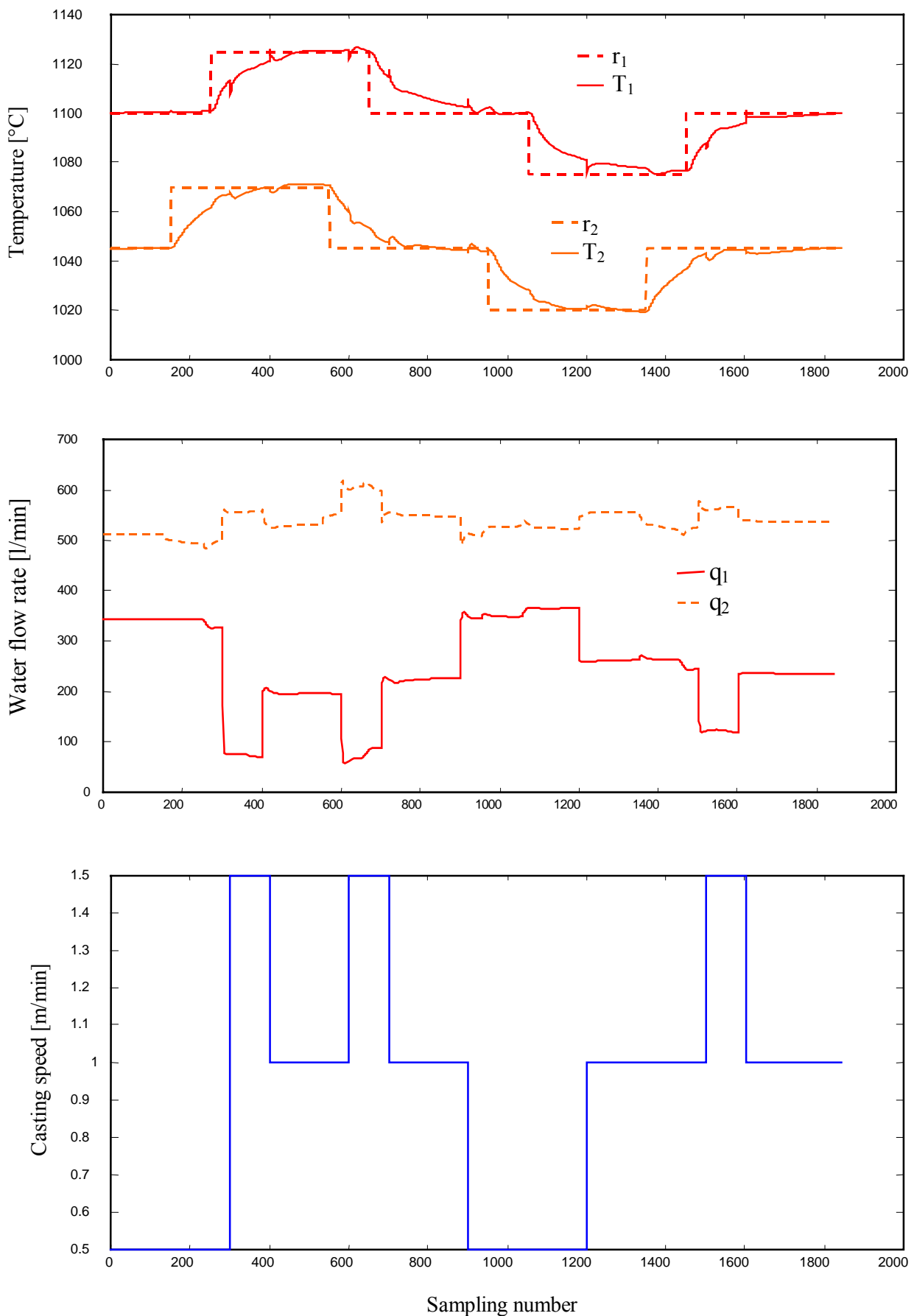


Fig. 5.12: NN control according to casting speed variations



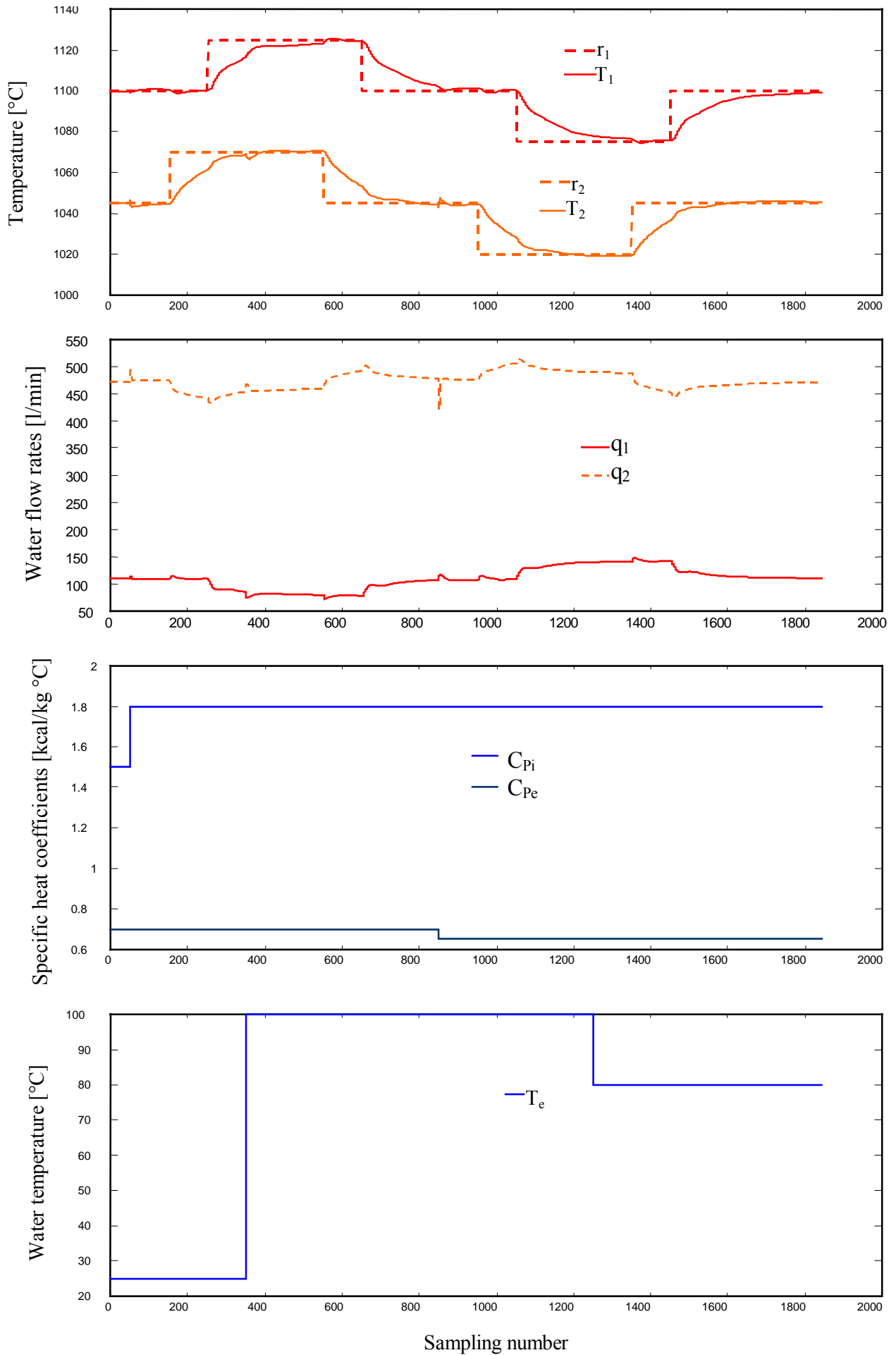


Fig. 5.13: NN control according to variations of  $C_{Pi}$ ,  $C_{Pe}$  and  $T_e$

## 5.6 Results of Simulation

The analysis of the heat transfer dynamic model shows the existence of coupling between cooling zones (i) and (i-1). A multivariable structure with two inputs and two outputs has therefore been selected. The set points  $r_1(k)$  and  $r_2(k)$  are filtered by a second-order model that defines stable closed loop dynamics which reduces the output temperature oscillations  $T_i(k)$  and limits the control saturation of water flow rate  $q_i(k)$ . In the present NN controller, there are 8 nodes,  $yr_1(k+1)$ ,  $yr_2(k+1)$ ,  $T_1(k)$ ,  $T_2(k)$ ,  $T_1(k-1)$ ,  $T_2(k-1)$ ,  $q_1(k-1)$  and  $q_2(k-1)$ , in the input layer. These include 3 in the first hidden layer and 2 in the second hidden layer and 2 NN outputs  $q_1(k)$  and  $q_2(k)$  are chosen to learn the controller dynamics equation (5.18). A learning rate ( $\eta$ ) of 0.01 and a momentum ( $\alpha$ ) of 0.01 were used. The closed loops dynamics must track the second order system equation (5.17) with  $(\lambda_1, \lambda_2)$  of 0.5 and  $(\beta_1, \beta_2)$  of 0.4. For the same variations of casting speed, water temperature and specific heat coefficients, the closed loop performance for the PID and the NN controllers were different. NN control gives an improvement of the surface temperature dynamics compared to PID with reduced tracking error. After several simulations, an optimally tuned PID controller based on the variations of the casting speed has been found, while for other variables ( $T_e$ ,  $C_{pi}$  and  $C_{pe}$ ), the surface temperature behaviour is yet to be improved. This was expected due to the large variations of process parameters and the model non-linearities with some oscillations due mainly to the variations of  $T_e$ ,  $C_{pi}$  and  $C_{pe}$ . In practice, at normal operating conditions, the maximum variation of casting speed ( $|v(k) - v(k-1)|$ ) is limited to 0.3 m/min which doesn't affect the surface temperature stability and reduces the inputs oscillations for NN and PID control. The present performance was obtained by iterative adaption of NN weights using the tracking error.

A closed loop control model has been developed. As shown in the different figures (**Figs. 5.9, 5.10, 5.12 and 5.13**), the closed loop is stable. NN identification and control strategy achieve a robust and stable temperature closed loop control comparatively to the conventional PID.

## 6 FAULT AND QUALITY MONITORING BY DATABASE MODELLING

In continuous casting, on-line quality control systems and process fault detections are generally based on the implementation of mathematical models using the process database. It is usually possible to find a complex relation between the quality or fault and the process parameter variations. Statistical Process Control (SPC) is applied in different steel plants as a tool for process monitoring. SPC is used to obtain the monitoring process parameters which are controlled between a low and high limit defined by the optimal operating conditions using their statistical properties. NN's permit to obtain complex non-linear relationships between quality or defect classification and process parameters [33, 34, 120, 121, 122]. This constitutes an important tool for the optimisation of quality control and fault detection. Quality defects have many origins such as important process parameter deviations and faults due to equipment. In practice, it is sometimes very difficult to find the cause of a fault in the equipment without a real-time machine and equipment monitoring and analysis. Two applications are considered in this chapter, the first is related to breakout alarms and their effect on strand defects and the second is an application of real-time monitoring of casting speed control equipment parameters. This approach of monitoring has been used to find the cause of faults. The aim of this section is the following

- Monitoring of strand defects on the basis of the alarm number detected by the breakout system.
- Real-time monitoring and diagnosis using computerised methods as a tool of fault investigation (data acquisition and modelling using neural networks).

### 6.1 Breakout alarm and quality monitoring in continuous casting

#### 6.1.1 Position of the problem

In chapter 4 a breakout detection system based on temperature field changes using breakout events was developed. It is shown that a breakout can be detected by several alarms together or by individual ones. False alarms are caused by temperature field changes and can be cancelled by advanced modelling. In this section, the relationship between breakout alarms and the importance of defects on the strand surface is considered. Using upper and lower processing units of breakout it is possible to find a complex relation between alarms generated

by different units, breakout importances and models. **Fig. 6.1** defines the principle of alarm breakout and quality management.

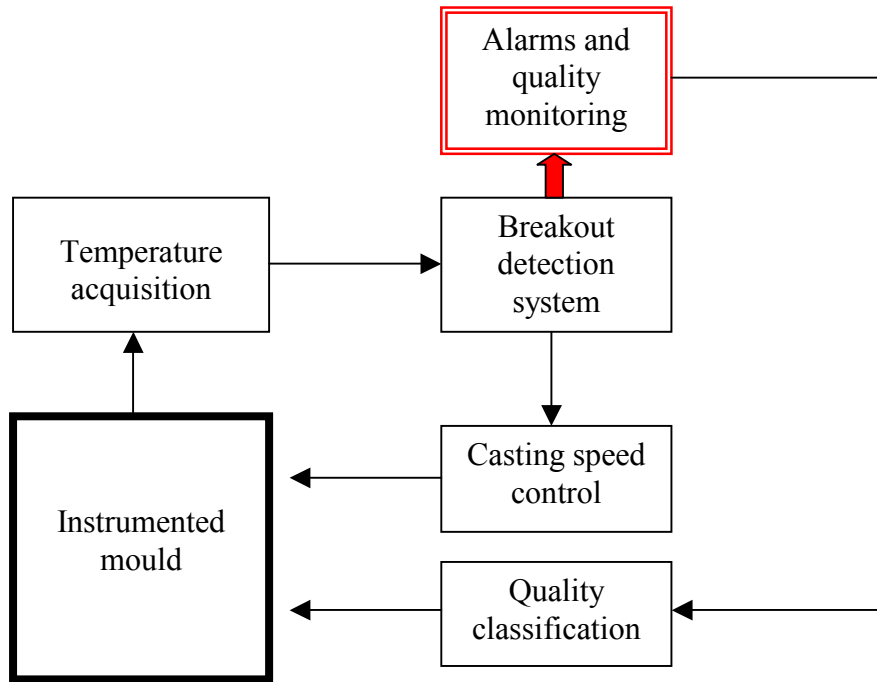


Fig. 6.1. Principle of alarm breakout management and quality monitoring

### 6.1.2. Alarm, breakout propagation and quality monitoring

On the basis of the importance of breakouts (**Fig. 6.2**), the different possibilities for breakout detection include:

- Propagation follow trace 1: Alarm acted by thermocouples upper(j) and upper(j+1)
- Propagation follow trace 2: Alarm acted by thermocouples upper(j) and upper(j+1) and lower(j+1)
- Propagation follow trace 3: Alarm acted by thermocouples upper(j) and lower(j).

A strong breakout is achieved by the detection of all thermocouples together.

False alarm can be also considered. In such a situation there exists no breakout but the surface quality is affected by cracks, for example.

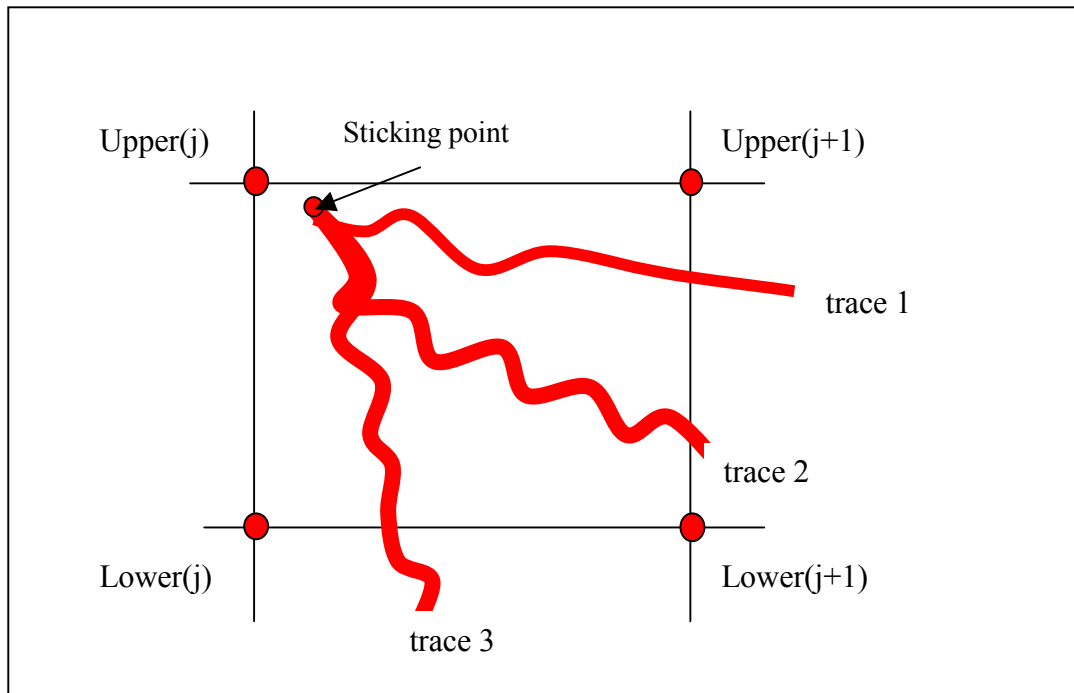


Fig. 6.2: Thermocouple node and breakout propagation

### 6.1.2.1 Classification [120, 122]

The importance of breakout defects depends on their propagation in the temperature field of the mould which is measured by different thermocouples. As shown in **Fig. 4.9** (section 4.3.3), alarm signals and the following logic table (**Table 6.1**) can define breakout strand quality effects:

Alarm $A_1$	Alarm $A_2$	Alarm $A_3$	Alarm $O_4$	Q	Quality classification
0	0	0	0	1	100%[very good]
0	0	0	1	0.75	75%[good]
0	0	1	0	0.5	50%[medium]
0	0	1	0	0.5	50%[medium]
0	1	1	0	0.5	50%[medium]
0	1	1	1	0.5	50%[medium]
1	1	1	1	0	0%[low]
1	1	1	0	0	0%[low]

Table 6.1: Alarms and quality classification

1	0	1	1	0.5	50%[medium]
1	0	1	0	0.5	50%[medium]
1	0	0	0	0.5	50%[medium]
1	0	0	1	0.5	50%[medium]
1	1	0	0	0.5	50%[medium]
1	1	0	1	0.5	50%[medium]
0	1	0	0	0.5	50%[medium]
0	1	0	1	0.5	50%[medium]

Table 6.1: Alarms and quality classification (continued)

### 6.1.2.2 Modelling

The following neural network (**Fig. 6.3**) represents a model according to **Table 6.1**:

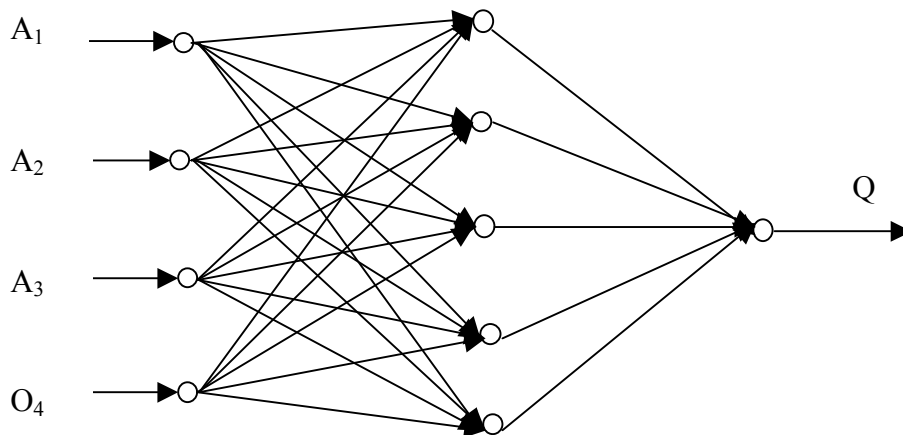


Fig. 6.3: Structure of alarm and quality evaluation using the NN model

We define  $Q$  as:

$$Q = \text{NN}[A_1, A_2, A_3, O_4] \quad (6.1)$$

NN is found using a back-propagation learning algorithm( see **Figs. 6.4a** and **b**)

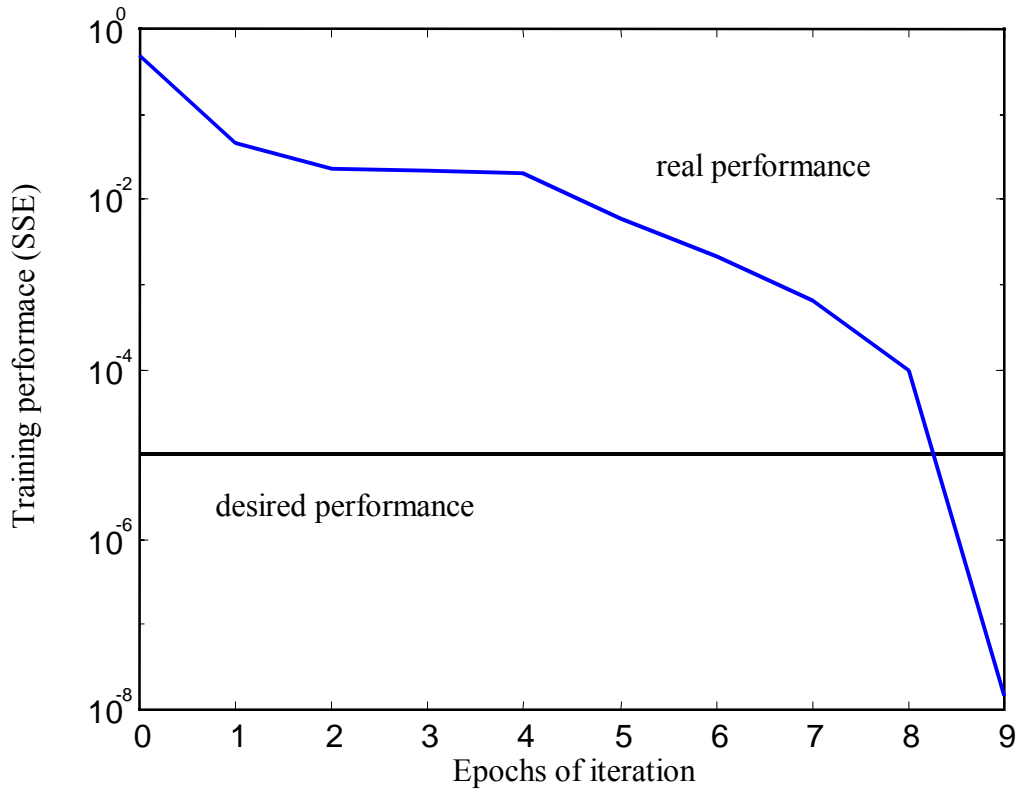


Fig. 6.4a: Learning convergence

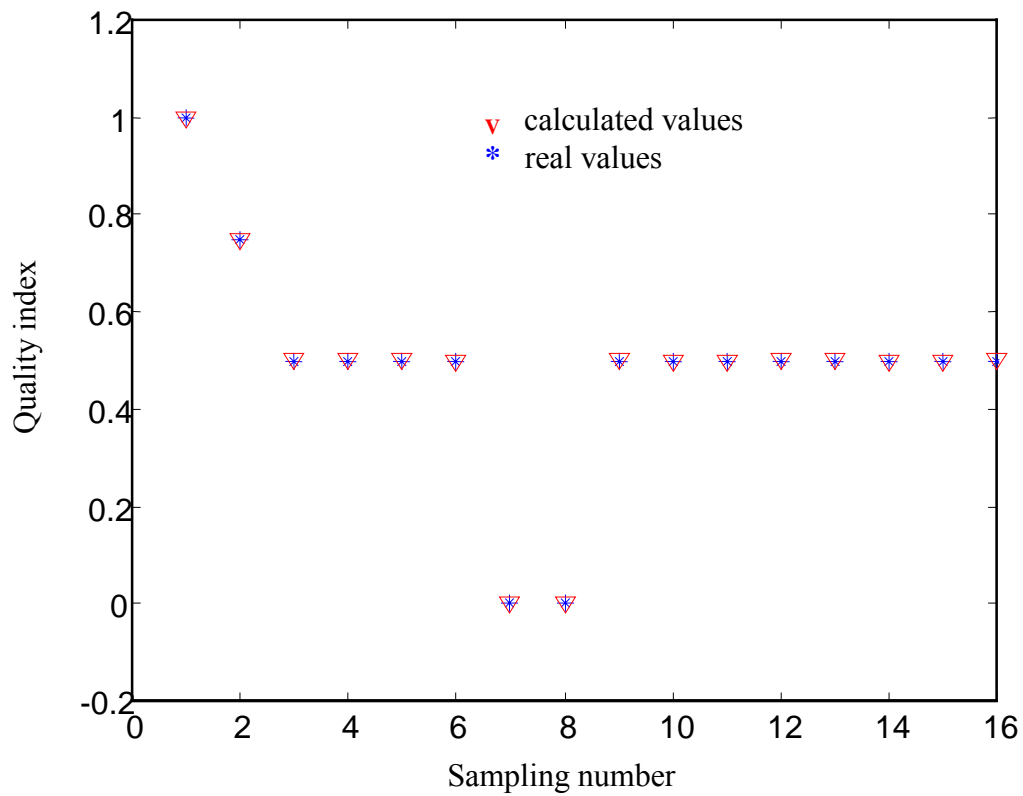


Fig. 6.4b: Real and calculated quality performance

## 6.2 Process monitoring and casting speed control fault detection

### 6.2.1 Position of the problem

The continuous casting process is characterised by several parameters with different physical criteria such as casting temperature and particularly casting speed at different locations of the strand machine. A PID algorithm controls the casting speed.

In this part, an approach to diagnosis and detection of a power defect in the trained casting mechanism has been considered in SIDER- Algeria. This fault caused important disturbances in the production line. The defect is characterised by an important constrain of the steel strand between the guiding rolls. The diagnosis process is based on the real-time monitoring of the rotation equipment parameters with importance given to the casting speed and the motor current. The monitoring is achieved using a rapid computerised data acquisition system. After repair, the fault data bank was used to develop a neural network model for detection and prediction of fault occurrence.

The casting process is a semi-continuous process that transforms the liquid steel to strands which are firstly cooled in different cooling zones before being guided via several driven motors rolls to obtain a semi-product at the end. **Fig. 6.5** shows the principle of the casting and rolling guidance where the different roll speeds are controlled in a closed loop.

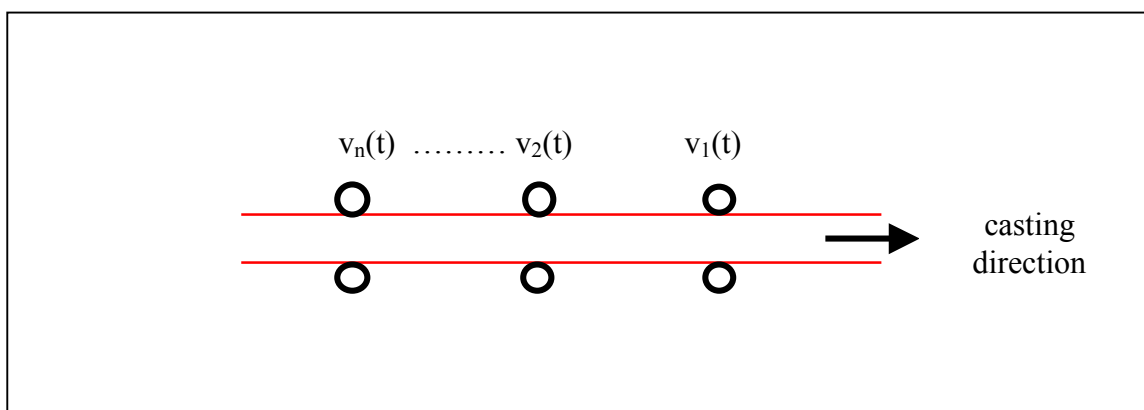


Fig. 6.5: Principle of slab guidance



## 6.2.2 Process analysis and diagnosis

In this work, an approach to process diagnosis and fault detection has been developed using the major parameters of the casting speed control dynamics.

The aims are to

- establish a rapid detection of fault origin at normal operating conditions
- develop a model for detecting and predicting typical faults using the monitoring and modelling techniques.

The treated problem may be due to different factors such as mechanical process parameter and casting speed control. Real-time monitoring of the important parameters is achieved. The present approach may contribute to solve the problem related to the casting speed shutdown when there exists a synchronisation problem between different roll guidances ( $v_1(t)$ ,  $v_2(t)$ ,  $v_n(t)$ ).

**Fig. 6.6** gives the structure of the closed loop casting speed. After several trials, monitoring of the main parameters such as the casting speed and the driving current of the final rotation units number one (Nr 1) and number two (Nr 2) is considered.

The principle of data acquisition, monitoring and diagnosis is given in **Fig. 6.6**.

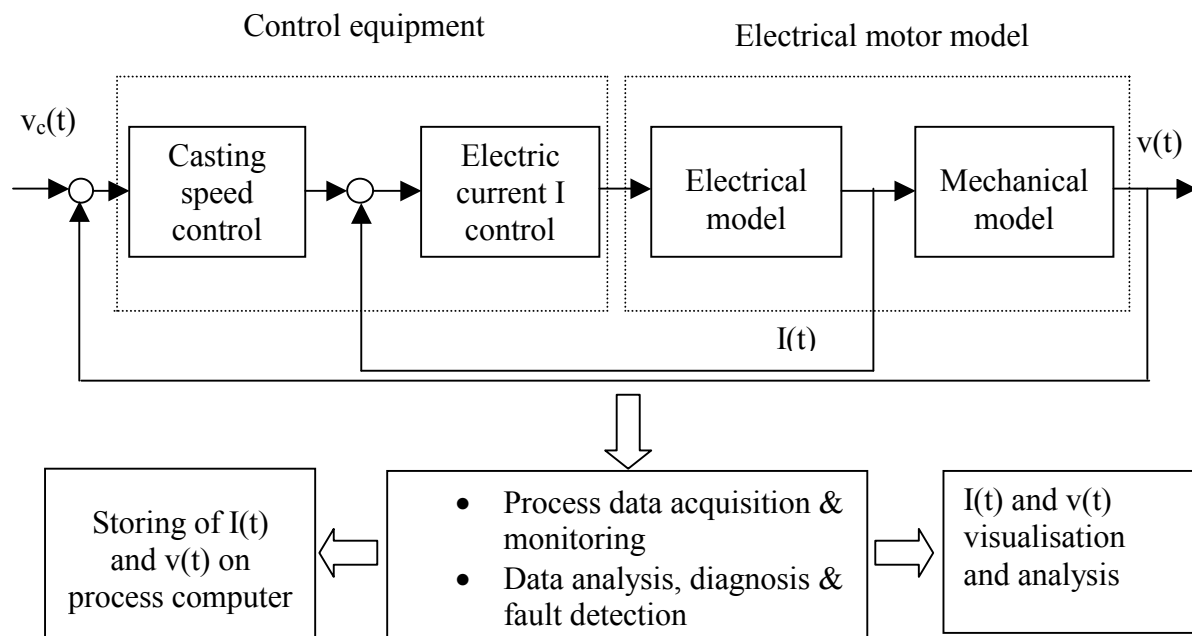


Fig. 6.6: Principle of closed loop control, process monitoring and diagnosis

Both inputs and outputs have been connected to the data acquisition system interfaces using a real-time software (Labview, National Instrument) and the results are given in **Fig. 6.7**.

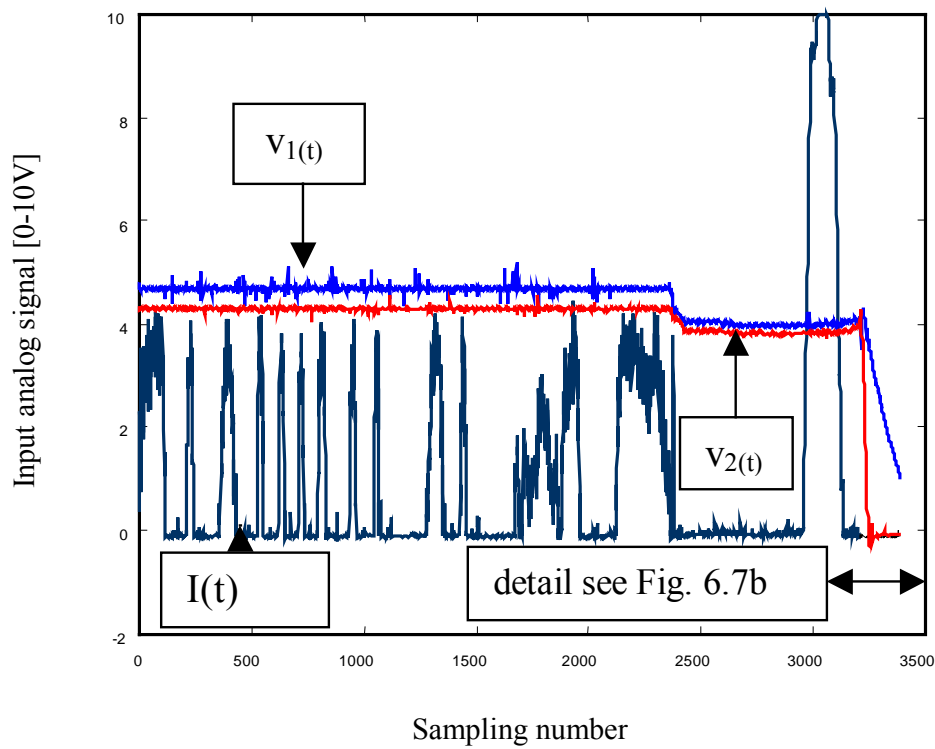


Fig. 6.7a: Casting speed and current data acquisition

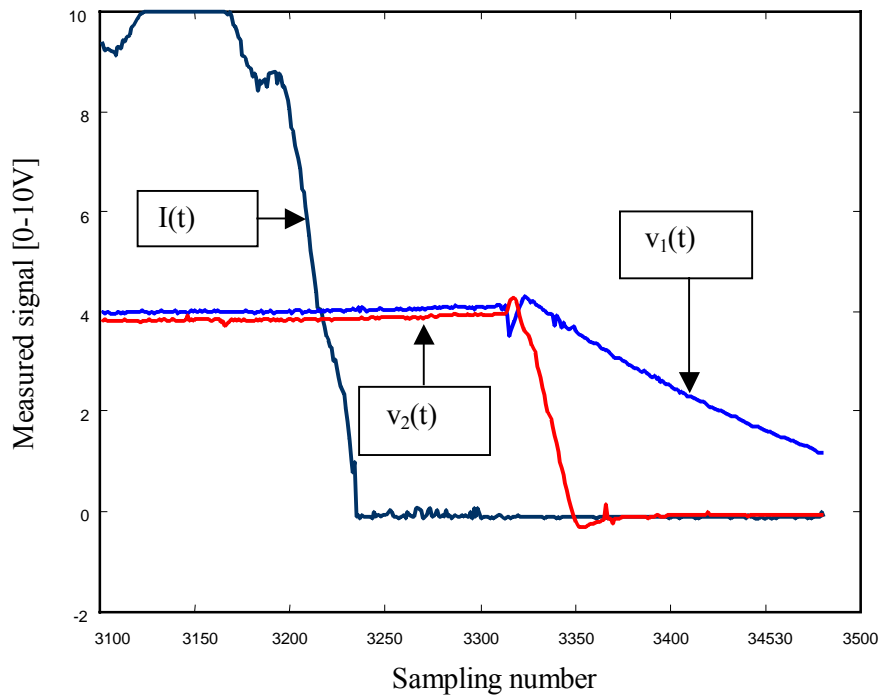


Fig. 6.7b: Detail of monitored data of Fig. 6.7a

Analysis of data shows that the motor current is cancelled at the moment when the motor must have a maximum power. This observation has been used to verify the power bloc; the defect is detected on the electrical power unit. After repair, the casting process has continued to operate normally without strand defects. The results are given in **Fig. 6.8**.

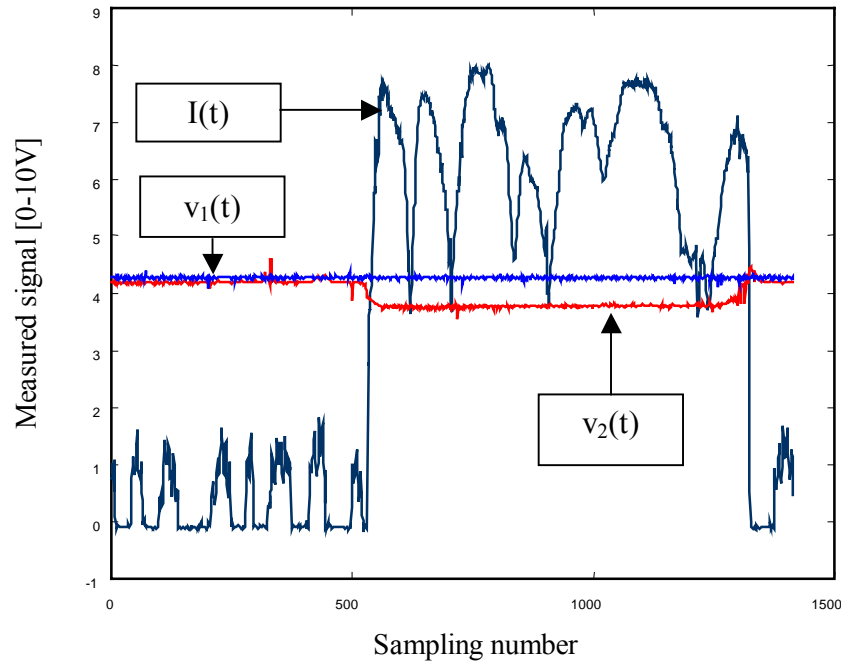


Fig. 6.8: Monitored parameters after defect elimination

### 6.2.3 Fault detection and modelling

Data acquisition from the process is used as a data bank to model the faults related to the electrical power unit. The objective of the modelling is to detect and predict a similar defect which permits the quick detection of the origin and reduces the reject production. The desired alarm model equation is:

$$\text{Alarm} = NN[I(k), I(k-1), v_1(k), v_1(k-1)] \quad (6.2)$$

The overall structure of the fault detection is given in **Fig. 6.9**. This is a widely used multilayer feed forward network in which the measured process parameters are used as inputs. Firstly, a feed forward NN identifies the alarm model in which the network weights are initialised by arbitrary values. These values are then used to compute the NN output. The error between computed and real output is propagated by the learning rate and the network is

designed to generate appropriate weights in order to reduce the error. After convergence, the obtained NN weights are used to compute the alarm output.

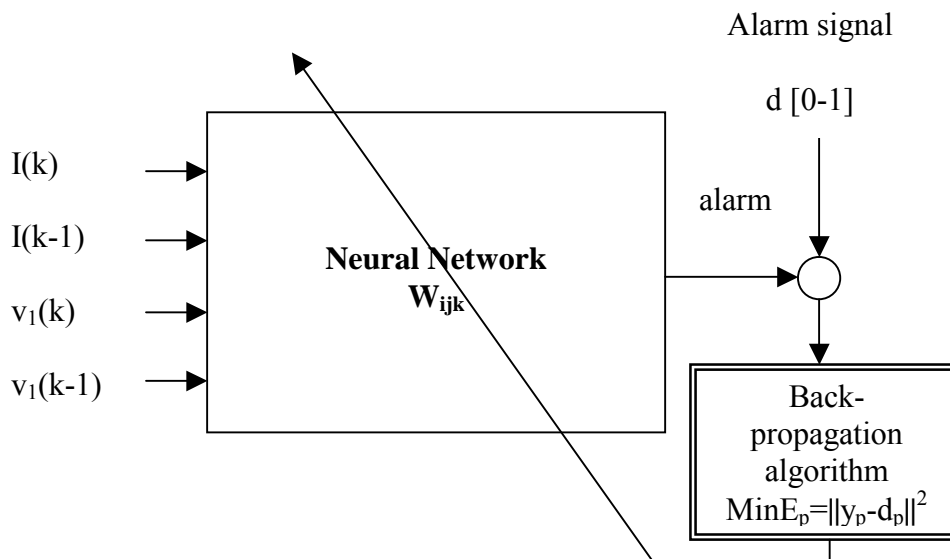


Fig. 6.9: Overall structure of learning and modelling of the alarm model

For each sampling number, the network input is  $[I(k), I(k-1), v_1(k), v_1(k-1)]$  and the output is an alarm signal  $d [0 -1]$ . **Fig. 6.10** gives the learning convergence of the fault detection model.

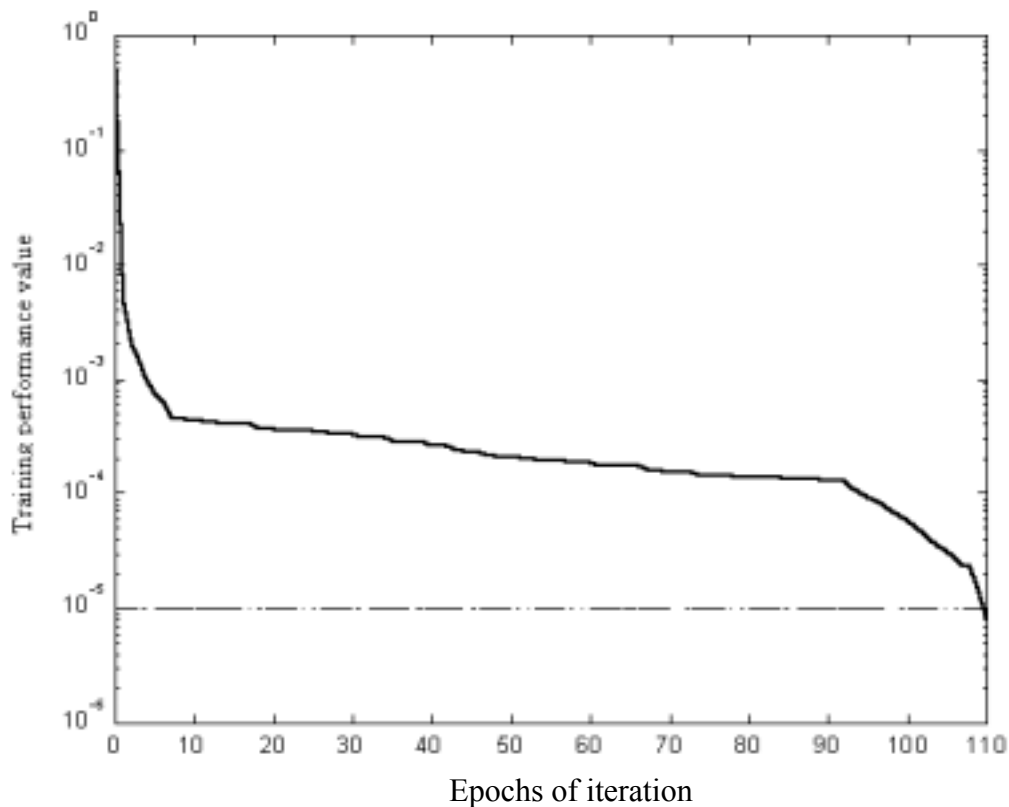


Fig. 6.10: Learning convergence

## 6.2.4 Application

The objective of the fault detection model is to predict a future defect by releasing an alarm. The alarm signal is equal to zero (0) at normal operating conditions and is equal to one (1) when there is a defect. The neural network modelling and identification of the considered defect are achieved by an off-line learning mode. The neural network model fault detection was implemented on the process computer using graphic programming software under a Windows NT operating system. Results of on-line application of this model are given in **Figs. 6.11, 6.12 and 6.13**.

## 6.2.5 Results

The learning processes of neural networks were achieved using an off-line training by the process defect database. The model convergence given in **Fig. 6.8** was obtained in 110 epochs. The obtained neural network weights were used to detect the faults related to the on-line thyristor defects. Two types of model input signals were applied based on normal operating conditions and process defects. **Figs. 6.11 and 6.12** show two cases for the model capability to detect a fault using the developed model. Two tests have been realised (**Figs. 6.11 and 6.12**) for the case of defect presence. Alarms are activated by passing from 0 to 1 at the sampling number of 580 and 3000 respectively (**Figs. 6.11b and 6.12b**). **Fig. 6.13** shows the normal operating conditions and the alarm level which equals approximately zero (of the order of  $10^{-4}$ ). This modelling and prediction technique allows for the detection of the casting speed synchronisation problem that strongly affects the strand surface quality.

A NN model has been developed for quality monitoring on the basis of breakout propagation in the mould. The obtained results confirm the importance of NN as a tool for quality control, fault diagnosis and investigation.

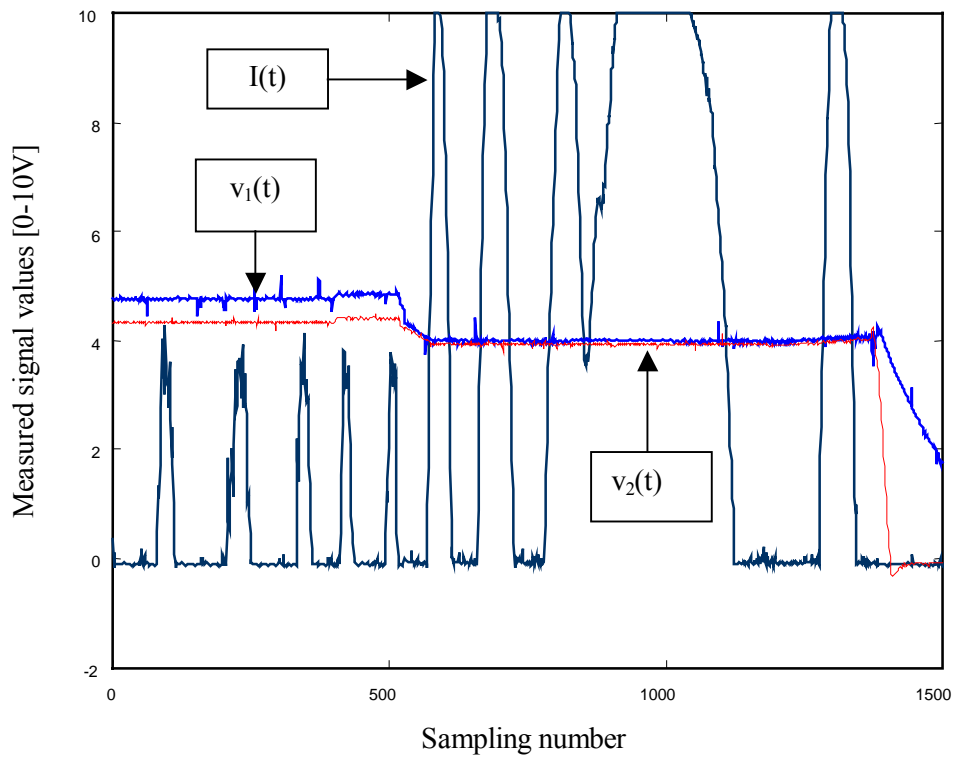
**Example I**

Fig. 6.11a: Dynamical motor parameters

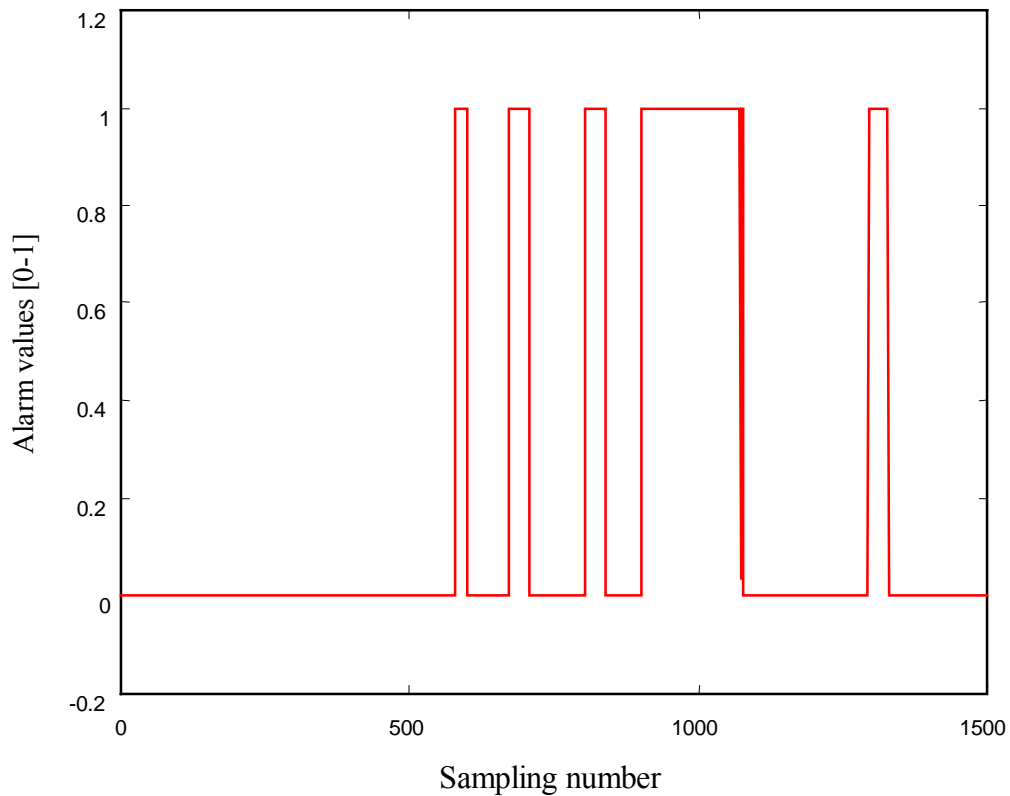


Fig. 6.11b: Alarm signal evolution

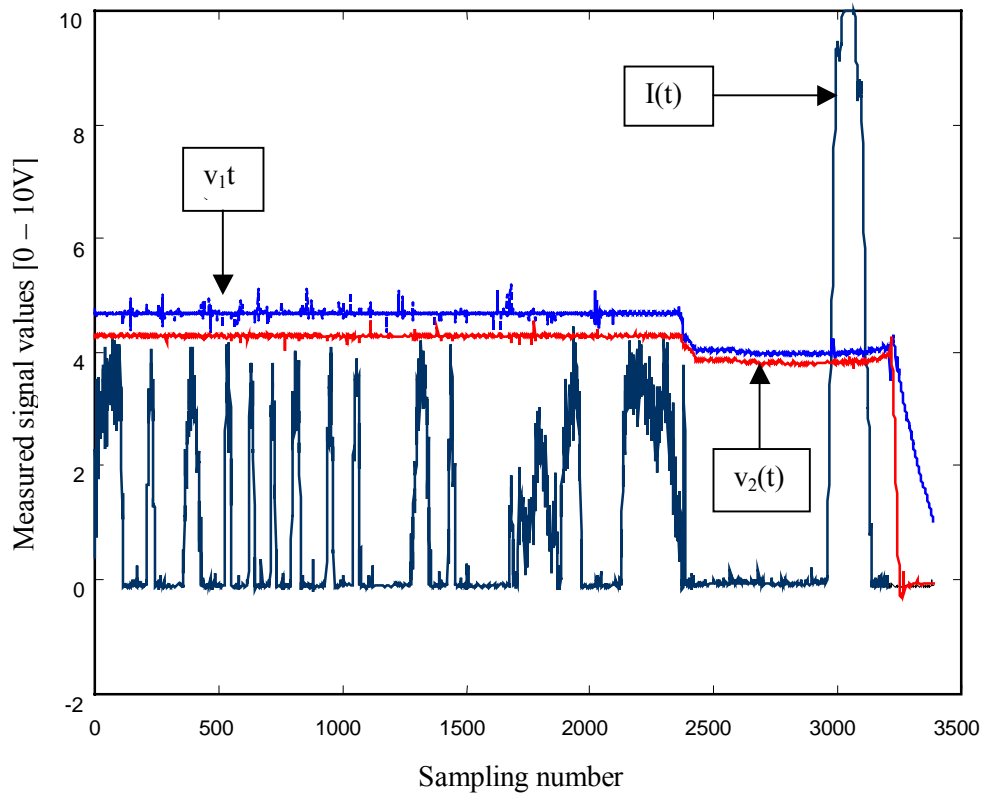
**Example II**

Fig. 6.12a: Dynamical motor parameters

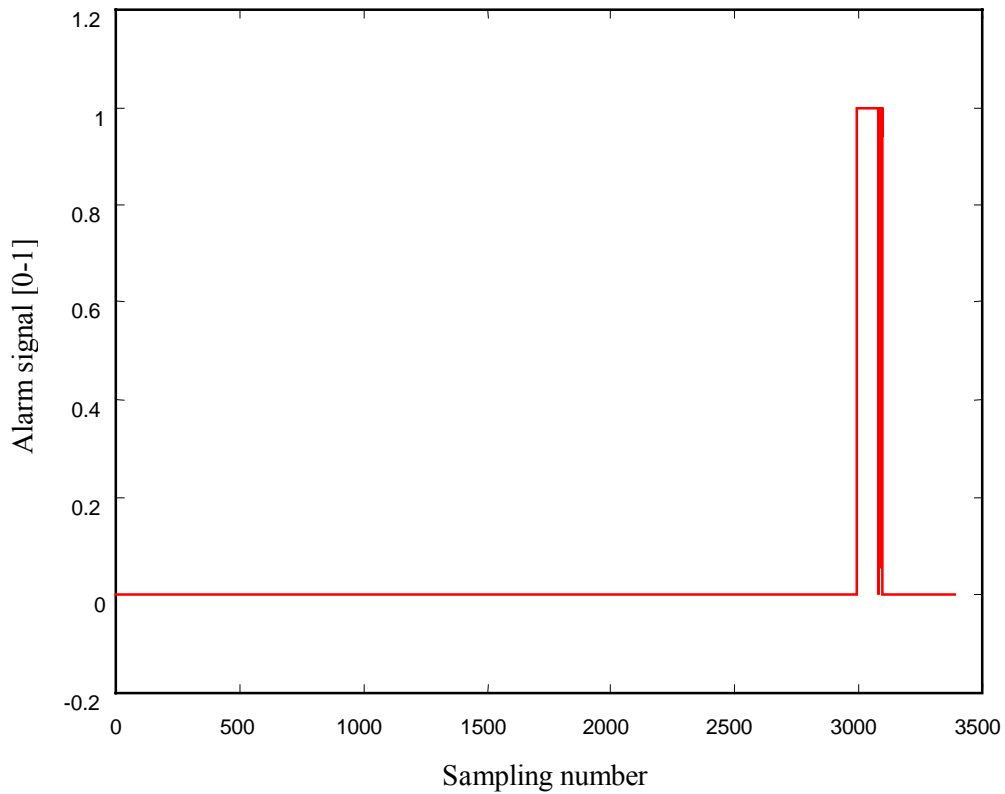


Fig. 6.12b: Alarm signal evolution

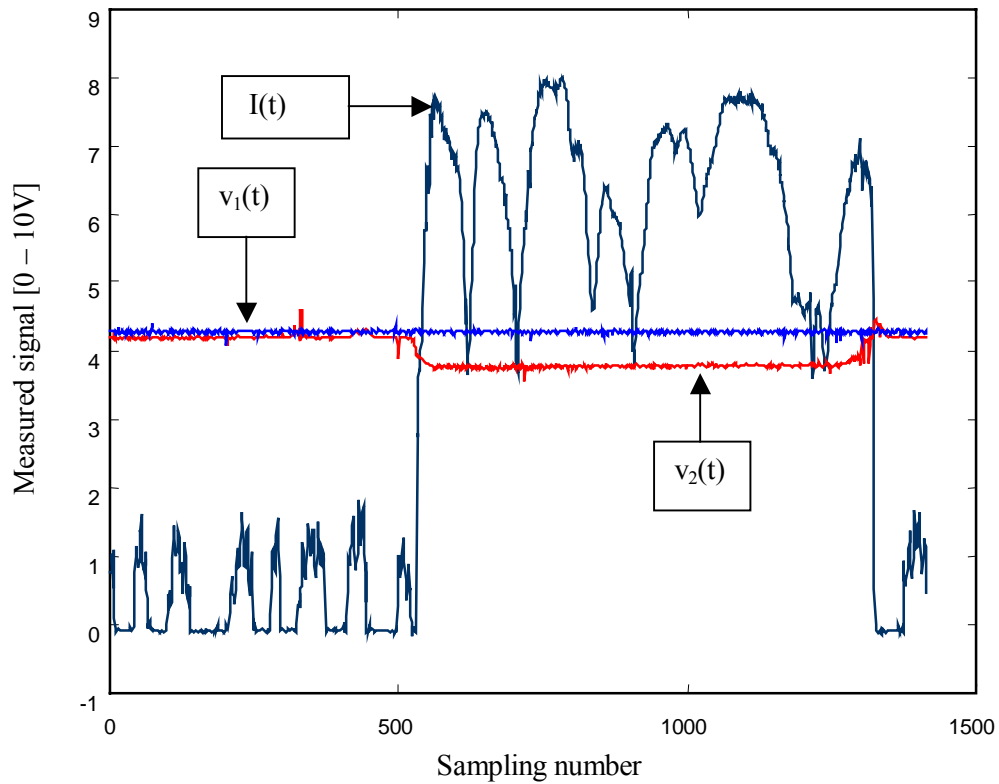
**Example III**

Fig. 6.13a: Dynamical motor parameters

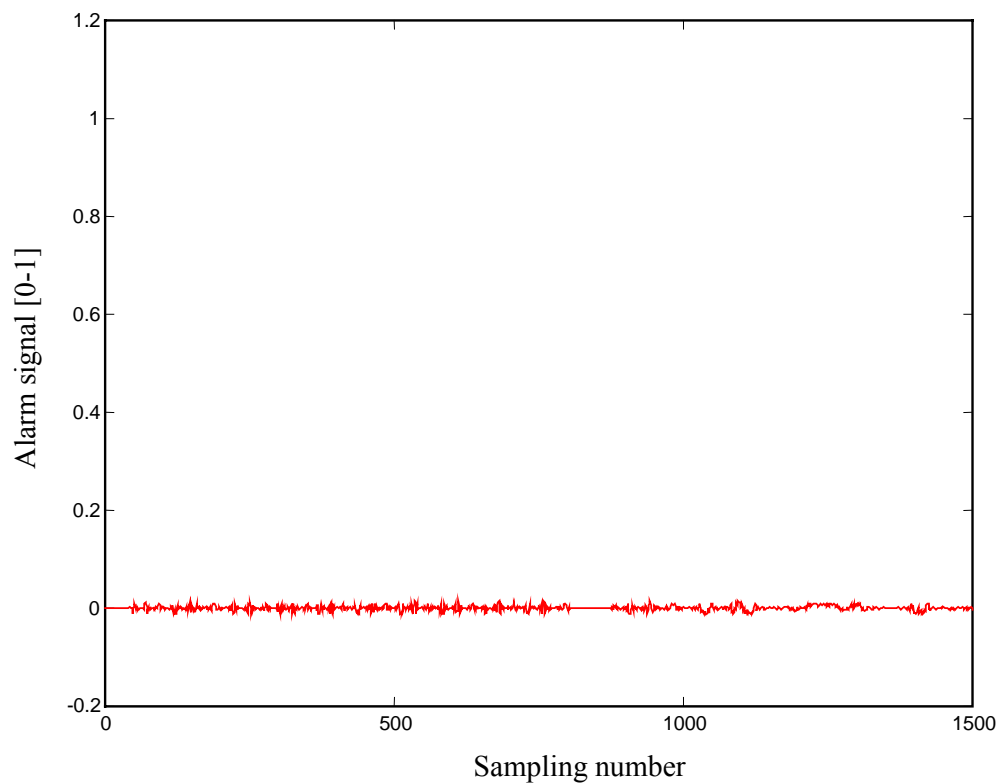


Fig. 6.13b: Alarm signal evolution



## 7 CONCLUSION AND OUTLOOK

In this thesis work, a contribution to process and quality optimisation in ladle refining and continuous casting of steel has been developed. The advanced tools based on neural networks modelling have been applied to different process stages in steel production. Particular attention has been given to the development of a reliable breakout prediction system in continuous casting. The ability of this new system has been tested using breakout alarm databases from EKO STAHL, Eisenhüttenstadt, Germany.

The NN breakout system based on the instrumentation of the mould by a matrix of thermocouples using a model of prediction by NN was developed, implemented and tested. The training of the model and tests of detection were carried out using real and false breakout data. In the case of real alarm, the results do not detect the presence of false alarms. The developed algorithm detected the dynamic behaviour of temperature profiles having generated real breakouts. In the case of false alarms, the developed model does not detect false breakouts.

The ability of the NN to detect complex processes by noise signals makes these a valuable tool in almost all fault detections and helps in increasing the production quality standards. This work is an example for a NN based system which has been acquired using earlier data and can improve continuously by learning from experiences gathered during on-line operation. The capability of the neural breakout detection system can be summarised by the following items:

- Reliable detection of stickers in the continuous casting process
- Avoidance of the misclassification of conventional alarm systems
- Invariance with respect to variations in steel quality
- Robustness based on the variations of casting conditions
- Robustness on the basis of bath level and steel temperature variations

The results of the off-line evaluation have been fully confirmed. All real alarms have been detected by both systems. However, the alarms from the NN detection system occur earlier compared to those of the conventional system.

Further developments seem to be necessary for a better optimisation of the structure and parameters of the model.

In chapter 3, a NN predictor was designed and tested through simulation and practice. The previous NN model based on the back-propagation learning algorithm has a good prediction performance. Because the casting cycle is long, the learning process is easily achieved between the actual and the next charge. The prediction ability using NN improves the prediction capacity. Large-scale industrial tests, on-line implementation in steelmaking and the development of a software package are currently being investigated at SIDER Group Algeria. In specific situations of steel refining processes, where there are problems related to the timing and the chemical analysis equipment, this model can be used as a soft sensor to predict the final chemical composition without waiting for laboratory analysis results. This approach can be expanded without difficulties to other typical processes.

A NN closed loop control scheme of heat transfer in the continuous casting process was designed and tested through simulation in chapter 5. The neural network controller based on an inverse model seems to have a good control performance for changes of heat transfer parameters, casting speed variations and set point changes. The changes in strand surface temperature are smaller than in conventional control where there exists an important tracking error. Coupling effects are also cancelled. The implementation of on-line control in the continuous casting process is currently being investigated. Feedback control requires a continuous measurement of surface temperature in the cooling zones. This constitutes a disadvantage. In practice it is recommended that this approach should be used only in specific situations with regard to sensitive steel grades.

In chapter 6, systems for fault diagnosis, detection of cracks and repair were realised in the continuous casting process using real-time monitoring of the major process parameters. The real-time monitoring of the process parameters is an important tool for detecting and repair because it reduces the defect searching time. Fault databases were used to develop a fault model that predicts future defects by the electrical power unit using dynamics of the rotation system parameters such as rolling speed and electrical current. This model is actually implemented on the process computer in the continuous casting process.

The NN quality monitoring is a non-linear classifier which is obtained by a combination of relevant variables that have been considered by the breakout detection system. Breakout alarm monitoring using the NN model is an important tool to quality classification. It can be used to guide quality inspection services.

The breakout alarm management and quality monitoring remains open for other developments such as neuro-fuzzy application to a number of alarms and breakout defects.

The application of this technology for the prediction of other types of defects will be the subject of future research and development work.

A contribution to the improvement of main processes in steelmaking has been achieved. The scientific importance given through the NN model implementation and on-line control represents a highlight. Particular importance has been given to the breakout detection system which is of great economical impact. Mathematical modelling does not completely solve problems in steelmaking but in the majority of cases it leads to an improvement. Parallel process computing approaches can be used as a means for future development and application of mathematical modelling in the main processes of the steel industry.

## 8 REFERENCES

- [1] K.Mörwald et al., Dynacs: Cooling system—features and operational results, *Ironmaking and Steelmaking*, 25(4), pp 323-327, 1998.
- [2] M<sup>me</sup>Etiene, Reflexion sur le contrôle du refroidissement secondaire des installations de coulée continue, rapport de la commission coulée continue, Centre de Recherche Métallurgique de Liège, 1977.
- [3] M<sup>me</sup>Etiene, Contrôle métallurgique d'une machine de coulée continue à brames, Rapport final convention CCE/Centre de Recherche Métallurgique de Liège, Belgique Nr 7210, CA/204, 1977.
- [4] J.P.Birat, Modelling and process control in steel industry, *Révue de Métallurgie, CIT* (11), pp 1348-1367, 1997.
- [5] A.J.Morris and E.B.Martin, Neural networks—Panacea or pragmatic solution, European Commission for Technical Steel Research, ECSC Workshop, Proceedings of Application of Artificial Neural Network Systems in the Steel Industry, Brussels 22-23 January, pp 9-41, 1998.
- [6] M.Sanarico, Neural networks: The ideal and the commercially available tools, European Commission for Technical Steel Research, ECSC Workshop, Proceedings of Application of Artificial Neural Network Systems in the Steel Industry, Brussels 22-23 January, pp 45-50, 1998.
- [7] J.Frigière, L.Bertrand, M.Chouvet, M.Lallier and R.Perisse, The state of the art of neural network application in the iron and steel industry outside of Europe, European Commission for Technical Steel Research, ECSC Workshop, Proceedings of Application of Artificial Neural Network Systems in the Steel Industry, Brussels 22-23 January, pp 53-62, 1998.
- [8] M.Falzetti, J.Mochon and S.Kumar, Results and perspectives of using artificial intelligence techniques in blast furnaces: The FANCIM project, European Commission for Technical Steel Research, ECSC Workshop, Proceedings of Application of Artificial Neural Network Systems in the Steel Industry, Brussels 22-23 January, pp 95-104, 1998.
- [9] K.Harste et al., Optimisation of casting and cooling strategies in continuous casting with help of mathematical modelling, 10<sup>th</sup> PTD Conference Toronto Canada, (10), pp 305-316, 1992.
- [10] H.Whittker, M.Hartwig, M.Poschmann and A.Seeliger, The use of neural networks in

- BOS Process Modelling, European Commission for Technical Steel Research, ECSC Workshop, Proceedings of Application of Artificial Neural Network Systems in the Steel Industry, Brussels 22-23 January, pp 135-144, 1998.
- [11] M.Hormel and M.Schwartz, Breakout prediction in continuous casting by artificial neural networks, European Commission for Technical Steel Research, ECSC Workshop, Proceedings of Application of Artificial Neural Network Systems in the Steel Industry, Brussels 22-23 January, pp159-167, 1998.
- [12] S.Li, X.Gao, J.Chai and X.Wang, Neural network techniques and its applications in ladle furnace burden, Proceedings of IFAC Automation in Steel Industry: Current Practice and Future Developments, pp 165-168, 1997.
- [13] J.Bast und S.Bouhouche, Mathematische Modellierung einer Strangießanlage, Freiburger Forschungshefte, Automatisierung in der Montanindustrie Freiberg Germany A839, pp 37-50, 1997.
- [14] C.Barlocco, Projet d'un système d'automatisation du refroidissement secondaire en coulée continue, *Révue de Métallurgie, CIT* (12), pp 947-951, 1983.
- [15] B.Stefano et al., Computer control and optimisation of secondary cooling during continuous casting, *Iron and Steel Engineer* (11), pp 21-26, 1986.
- [16] K.Harste et al., Process Control and strand condition monitoring at Dillinger Hüttenwerke, *Révue de Métallurgie, CIT* (4), pp 1241-1247, 1996.
- [17] B.Holger, Computersimulation thermischer und mechanischer Vorgänge beim Brammenstranggießen von Stahl, Dissertation Dr.-Ing Nr 94.10186/3, TU Bergakademie Freiberg 1994.
- [18] K.H. Spitzer et al., Mathematical model for thermal tracking and on-line control in continuous casting, *ISIJ International*, 32 (7), pp 848-856, 1992.
- [19] M.Sergio, S.E.Alice and B.Bopaya, Neural predictive quality model for slip casting using categorical metrics, Proceedings of the 2<sup>nd</sup> Industrial Engineering Research Conference, pp 265-269, 1993.
- [20] F.Angela and L.Marcel, Quality control in die casting with neural networks, Proceedings of 1<sup>st</sup> International Symposium on Neuro-Fuzzy Systems, pp 1-7, 1996.
- [21] E.Laitinen. and P.Neittaanmaki, On numerical simulation of the problem connected with the control of the secondary cooling in the continuous casting process, *CTAT* 14(3), pp 284-305, 1988.
- [22] M.Larrecq, C.Saguez et M.Wanin, Modèle mathématique de la solidification en coulée

- continue tenant compte de la convection à l'interface solide-liquide, *Révue de Métallurgie, CIT* (6), pp 337-352, 1978.
- [23] B.Lally, L.Biegler and H.Henein, Finite difference heat transfer modelling for continuous casting, *Metallurgical Transactions B21* (4), pp 761-770, 1990.
- [24] S.Louhenkilpi, E.Laitinen and R.Nieminen, Real-time simulation of heat transfer in continuous casting, *Metallurgical Transactions B* (24), pp 685-693, 1993.
- [25] I.F.Taylor, G.J.Thornton and R.J.Batterham, Process control models for real-time applications, *Ironmaking and Steelmaking* 17, (6), pp 438-442, 1990
- [26] G.Brunnbauer, B.Rummer and J.Marhart, The fully automatic blast furnace only a vision, *Révue de Métallurgie*, (6), pp 542-552, 2001.
- [27] R.Capotosti, F.Macci and A.Spaccarotella, Computerised surface quality prediction in the continuous casting of stainless steel slabs, *AISE Spring Convention, Salt Lake City*, pp 61 – 71, 1995.
- [28] D.Lee, J.S.Lee and T.Kang, Adaptive fuzzy control of the molten steel level in a strip casting process, *Control Engineering Practices*, 4, (11), pp 1511-1520, 1996.
- [29] L.Brimacombe, C.Jackson and N.Schofield, Artificial intelligence expert system for steelworks pollution control, *Révue de Métallurgie, CIT* (1), pp 111-116, 2001.
- [30] C.Harris, M.Brown, K.M.Bossley, D.J.Mills and F.Ming, Advances in neuro-fuzzy algorithms for real-time modelling and control, *Engineering Application of Artificial Intelligence*, 9, (1), pp 1-16, 1996.
- [31] K.E.Blazek and I.G.Saucedo, Recovery of sticker type breakouts, *Proceedings of Steelmaking Conference*, pp 99-107, 1989.
- [32] J.H.Zietsman, S.Kumar, J.A.Meech, I.V.Samarasekera and J.K.Brimacombe, Taper design in continuous billet casting using neural networks, *Ironmaking and Steelmaking* 25 (6), pp 476-483, 1998.
- [33] P.Bellomo, M.Milone, A.Spaccarotella, F.Vicino and M.Sanarico, Stainless steel slab surface quality prediction by means of artificial neural networks, *European Commission for Technical Steel Research, ECSC Workshop, Proceedings of Application of Artificial Neural Network Systems in the Steel Industry, Brussels 22-23 January*, pp 181-193, 1998.
- [34] L.G.Lock, A.R.Mc.Namara, K.C.The, H.M.Lie, B.J.Orenstein and D.J.H.Brown, Rapid prototyping tools for real-time expert systems in the steel industry, *ISIJ International*, 30, pp 90-97, 1990.

- [35] N.Link and N.Holzkhecht, Quality prediction by data based methods, European Commission for Technical Steel Research, ECSC Workshop, Proceedings of Application of Artificial Neural Network Systems in the Steel Industry, Brussels 22-23 January, pp 171-178, 1998.
- [36] N.Chakraborti and A.Mukherjee, Optimisation of continuous casting mould parameters using genetic algorithms and other allied techniques, *Ironmaking and Steelmaking*, 27, (3), pp 243-247, 2000
- [37] S.Bouhouche, M.S.Boucherit and M.Lahreche, Improvement of breakout detection system in continuous casting process using neural networks, *IEEE Proceedings on Advanced Process Control Applications for Industry Workshop*, Vancouver, Canada, pp 53-63, 2001, (Site Internet [www.ieee-ias.org/apc2001](http://www.ieee-ias.org/apc2001)).
- [38] N.Ramaseder and J.Heiss, VAI-CON<sup>R</sup> Temp: Continuous temperature monitoring in metallurgical vessels, *Révue de Métallurgie, CIT* (6), pp 562-569, 2001.
- [39] P.N.Hewih, A.Robson, A.S.Normanton, N.S.Hunter and A.Scholes, Continuous casting development at British steel, *Révue de Métallurgie, CIT* (6), pp 765-776, 1998.
- [40] H. Kominami et al., Neural networks system for breakout prediction in continuous casting process, *Nippon Steel Technical Report*, (49), pp 34-38, 1991.
- [41] S.B.Singh, H.K.D.H.Bhadeshia, D.S.C.Mackay, H.Creyand and I.Martin, Neural network analysis of steel plate processing, *Ironmaking and Steelmaking*, 25, (5), pp 355-365, 1998.
- [42] P.Hemy, R.Smylie and C.Srinivasan, Analysing casting problem by the on-line monitoring of continuous casting mold temperatures, *JOM-e*, 2002, [www.ums.tms.org/pubs/journals/JOM/021/Hemy/Hemy-0201.html](http://www.ums.tms.org/pubs/journals/JOM/021/Hemy/Hemy-0201.html)
- [43] J.T.Niu, L.J.Sun and P.Karjalainen, A neural network-based model for prediction of hot-rolling austenite grain size and flow stress in microalloy steel, *Acta Metallurgica Sinica (English letters)*, 13, (2), pp 521-530, 2000.
- [44] F.H.R.Sesselmann, Improving EAF energy utilisation with electrode controllers based on neural networks, *Proceedings of IFAC Automation in Mining, Mineral and Metal Processing*, pp 61-67, 1998.
- [45] S.Z.Suo, L.Yuon and S.Kang, The AGC-ASC synthetic artificial neural networks controllers, *Proceedings of IFAC Automation in Mining, Mineral and Metal Processing*, pp 137-142, 1998.

- [46] N.Bhat, P.Minderman and P.Mc.Avoy, Use of neural nets for modelling of chemical process systems, IFAC Symposium, pp 21-23, 1989.
- [47] Di.Psaltis, A.Sideris and A.Yamamura, A multilayered neural network controller, IEEE Control System Magazine, pp 17-21, 1988.
- [48] M.Norgaard, O.Ravn, N.K.Poulsen and L.K.Hansen, Neural networks for modelling and control of dynamic systems, Springer, ISBN 1-85233-227, 2000.
- [49] M.Jansen, E.Broese, B.Feldkeller, O.Gramckown, T.proppe, M.Schlang and G.Sorgel, Application of neural networks to process control in steel industry, Proceedings of IFAC Automation in Mining, Mineral and Metal Processing, pp 177-182, 1998.
- [50] M.Waller and H.Saxén, Time-varying Fir-models for short-term prediction of pig silicon content, Proceedings of IFAC Automation in Mining, Mineral and Metal Processing, pp 227-232, 1998.
- [51] M.Hadjiski, I.Kalaykov and S.Mollov, Neural network modelling and control of parameter depending metallurgical plants, Proceedings of IFAC Automation in Mining, Mineral and Metal Processing, pp 375-380, 1998.
- [52] G.C.Goodwin and R.Middleron, Advanced control applications in the steel industry, Proceedings of IFAC Automation in Steel Industry: Current Practice and Future Developments, pp 13-18, 1997.
- [53] Y.I.Kim, K.C.Moon, B.S.Kang, C.Han and K.S.Chang, Application of Neural network to supervisory control of reheating furnace in steel industry, Proceedings of IFAC Automation in Steel Industry: Current Practice and Future Developments, pp 33-38, 1997.
- [54] H.Ingason and G.R.Jonsson, On the control of silicon ratio in ferrosilicon production, Proceedings of IFAC Automation in Steel Industry: Current Practice and Future Developments, pp 73-78, 1997.
- [55] Y.Kueon and S.Y.Yoo, Mold level control in continuous caster via non-linear control technique, Proceedings of IFAC Automation in Steel Industry: Current Practice and Future Developments, pp 169-173, 1997.
- [56] X.G.Shujiangli, T.Chai and X.Wang, Intelligent compound control of direct current electric arc furnace, Proceedings of IFAC Automation in Steel Industry: Current Practice and Future Developments, pp 135-140, 1997.
- [57] J.S.Choi, H.Kim and Y.J.Moon, Identification and adaptive control of dynamic systems using self-organised distributed networks, Proceedings of IFAC Automation in Steel Industry: Current Practice and Future Developments, pp 91-96, 1997.



- [58] D.Y.Seok and J.S.Lee, Adaptive inverse control for non-linear plants, Proceedings of IFAC Automation in Steel Industry: Current Practice and Future Developments, pp 199-204, 1997.
- [59] S.Johnstone and A.G.Taylor, Application of multivariate statistical methods to blast furnace hearth temperatures, European Commission for Technical Steel Research, ECSC Workshop, Proceedings of Application of Artificial Neural Network Systems in the Steel Industry, Brussels 22-23 January, pp 69-91, 1998.
- [60] K.S.Yoon and M.H.Lee, On the design of self-tuning controller using generalised predictive control, Proceedings of IFAC Automation in Steel Industry: Current Practice and Future Developments, pp 85-90, 1997.
- [61] M.L.Goc and C.C.Thirion, The SACHEM experience on artificial neural networks application, European Commission for Technical Steel Research, ECSC Workshop, Proceedings of Application of Artificial Neural Network Systems in the Steel Industry, Brussels 22-23 January, pp107-131, 1998.
- [62] C.D.I.Massimo, G.A.Montague, M.J.Willis, M.T.Tham and A.J.Morris, Towards improved penicillin fermentation via artificial neural networks, Computer in Chemical Engineering, 16, (4), pp 283-291, 1992.
- [63] S.Kumar et al., Development of intelligent mould for on-line detection defects in steel billets, Ironmaking and Steelmaking, 26(4), pp 269-284, 1999.
- [64] M.Konishi, Development of intelligent processes in iron and steel industry, Metal and Technology (Japan), 63, (2), pp 11-15, 1993.
- [65] J.D.Madill, Application of mould thermal monitoring to Avesta Sheffield's SMACC slab caster, Ironmaking and Steelmaking, 23, (3), pp 228-234, 1996.
- [66] S.Bouhouche, M.Lahreche and J.Bast, Mould thermal monitoring and control in continuous casting process, Proceedings of 6<sup>th</sup> Arab Congress on Iron and Steel Industry, Alexandria-Egypt, October 2000.
- [67] P.Albertos, J.Picó, J.L.Nnavado and A.Crespo, Some issues on artificial intelligence techniques in real-time process control, Proceedings of IFAC Automation in Steel Industry: Current Practice and Future Developments, pp 1-12, 1997.
- [68] A.Heinrich and S.Roman, Latest development for control of high quality processed steel strips, Proceedings of IFAC Automation in Mining, Mineral and Metal Processing, pp 393-398, 1998.
- [69] C.A.M.Pinheiro, I.V.S.Samarasekera, J.K.Brimacombe, B.Howes and O.Gussias, Mould

- heat transfer and continuously cast billet quality with mould flux lubrication Part2: Quality issues, *Ironmaking Steelmaking*, 27, (2), pp 144-159, 2000
- [70] J.Lunze, Process supervision by means of qualitative models, *Proceedings of IFAC Automation in Mining, Mineral and Metal Processing*, pp 105-118, 1998.
- [71] D.Meyer and S.Heinkel, An information system for quality data in industrial production processes, *Proceedings of IFAC Automation in Mining, Mineral and Metal Processing*, pp 165-169, 1998.
- [72] S.Burkhardt and U.Stein, Automatic surface inspection and quality control-A survey, *Proceedings of IFAC Automation in Mining, Mineral and Metal Processing*, pp 183-186, 1998.
- [73] T.Kim and S.R.T.Kumara, Boundary defect recognition using neural networks, *International Journal of Production Research*, 35, (9), pp 2397-2412, 1997.
- [74] W.R.Irving, Online quality control for continuously cast semis, *Ironmaking and Steelmaking*, 17, (3), pp 197-202; 1990
- [75] D.Widlund, A.Medvedev and R.Gyllenram, Towards model-based closed-loop control of the basic oxygen steelmaking process, *Proceedings of IFAC Automation in Mining, Mineral and Metal Processing*, pp 69-74, 1998.
- [76] O.Reisch, R.Weller and T.Pirron, TOPAZ-Decentralised cooperative production management, *Proceedings of IFAC Automation in Mining, Mineral and Metal Processing*, pp 81-85, 1998.
- [77] H.Albrecht and B.Peters, Communication in process control, *Proceedings of IFAC Automation in Mining, Mineral and Metal Processing*, pp 281-286, 1998.
- [78] B.lodin, T.K.Lovborg-Laustsen, A.Kjaer, J.weiss, H.Preissl and P.Juza, Slab caster automation upgrade at Dansteel Denmark, *Révue de Métallurgie, CIT* (6), pp 753-761, 2000.
- [79] G.Sorgrl, T.Poppe and M.schlang, Real-time control with neural networks in steel processing, European Commission for Technical Steel Research, ECSC Workshop, *Proceedings of Application of Artificial Neural Network Systems in the Steel Industry*, Brussels 22-23 January, pp 209-225, 1998.
- [80] C.Foulard, S.Gentil and J.P.Sandraz, *Commande et régulation par ordinateur numérique* Cinquième Edition Eyrolles, 1987.
- [81] M.Najim, *Identification et modélisation en traitement de signal*, Edition Masson, 1988.
- [82] M.Cabarrere, J.P.Krief et B.Gimonet, *Le filtrage et ses applications*, Cepaques Editions, 1982.

- [83] K.Najim, *Commande adaptative des procédés industriels*, Edition Masson, 1982.
- [84] I.D.Landau et al., *Commande adaptative aspects théoriques et pratiques*, Edition Masson, 1986.
- [85] L.Praly, *Introduction à la théorie de la commande adaptative des systèmes linéaires*, Ecole Supérieure des Mines de Paris, Centre Automatique et Systèmes, Février 1992.
- [86] K.Najim et G.Murat, *Optimisation et commande en génie des procédés*, Edition Masson, 1987.
- [87] C.A.Bazzo, *Le filtrage optimal et ces applications aux problèmes de poursuite*, Tome 2, Edition Lavoisier, 1983
- [88] S.Chen and S.A.Billing, *Neural networks for non-linear dynamic system modelling and identification*, *International Journal of Control* 56 (2), pp 319-346, 1992.
- [89] S.Weerasooriya and M.A.Sharkawi, *Identification and Control of a DC Motor using back-propagation neural networks*, *IEEE Transactions On Energy Conversion* 6(4), pp 663-670, 1991.
- [90] E.Yurio et al., *Feedforward control of thermal plants using neural networks*, *Research Reports on Information Science and Electrical Engineering of Kyushu University*, 03 (1), pp 13-21, 1998.
- [91] A.P.Loh, K.O.Looi and K.F.Fong, *Neural network modelling and control strategies for a pH process*, *Journal of Process Control*, 15 (6), pp 355-362, 1995.
- [92] W.Zhenni, D.Christine, T.Ming and J.A.Morris, *A procedure for determining the topology of multilayer feedforward neural networks*, *Neural Networks*, 7, (2), pp 291-300, 1994.
- [93] D.Phram and X.Liu, *State space identification of dynamic systems using neural networks*, *Engineering Application in Artificial Intelligence*, (3), pp 198-203, 1990.
- [94] L.Jin, P.N.Nikiforuk and M.M.Gupta, *Direct adaptive output tracking control using multilayered neural networks*, *IEE, Control Theory Application*, (140), pp 393-398, 1993.
- [95] K.S.Narendra and K.Parthasarathy, *Identification and control of dynamical systems using neural networks*, *IEEE Trans Neural Networks*, 1, (1), pp 4-27, 1990
- [96] H.B.Ronald, L.R.Timothy and F.Xin, *On identification of partially known dynamic non-linear systems with neural networks*, *Proceedings of the International Symposium on Intelligent Control*, pp 499-504, 1993.

- [97] J.Zhang, Developing robust neural network models by using both dynamic and static process operating data, *Industrial Engineering Research*, (40), pp 234-241, 2001.
- [98] J.P.Pelletier, *Techniques numériques appliquées au calcul scientifique*, Edition Masson, 1982.
- [99] J.Legaras, *Algorithmes et programmes d'optimisation non linéaire avec contraintes: Application au contrôle optimal*, Edition Masson, 1982.
- [100] S.Kumpati, N.Arenda and K.Parthasarathy, Identification and control of dynamical systems using neural networks, *IEEE Trans on Neural Networks*, 1, (1), pp 4-27, 1990.
- [101] J.Leonard and M.A.Kramer, Improvement of the back-propagation algorithm for training neural networks,, *Computer Chemical Engineering*, 14, (3), pp 337-341, 1990.
- [102] Y.Liguni, H.Sakai and H.Tokumaru, Real-time learning algorithm for multilayered neural network based on the extended Kalman filter, *IEEE Trans on Signal Processing*, 40, (4), pp 959-966, 1992.
- [103] M.S.Ahmed and I.A.Tasadduq, Neural net controller for non-linear plants: Design approach through linearisation, *IEE, Control Theory Application*, 141, (5), pp 315-322, 1994.
- [104] J.Abonyi, R.Babuska, M.Y.Botto, F.Szeifert and L.Nagy, Identification and control of non-linear systems using fuzzy Hammerstein models, *Industrial Chemical Engineering Research*, (39), pp 4302-4314, 2000.
- [105] F.Gao, F.Wang and M.Li, A neural network based non-linear controller using an extended Kalman filter, *Industrial Chemical Engineering Research* 38, pp 2345-2349, 1999.
- [106] A.F.MacAlister, P.J.Reeve and P.Smith, Predictive control of temperature and width for heat strip Mills, *Proceedings of IFAC Automation in Mining, Mineral and Metal Processing*, pp 233-239, 1998.
- [107] H.Frank, R.Pichler, M.Schoisswohl and W.Staufner, Improved rolling-Mill Automation by means of advanced control techniques and process models, *Proceedings of IFAC Automation in Mining, Mineral and Metal Processing*, pp 305-313, 1998.
- [108] D.Sbarbaro-Hofer, D.Neumerkel and K.Hunt, Neural control of a steel rolling mill, *IEEE Control Systems* (6), pp 69-75, 1993.
- [109] H.K.D.H.Bhadeshia, Neural networks in materials science, *ISIJ International*, 39, (10), pp 966-979, 1999.
- [110] S.Datta, J.Sil and M.K.Banerjee, Petri neural network model for the effect of controlled

- thermomechanical process parameters on the mechanical properties of HSLA steels, *ISIJ International*, 39, (10), pp 986-979, 1999.
- [111] Y.Otsuka, M. Konishi, K.Hanaoka and T.Mak, Forecasting heat levels in blast furnaces using a neural network model, *ISIJ International*, 39, (10), pp 1047-1052, 1999.
- [112] W.Chen, G.Duan and C.Ou, Neural network applied to predicting molten steel temperature profile from converter to continuous casting, *Iron and Steel (CHINA)*, 32, (8), pp 30-32, 1997.
- [113] H.T.Ngyena and M.Sugeno, *Fuzzy systems: Modelling and control*, Kluwer Academic Publishers, ISBN 0-7923-8112-2, 1998.
- [114] S.K.Das, Numerical formalism for solving heat transfer in continuous casting process by nonorthogonal co-ordinate transformation strategy, *Scandinavian Journal of Metallurgy*, (22), pp198-202, 1993.
- [115] F.R.Camisani-Calzolari, I.K.Graig and P.C.Pistorius, On the control of the secondary cooling zone in continuous casting, *Proceedings of IFAC Automation in Mining, Mineral and Metal Processing*, pp 31-36, 1998.
- [116] S.Guan, X.Wang, T.Chai and X.Wang, The slab accelerating cooling system control model and its application study, *Proceedings of IFAC Automation in Steel Industry: Current Practice and Future Developments*, pp 219-224, 1997.
- [117] M.El-Bealy, N.Leskinen and H.Fredriksson, Simulation of cooling conditions in secondary cooling zones in continuous casting process, *Ironmaking and Steelmaking* 22, (3), pp 246-255, 1995:
- [118] K.Sigeru et al., On the secondary cooling control technology for the continuous casting-direct rolling processes, *Nippon Steel Technical Report* (23), pp 69-79, 1984.
- [119] P.Löber, *Industrielle Steuerungstechnik*, Institut für Automatisierungstechnik, TU Bergakademie Freiberg 01.01.2000.
- [120] J.Laine, Analysis and monitoring of continuous casting mould with the self-organisation map, *European Commission for Technical Steel Research, ECSC Workshop, Proceedings of Application of Artificial Neural Network Systems in the Steel Industry*, Brussels 22-23 January, pp 151-155, 1998.
- [121] U.Dilthey and J.Heidrich, Using AI-methods for parameter scheduling, quality control and weld geometry determination in GMA-welding, *ISIJ International*, 39, (10), pp 1067-1074, 1999.
- [122] H.Nazaki, T.Iwatani, K.Omura, Y.Otsuka and M.Konishi, An AI tool and its applications to diagnosis problems, *ISIJ International*, 30, (2), pp 98-104, 1990.