

Europäische Radonschutzkonferenz

Radon protection conference

Neue Herausforderungen für die Bau- und Lüftungsbranche

New challenges for the European construction and ventilation branches

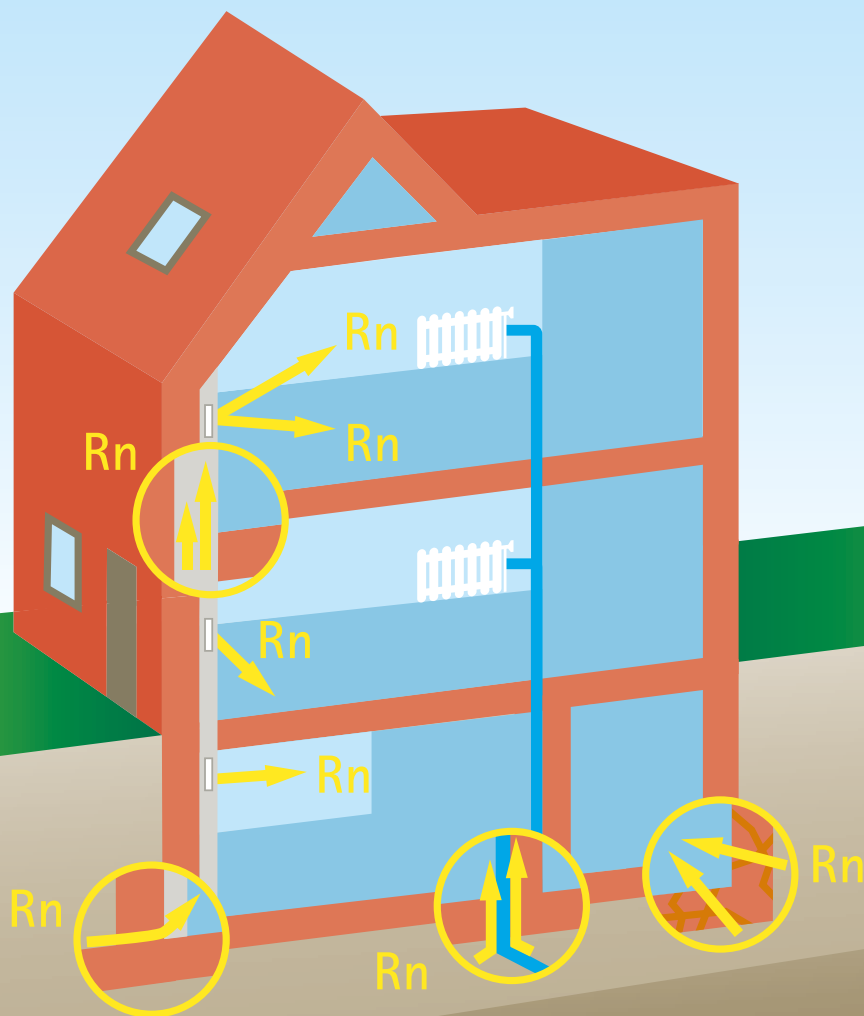

Inhalt / content

Programm / agenda	04	
Willkommen / welcome	06	
Teilnehmerliste / participant list	08	
Referentenliste / list of speakers	12	
Fachvorträge / articles		
Jiranek, Martin		
Radon protective and remedial measures in the Czech Republic	14	
Scivyer, Chris		
The evolution of practical and cost-effective radon solutions for new and existing UK buildings	18	
Dorusch, Falk; Fregnan, Franco		
A Recommendation for Radon Restorations/ Guidance for Optimal Restoration Process	22	
Collignan, Bernard		
French experience in management and research on the protection of building with respect to radon	26	
Knez, Friderik		
Radon mitigation in Slovenia	28	
Holmgren, Olli; Arvela, Hannu		
Finnish experiences in radon prevention in new construction and energy saving constructions	32	
Karimi-Auer, Julia		
Baupraxis betreffend Radon in Österreich – Regelungen, Erfahrungen und Zukunftsausblick	36	
Bochicchio, Francesco		
The approach of the Italian National Action Plan on radon for prevention in new buildings and mitigation in existing buildings and considerations on the effects of the forthcoming new European Directive	40	
Kerz, Nicolas		
Berücksichtigung von Radon im Bewertungssystem Nachhaltiges Bauen	44	
Uhlig, Reinhold; Hartmann, Thomas		
Regelungen des baulichen Radonschutzes für Neubau und Gebäudesanierung in Deutschland – aktueller Stand und erforderliche Entwicklungen unter Berücksichtigung der neuen Europäischen Richtlinie	46	
Linares-Alemparte, Pilar		
The future Spanish Building Code on the radon protection area and the current regulatory situation in Spain	50	
Smyth, Eamonn		
Radon in Ireland and the New National Radon Strategy	54	
Park, Mattias		
Radon mitigation in dwellings using radon extractors	58	
Notizen / notes		60

Programm

Montag 02.12.2013

Grußworte

- 9:00 Uhr Hartmut Schwarze (Sächsisches Staatsministerium für Umwelt und Landwirtschaft)
9:10 Uhr Alf Furkert (Architektenkammer Sachsen)
9:20 Uhr Klaus Pöllath (Hauptverband der Deutschen Bauindustrie e.V.)

Fachvorträge

- 9:30 Uhr Martin Jiranek (TU Prag, Tschechien): Radonschutz- und -sanierungsmaßnahmen in Tschechien
10:15 Uhr Chris Scivyer (BRE, UK): Die Entwicklung von praktischen und kosteneffektiven Lösungen für neue und bestehende Gebäude im Vereinigten Königreich
11:00 Uhr Falk Dorusch (FHNW, Schweiz): Eine Empfehlung zum Vorgehen bei Radonsanierungen /
Wegleitung für den optimalen Sanierungsablauf
11:45 Uhr Mittagspause
13:00 Uhr Bernard Collignan (CSTB, Frankreich): Französische Erfahrungen in Bezug auf Anwendung und
Forschung im Bereich des Radonschutzes in Gebäuden
13:45 Uhr Friderik Knez (ZAG, Slowenien): Radonsanierung in Slowenien
14:30 Uhr Olli Holmgren (STUK, Finnland): Finnische Erfahrungen im Radonschutz bei neuen Gebäuden und
beim energetischen Bauen
15:15 Uhr Kaffeepause
15:45 Uhr Julia Karimi-Auer (STMK, Österreich): Baupraxis betreffend Radon in Österreich – Regelungen,
Erfahrungen und Zukunftsausblick
16:30 Uhr Francesco Bochicchio (ISS, Italien): Die Herangehensweise des italienischen Aktionsplans zum
Radonschutz in neuen Gebäuden und bei der Sanierung bestehender Gebäude und Überlegungen
über die Auswirkungen der neuen EU Grundnorm
17:00 Uhr Nicolas Kerz (BBSR, Deutschland): Berücksichtigung von Radon im Bewertungssystem
Nachhaltiges Bauen
19:00 Uhr gemeinsames Abendessen im Augustiner an der Frauenkirche

Dienstag 03.12.2013

Fachvorträge

- 9:00 Uhr Thomas Hartmann (ITW Dresden): Regelungen des baulichen Radonschutzes für Neubau und Ge-
bäudesanierung in Deutschland – aktueller Stand und erforderliche Entwicklungen unter Berück-
sichtigung der neuen Europäischen Richtlinie
9:45 Uhr Pilar Linares (CSIC, Spanien): Die zukunftsfähige spanische Baurichtlinie zum Radonschutz und die
gegenwärtige Rechtssituation in Spanien
10:30 Uhr Kaffeepause
11:00 Uhr Eamonn Smyth (DECLG, Irland): Radon in Irland und die neue nationale Radonstrategie
11:45 Uhr Mattias Park (Corroventa, Schweden): Radonminimierung in Gebäuden mit Lüftungsanlagen
12:30 Uhr Mittagspause
13:30 Uhr Malgorzata Wysocka / Krzysztof Ciupek (Polen): Radonmessungen in Polen

Podiumsdiskussion

- 14:15 Uhr Offene Fragen vor Umsetzung der EU-Grundnorm
Diskussionsleitung: Oliver Solcher (Fachverband Luftdichtheit im Bauwesen e. V.)
15:45 Uhr Ende der Veranstaltung

agenda

Monday, 2nd December 2013

Opening session

- 9.00 h Hartmut Schwarze (Ministry for the Environment and Agriculture)
9.10 h Alf Furkert (Chamber of Saxon Architects)
9.20 h Klaus Pöllath (German Construction Industry Federation)

Presentations

- 9.30 h Martin Jiranek (Czech Technical University Prague): Radon protective and remedial measures
in the Czech Republic
10.15 h Chris Scivyer (BRE, UK): The evolution of practical and costeffective radon solutions for new and
existing buildings in the UK
11.00 h Falk Dorusch (FHNW, Switzerland): A Recommendation for Radon Restorations /
Guidance for Optimal Restoration Process
11.45 h Lunch break
13.00 h Bernard Collignan (CSTB, France): French experience in management and research on the protection
of buildings with respect to the radon
13.45 h Friderik Knez (ZAG, Slovenia): Radon mitigation in Slovenia
14.30 h Olli Holmgren (STUK, Finland): Finnish experiences in radon prevention in new construction and
energy saving constructions
15.15 h Coffee break
15.45 h Julia Karimi-Auer (STMK, Austria): Building practices concerning radon in Austria – regulations,
experiences and future prospects
16.30 h Francesco Bochicchio (ISS, Italy): The approach of the Italian National Action Plan on radon for pre-
vention in new buildings and mitigation in existing buildings and consideration on the effects of the
forthcoming new European Directive
17.00 h Nicolas Kerz, (BBSR, Germany): Addressing of Radon at the Assessment System Sustainable Building
19.00 h Dinner in the Restaurant Augustiner next to Womans Church

Tuesday 3rd December 2013

Presentations

- 9.00 h Thomas Hartmann (ITW Dresden): Regulations of edificial radon protection for new and existing
buildings in Germany – current state and required developments considering the upcoming BSS
9.45 h Pilar Linares (CSIC, Spain): The future Spanish Building Code on the radon protection area and the
current regulatory situation in Spain
10.30 h Coffee break
11.00 h Eamonn Smyth (DECLG, Ireland): Radon in Ireland and the new national radon strategie
11.45 h Mattias Park (Corroventa, Sweden): Radon mitigation in dwellings using radon exctractors
12.30 h Lunch break
13.30 h Malgorzata Wysocka / Krzysztof Ciupek (Poland): Radon measurements conducted in Poland

Panel discussion

- 14.15 h Open questions regarding the implimantation of the European directive
Chair: Oliver Solcher (Association for Air-Tightness in Buildings)
15.45 h End of workshop

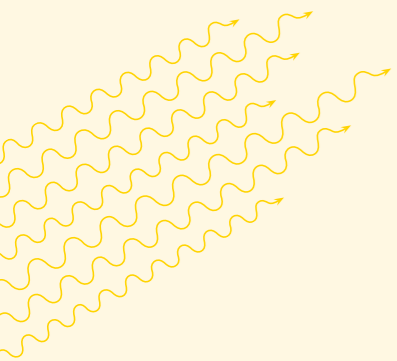

Willkommen

Zur europäischen Radonschutzkonferenz am 02. und 03. Dezember 2013 heißen wir Sie herzlich in Dresden willkommen.

Das Schwerpunktthema dieser Veranstaltung ist der bauliche Radonschutz vor dem Hintergrund der anstehenden EU-Richtlinie - RICHTLINIE DES RATES zur Festlegung grundlegender Sicherheitsnormen für den Schutz vor den Gefahren einer Exposition gegenüber ionisierender Strahlung und zur Aufhebung der Richtlinien 89/618/Euratom, 90/641/Euratom, 96/29/Euratom, 97/43/Euratom und 2003/122/Euratom.

Diese Richtlinie steht kurz vor der Verabschiedung. Die Mitgliedstaaten der EU sind verpflichtet, sie bis zum Jahr 2018 in nationales Recht umzusetzen. Sie enthält erstmals verbindliche Regelungen zur Einhaltung eines Referenzwertes für Radon in Gebäuden. Es handelt sich um den für Arbeitsplätze und Wohngebäude einheitlichen Wert von 300 Bq/m³.

Der Freistaat Sachsen will die Zeit bis zur Umsetzung in deutsches Recht nutzen, um sich und alle Betroffenen möglichst gut auf diese Umsetzung vorzubereiten. Dazu wurde eine Radon-Strategie beschlossen, in der die Aktivitäten zum Erreichen dieser Zielsetzung festgeschrieben wurden.

Diese bauen auf den zahlreichen bisherigen Aktivitäten des Freistaates Sachsen zum Radonschutz (www.radon.sachsen.de) auf und berücksichtigen die Forderungen zum Radonschutz an Arbeitsplätzen (Artikel 54) und zum Radonschutz in Wohnungen (Artikel 74) der o. g. Richtlinie.

Neben der Information der Öffentlichkeit und der Durchführung von Messprogrammen stellen Weiterbildungsmaßnahmen im Baubereich die wesentlichen Bestandteile dieser Strategie dar.

In der Praxis kann Radonschutz entweder durch eine ausreichende Dichtheit der erdberührenden Bauteile eines Gebäudes, durch das Absaugen und Ausleiten der Bodenluft unterhalb eines Gebäudes oder durch eine ausreichende Belüftung im Gebäude erreicht werden. Diese im Grunde einfachen Sachverhalte gilt es an die Hauseigentümer, aber auch an die Träger öffentlicher Gebäude sowie an alle betroffenen Institutionen des Baubereiches zu vermitteln. Des Weiteren müssen die Betroffenen über die technischen Maßnahmen zum Erreichen der Gebäudedichtheit und / oder der geeigneten Methode zur Bodenluftableitung oder zum Erreichen der Luftwechselrate informiert werden.

In den meisten europäischen Ländern gibt es schon seit vielen Jahren Aktivitäten zum Radonschutz. Einige Länder haben gesetzliche Regelungen entwickelt, welche über die der anstehenden Richtlinie hinausgehen.

Der Freistaat Sachsen will die Kenntnisse und die Erfahrungen, die bei den europäischen Nachbarn vorhanden sind, nutzen. Er pflegt aus diesem Grund mit einigen europäischen Kollegen bereits seit vielen Jahren einen fachlichen Austausch.

Wir freuen uns, dass für die Konferenz 14 Referenten aus 13 europäischen Ländern gewonnen werden konnten, die ihre Erfahrungen und Erwartungen in Bezug auf die anstehenden Regelungen vorstellen.

Auch freuen wir uns, dass viele Teilnehmer aus den unterschiedlichsten Berufsfeldern und Institutionen sich für dieses Thema interessieren und bedanken uns für ihre Teilnahme und ihren individuellen Beitrag zu dieser Konferenz.

welcome

We welcome you to the European Radon Conference in Dresden, December 2nd and 3rd 2013!

The focus of this convention is constructional and physical radon protection against the background of the upcoming European Union (EU) basic safety standards – Council Directive laying down basic safety standards for protection against the dangers arising from exposure to ionising radiation; replacing 89/618/Euratom, 90/641/Euratom, 96/29/Euratom, 97/43/Euratom and 2003/122/Euratom.

This directive is on the brink of enacting. EU Member States are obliged to implement it in national law until 2018. For the first time binding regulations to comply with a reference level for indoor Radon are part of this directive. At workplaces and in dwellings the standardized value of 300 Bq/m³ is stipulated.

The German Federal State of Saxony is intending to use the time until the implementation into German law to prepare the regulatory body and all concerned parties as good as possible for 2018. Therefore a Radon-Strategy was developed and concluded where the activities to accomplish this aim were defined.

These activities are based on numerous previous programs and actions for radon protection of the State of Saxony. They take the requirements of the new Council Directive into consideration, especially regarding radon protection on workplaces (article 53(54)) and radon protection in dwellings (article 74).

Beside the information of the public and the realization of measurement programs, training measures in the building construction sector are the main components of this strategy.

In practice radon protection can be realized either by sufficient airtightness of the building parts with direct contact to the foundation, or by extraction and discharge of the soil air below a building, or by adequate ventilation of the building. These essentially simple facts must be communicated to house owners but also to responsible persons for public buildings and to all concerned institutions in the building construction area. Additionally they have to be informed about the technical means to attain airtightness of buildings and/or adequate methods to extract soil air or to achieve the required rate of air change.

In most of the European countries since many years activities for radon protection exist. Some countries developed legal regulations with standards exceeding (i.e. below) those of the new Council Directive.

The Federal State of Saxony is happy to have advantage of know-how and experiences of the European neighbors and is willing to share own knowledge and experience with them. Therefore since many years fruitful exchange with some of the European colleagues was practiced.

We are happy to welcome 14 speakers from 13 European countries to our conference who will present their experiences and expectations regarding the upcoming regulation.

And we are very happy too about the great number of participants from different professional fields and institutions who are interested in this topic.

We want to thank you all for your participation and your individual contributions to this conference.

Teilnehmerliste / participant list

Üllar Alev

Tallinn University of Technology
Estonia

Roland Baumann

Institut f. Strahlenschutz
Germany

Gianluca Bertoni

Econs SA
Switzerland

Tobias Beyermann

Gebäudemess technik
Germany

Steffen Bieder

BFW Mitteldeutschland e.V.
Germany

Patrycja Bielawska-Roepke

Ingenieurkammer Sachsen
Germany

Gerhard Binker

Binker Materialschutz GmbH
Germany

Luca Bonzi

Tecnavia S.A.
Switzerland

Patrick Bruggmann

Ampack AG
Germany

Krzysztof Ciupek

Central Laboratory for Radiological Protection
Poland

Roberto Colucci

Tecnavia S.A.
Switzerland

Elzbieta Domin

Wroclaw University of Technology
Poland

Katrin Dörfelt

Verein RADIZ Schlema e. V.
Germany

Anita Duschek

Landkreis Zwickau
Germany

Antje Eichler

Hauptverband der Deutschen Bauindustrie e. V.
Germany

Freia Frankenstein-Krug

Sächsische Energieagentur SAENA GmbH
Germany

Bettina Gabriel

Staatsbetrieb Sächsisches Immobilien- und
Baumanagement (SIB)
Germany

Kunibert Gerij

BFW Berlin
Germany

Julia Gilberg

Technische Universität Dresden
Germany

Volker Grimm

Technische Hochschule Mittelhessen
Germany

Gerlinde Frieda Grimm

Technische Hochschule Mittelhessen
Germany

Uwe Heidrich

Hochschule Zittau/Görlitz
Germany

Ivo Heiland

Staatsbetrieb Sächsisches Immobilien-
und Baumanagement
Germany

Thomas Heinrich

Staatliche Betriebsgesellschaft für Umwelt und
Landwirtschaft (BfUL)
Germany

Hartmut Herzberg

Herzberggebäudeanalyse GmbH
Germany

Michael Hesse

SealEco GmbH
Germany

Sue Hodgson

Public Health England - Centre for Radiation Chemical
and Environmental Hazards
England

Grit Höfer

Bauindustrieverband Sachsen/Sachsen-Anhalt
Germany

Gunnar Horak

SARAD Geolab GmbH
Germany

Christian Huber

Atelier für Architektur
Germany

Stephanie Hurst

Sächsisches Staatsministerium für Umwelt und
Landwirtschaft (SMUL)
Germany

Oliver Jann

Bundesanstalt für Materialforschung und -prüfung
Germany

Thomas Junge

DREWAG-Stadtwerke Dresden
Germany

Andrea Kaltz

Sächsisches Landesamt für Umwelt, Landwirtschaft
und Geologie (LfULG)
Germany

Joachim Kemski

Sachverständigenbüro
Germany

Klaus Konschak

GAMMA-CONSULT STREHLA
Germany

Heinz-Günter Kraus

Verein RADIZ Schlema e. V.
Germany

Jörg Kropp

Hochschule Bremen
Germany

Agata Kula

Wroclaw University of Technology
Poland

Frank Leder

Sächsisches Staatsministerium für Umwelt und
Landwirtschaft (SMUL)
Germany

Bernd Leibring

GEOPRAX - Bergtechnisches Ingenieurbüro
Germany

Dana Marceta

Landesamt für Umwelt, Wasserwirtschaft und
Gewerbeaufsicht Rheinland-Pfalz
Germany



Hans-Christoph Mehner
Hochschule Zittau-Görlitz
Germany

Winfried Meyer
Bundesamt für Strahlenschutz
Germany

Wolfgang Misch
Deutsches Institut für Bautechnik (DIBt)
Germany

Jens Müller
Gemeindeverwaltung Bad Schlema
Germany

Dimitar Natchev
Ingenieurkammer Bulgarien
Bulgaria

Oscar Nordlund-Ristori
Independia Group
Sweden

Jerzy Olszewski
Institute of Occupational Medicine
Poland

Sandra Patalla
RheinEnergie AG
Germany

Ralf Pörschke
Architekt
Germany

Werner Preuße
Staatliche Betriebsgesellschaft für Umwelt und
Landwirtschaft (BfUL)
Germany

Roland Preusser
AQUATERRA Dresden GmbH
Germany

Tadeusz Przylibski
Wroclaw University of Technology
Poland

Axel Puhlmann
BFW Bau Sachsen e.V.
Germany

Kathrin Reichelt-Georgi
Sächsisches Staatsministerium des Innern
Germany

Wolfgang Ringer
Österreichische Agentur für Gesundheit und
Ernährungssicherheit (AGES)
Austria

Josef Rittgen
Rittgen - Beratende Ingenieure
Germany

Franz Anton Röbler
Technische Hochschule Mittelhessen
Germany

Andrea Sperrhacker
Sächsisches Landesamt für Umwelt, Landwirtschaft
und Geologie (LfULG)
Germany

Maria Stefano
Ingenieurkammer Bulgarien
Bulgaria

Karsten Steudel
Landratsamt Zwickau
Germany

Kurt Sudeck
Germany

Corina Thiele
Sächsisches Staatsministerium der Finanzen
Germany

Markus Trautmannsheimer
Bayerisches Staatsministerium für Umwelt und Verbraucherschutz
Germany

Cornelia Trültzsch
Sächsisches Staatsministerium für Wirtschaft, Arbeit und Verkehr
Germany

Verena Tykiel
Deutsches Institut für Bautechnik (DIBt)
Germany

Frank Ullrich
Thüringer Landesanstalt für Umwelt und Geologie (TLUG)
Germany

Corina Unger
SARAD GmbH
Germany

Giancarlo Vanoni
Tecnavia S.A.
Italy

Katarzyna Walczak
Institute of Occupational Medicine
Poland

Sabine Wehrenpennig
Landeshauptstadt Dresden, Stadtplanungsamt
Germany

Johan Wintheim
Independia Group
Germany

Friedrich Wodarczack
Hochschule Zittau-Görlitz - University of Applied Sciences
Germany

Jana Ziemer
GICON GmbH
Germany

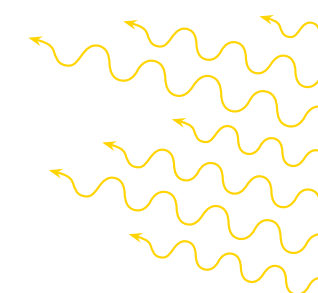

Referentenliste / list of speakers

Francesco Bochicchio

Istituto Superiore di Sanità
(Italian National Institute of Health)
Italy

Bernard Collignan

Centre Scientifique et Technique du Bâtiment
(Scientific and Technical Center for Building)
France

Falk Dorusch

FHNW, University of Applied Sciences Northwestern
Switzerland
Switzerland

Alf Furkert

Architektenkammer Sachsen
(Chamber of Saxon Architects)
Germany

Thomas Hartmann

Institut für Technische Gebäudeausrüstung Dresden (ITG)
(Institute for Building Systems Engineering Dresden)
Germany

Olli Holmgren

Radiation and Nuclear Safety Authority - STUK
Finland

Martin Jiranek

Czech Technical University Prague
Czech Republic

Julia Karimi-Auer

Amt der Steiermärkischen Landesregierung
(Agency of the Styrian Government)
Austria

Nicolas Kerz

Bundesinstitut für Bau-, Stadt- und Raumforschung (BBSR)
(Federal Institute for Research on Building, Urban Affairs and
Spatial Development)
Germany

Friderik Knez

ZAG - Slovenian National Building and Civil
Engineering Institute
Slovenia

Pilar Linares-Alemparte

Eduardo Torroja Institute of Construction Sciences
(CSIC)
Spain

Mattias Park

Corroventa Avfuktning AB
(Corroventa dehumidification)
Sweden

Klaus Pöllath

Hauptverband der Deutschen Bauindustrie e. V.
(German Construction Industry Federation)
Germany

Hartmut Schwarze

Sächsisches Staatsministerium für Umwelt und
Landwirtschaft (SMUL)
(Saxon State Ministry of the Environment
and Agriculture)
Germany

Christopher Scivyer

Building Technology Group, (BRE)
England

Eamonn Smyth

Dep. of the Environment, Community and Local
Government (DLCLG)
Ireland

Oliver Solcher

Fachverband Luftdichtigkeit im Bauwesen e. V.
(Association for Air-Tightness in Building)
Germany

articles

Radon protective and remedial measures in the Czech Republic

Martin Jiránek

Czech Technical University in Prague, Faculty of Civil Engineering, Czech Republic, email: jiranek@fsv.cvut.cz

Abstract

Principles of designing and realization of radon preventive and remedial measures in the Czech Republic are described. Requirements for radon-proof membranes and other components that are part of radon reduction systems are presented.

1. Protection of new buildings

Principles of protection

Design and realization of radon preventive measures has been standardised in the Czech Republic since 1995, when the Czech national standard CSN 730601 „Protection of buildings against radon from the soil” [1] was introduced. The way in which protection is carried out depends on the radon index of the building. This quantity is determined by the radon index of the foundation soils, type of building and its position in the soil profile with respect to the ground level and by all building activities influencing the permeability of foundation soils. Principles of protecting buildings with respect to radon index of the building are summarized in Tab. 1.

Radon index of the building	Protection
Low	Continuous waterproof membrane
Medium	Continuous radon-proof membrane
High	Continuous radon-proof membrane in combination with either sub-slab ventilation, or air-gap ventilation

If the permeable gravel layer is placed under the house or the ground floor is equipped with an underfloor heating, radon-proof membrane must be provided in combination with either sub-slab ventilation, or air-gap ventilation regardless of the radon index of the building.

Tab. 1. Principles of protecting new buildings

Radon-proof membrane

The only materials that may be used as radon-proof membranes are those with barrier properties that have been verified by measuring the radon diffusion coefficient [2, 4, 5], and that have proven durability corresponding to the expected lifetime of the building. Bitumen membranes with Al foil cannot serve as a radon-proof membrane due to their very low tear resistance, and plastic membranes with dimples are unsuitable due to evidence that it is almost impossible to form airtight joints with this material. Applicability of the particular membrane for a specific dwelling is derived from the calculation of its thickness. The calculation takes into account the radon diffusion coefficient in the insulation, soil parameters (radon concentration and permeability) and house characteristics (area in contact with the soil, air exchange rate and interior air volume) [1, 3].

Sub-slab ventilation

Sub-slab ventilation systems in new buildings are usually provided by a network of flexible perforated pipes placed in a sub-floor layer of coarse gravel. Perforated pipes are connected to a vertical exhaust pipe, which terminates above the roof. A typical arrangement of a sub-slab ventilation system is shown in Fig. 1, and a floor structure with soil ventilation is presented in Fig. 2. The soil air is sucked from the perforated pipes by a fan or rotating cowl that is installed at the top of the vertical exhaust pipe.

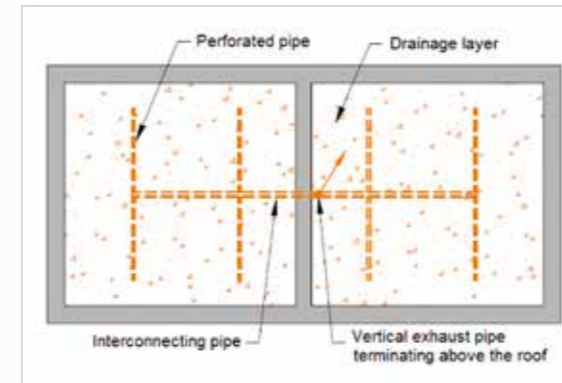

Fig. 1. Network of perforated pipes convenient for new buildings

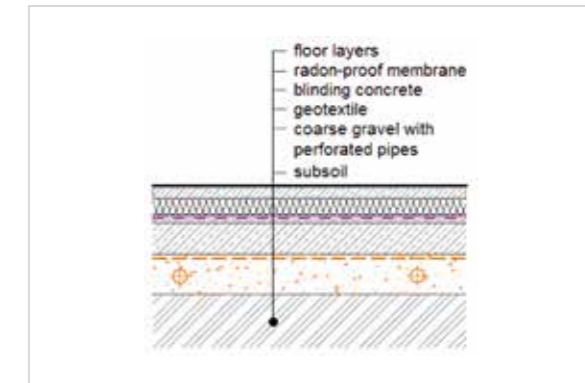

Fig. 2. Floor structure with the soil ventilation

Floor air gap ventilation

Air gaps in floor structures are usually formed by plastic membranes with dimples or various types of plastic profiled components. The floor air gap can be created above or under a radon-proof membrane (Fig. 3). The best solution is to ventilate the air gap above the roof. Natural or forced ventilation can be used. A slight underpressure within the gap is recommended

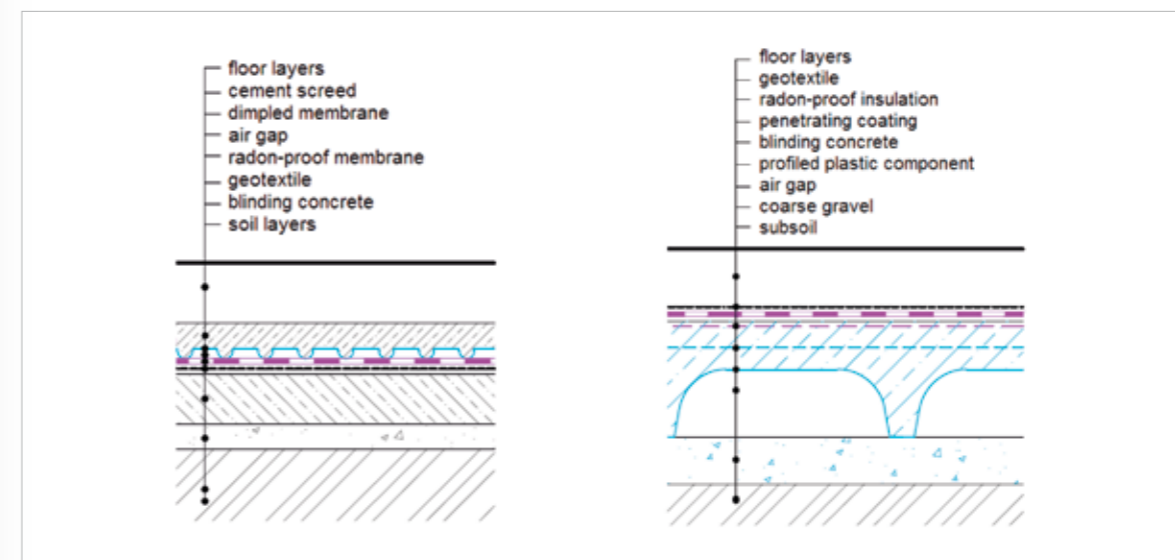

Fig. 3. Floor structure with an air gap above or below a radon-proof membrane

2. Remediation of existing buildings

Principles of remediation

The type and the level of remediation depends on the degree of exceeding the reference level 400 Bq/m^3 for indoor radon concentration, type of the house and applicability of the measure into the existing structure.

Buildings in which the reference level is not so much exceeded (indoor radon concentration is below 600 Bq/m^3) can be easily and inexpensively mitigated by sealing of radon entry routes, improving the cellar – outdoor ventilation, preventing the air movement from the cellar into the first floor, increasing the ventilation intensity, etc.

Buildings with indoor radon concentration above 600 Bq/m^3 should be remediated by more effective methods. The basic and the most effective solution is the installation of a sub-slab depressurization. The preference should be given to systems that can be installed without the reconstruction of floors and obstructions within the living space. The soil air can be sucked from perforated tubes drilled into the sub-floor layer from the cellar (Fig. 4) or from an external trench excavated in the ground along one or more sides of the house (Fig. 5). Other possibility is to install the perforated tubes from the floor pit excavated in one room, where afterwards a new floor with a radon-proof membrane had to be placed (Fig. 6). Beneath each habitable room at least one perforated pipe should be inserted.

Fig. 4. Perforated tubes drilled into the sub-floor layer from the cellar

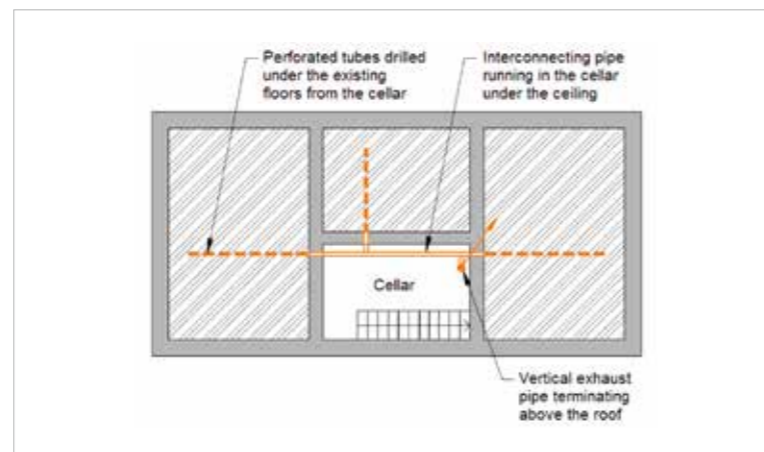

Fig. 5. Perforated tubes drilled into the sub-floor layer from the external trench

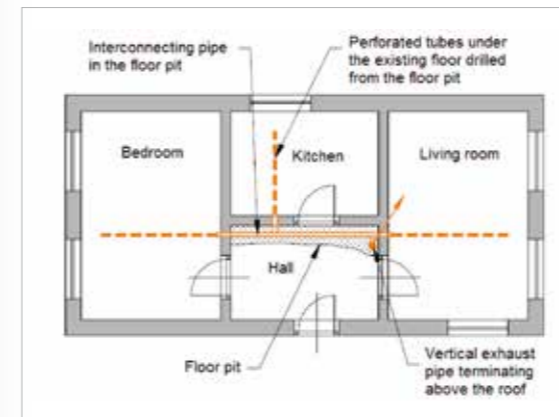
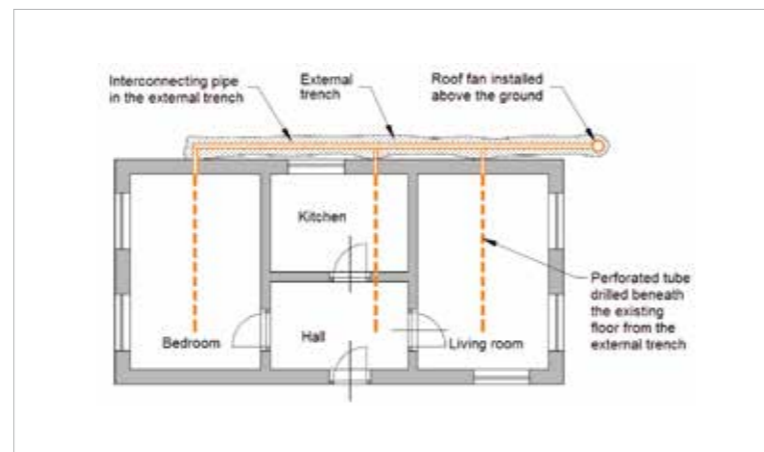

Fig. 6. Perforated tubes installed from the floor pit excavated in one room

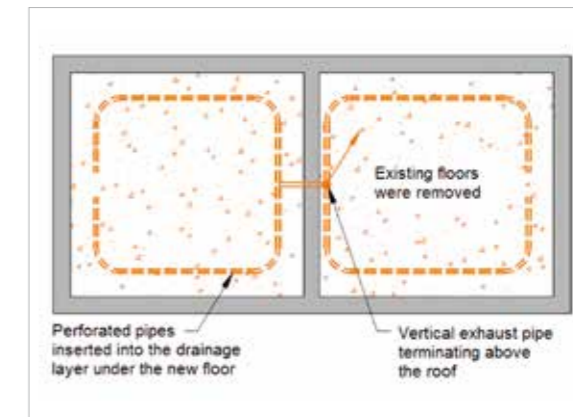

Fig. 7. Network of perforated pipes in the drainage layer suitable for remediation

In houses with damp walls and floors the possible best solution could be the installation of ventilated floor air gaps or replacement of existing floors by new ones in which the radon-proof insulation and the soil depressurization system will be combined. Flexible perforated pipes placed in a sub-floor layer of coarse gravel (Fig. 7) are usually used for soil air suction. Pipes are laid along walls in order to stop radon from entering the dwelling through the wall-floor joint or through vertical holes and cracks within the wall.

Passive ventilation of soil or air gaps is usually not sufficient and therefore forced ventilation is recommended. The fan is usually installed at the top of a vertical exhaust

pipe or in a suitable place in the garden. Passive systems must be installed in such a way that they can be very easily changed to forced systems.

In existing houses radon-proof insulation, as a single measure is not so effective, because it usually cannot be applied under the walls and thus radon can be still transported through wall-floor joints. Therefore combination with a soil ventilation system is recommended.

3. Acknowledgement

This paper has been supported by the research project P104/11/1101, funded by the Grant Agency of the Czech Republic.

References

1. SN 73 0601 Protection of houses against radon from the soil. Czech Standards Institute, Praha 2006
2. Jiránek M, Fronka A.: New technique for the determination of radon diffusion coefficient in radon-proof membranes. Radiation Protection Dosimetry 2008; 130(1): 22-25.
3. Jiránek M, Hulka J.: Applicability of Various Insulating Materials for Radon Barriers. In: The Science of the Total Environment 272 (2001), pp 79-84
4. Jiránek M, Svoboda Z.: Transient radon diffusion through radon-proof membranes: A new technique for more precise determination of the radon diffusion coefficient, Building and Environment (2008), doi:10.1016/j.buildenv.2008.09.017
5. Jiránek M., Kotrbatá M.: Radon diffusion coefficients in 360 waterproof materials of different chemical composition. In: Radiation Protection Dosimetry (2011), doi:10.1093/rpd/ncr043

‘The evolution of practical and cost-effective radon solutions for new and existing UK buildings’

Chris Scivyer MCIQB

Principal Consultant, Building Research Establishment Limited,
Garston, Watford WD25 9XX, UK

Introduction

The UK radon programme has been running for nearly 30 years, in which time a considerable amount of progress has been made in understanding the physics of radon, developing a comprehensive range of cost effective radon solutions for both new and existing buildings, and engaging with officials and professionals in health, construction, and property transactions, as well as the general public.

Problems with radon in water and radon emanating from building materials are both rare in the UK. We are primarily concerned with reducing the amount of radon that enters buildings from the ground.

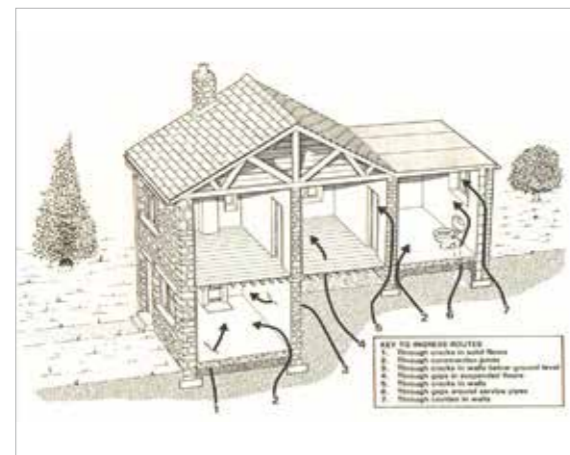

Figure 1: the various routes by which radon gas enters a building from the ground.

Reducing radon levels in existing buildings

Many different remedial methods have been trialled in the UK over the years with varying degrees of success. As a result of this work we now have a set of three key techniques that can be used to solve the majority of radon problems in existing homes and other buildings:

- Improved house ventilation
- Improved underfloor ventilation (natural or mechanical ventilation)

- Sump systems (sub-slab depressurisation) Each can be supplemented by additional sealing works to floors, walls and service penetrations.

Average indoor radon levels exceeding 20,000 Bq/m³ have been lowered to below the UK recommended action level of 200 Bq/m³ using these techniques. Typically for homes built since the 1950's these measures are unlikely to cost more than £1200 to install and in many cases can be installed on a do-it-yourself basis by the homeowner for half



Figure 2 externally located sump system (left), whole house ventilation system (right)

the cost.

The UK government have funded a series of radon awareness campaigns since the late 1980's which have targeted areas known to have elevated radon levels. Managed on a national basis these campaigns tried to identify dwellings with elevated radon levels and encourage owners to remediate. As part of this process occupiers were offered free measurement, supplemented by guidance on remedial measures, via leaflets, telephone help lines and more recently Websites. Whilst some limited grants are also available most remedial measures have to be funded by the homeowner.

Over the last 10 years or so the government has re-focused its campaigns to fund local awareness campaigns for which the local authorities provide the public face. The key features of these campaigns are:

- Offering free measurement via the local authority
- Running training events for local authority staff, housing professionals, surveyors, builders and medical practitioners.

- Local public exhibitions and surgeries with national experts and local contractors available to advise on solutions
- Providing advice locally and in some cases home visits

These activities have proven very successful in increasing the uptake of measurement and have had resulted in increased uptake of remediation works. Their success is due to the local authorities being seen to lead the campaigns. Being managed locally the public have a local point of contact for advice and guidance. House owners trust the local authority more than the government so are more willing to act! The key aims have been to offer simple and consistent messages on health risks and remediation methods, and to minimise effort demanded of householders.

With the drive for improving energy efficiency in UK homes additional guidance is being developed to ensure that radon is considered at the same time. It is recommended that homes are tested for radon before works are undertaken and where appropriate radon solutions can be incorporated into refurbishment works.

Protecting new buildings in the UK

The various building regulations covering England and Wales, Scotland and Northern Ireland require radon protection to be provided in all new buildings in areas of significant radon risk based upon maps derived from house measurement and geological data.

For England and Wales, depending upon the risk in the area, there are three levels of protection:

- Areas where no protective measures are required
- Basic radon protection (a radon barrier across the footprint of the building).
- Full radon protection (radon barrier supplemented by a sump or subfloor void to enable subfloor depressurisation to be applied later should it prove necessary see Figure 3).

Research carried out in the early 1990's suggested a relatively high success rate with these techniques. In the case of protected suspended concrete floors with ventilated underfloor spaces 99% achieved and an average indoor

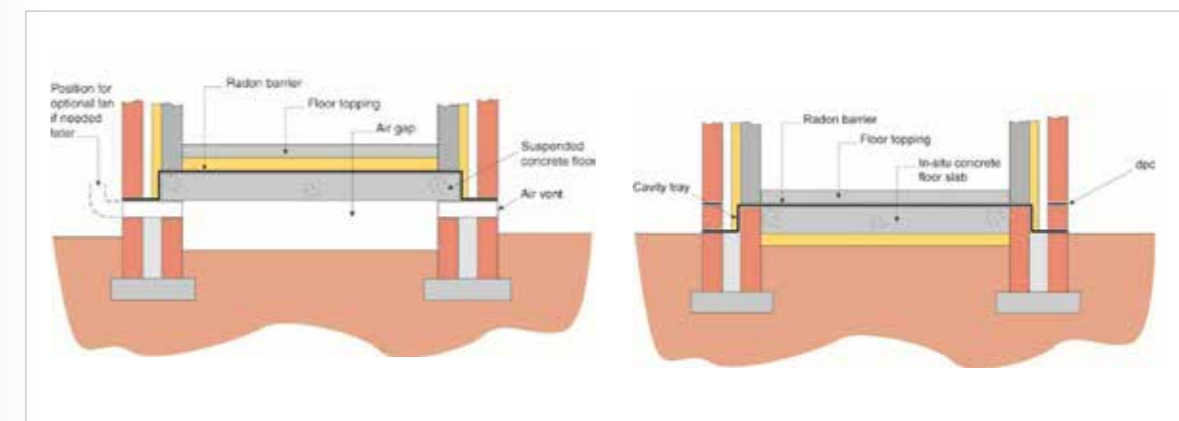

Figure 3 full radon protection to a suspended concrete floor (left) and an in-situ concrete floor (right).

radon level of less than 200 Bq/m³. In fact the average for all floor types was close to 55 Bq/m³. Interestingly properties re-tested 20 years later showed little change in the effectiveness of the protection measures. There was a slight increase nearer to 60 Bq/m³.

Whilst these results are very good recent changes to building regulations, to improve energy efficiency of buildings and to provide level access for disabled people, conflict with the detailing applied for radon protection. Furthermore we have noticed a slight increase in the number of recently built properties being identified with elevated radon levels. Further investigation is needed, but it appears that changes in design to satisfy level access are complicating the design and installation of the radon barrier and provision of underfloor ventilation. BRE are about to establish a working group of interested parties from the construction industry to review existing construction detailing and to develop revised guidance to support the Building Regulations. In addition it is intended to increase the general awareness of providing radon protection during construction. The message has unfortunately been somewhat drowned out by the drive for energy efficiency.

Training Builders

It has always been difficult to provide adequate radon training for building professionals and operatives due to the transitory nature of the construction industry and the way in which radon levels vary from area to area across the UK. One-off training events have proven successful, particularly when organised to coincide with a local radon measurement campaign and the events are subsidised. The incentive for builders to attend is the likelihood that local properties will require remediation. But interest tends to fade as the show leaves town! For areas where it is not viable to organise training events BRE have recently developed the first of a potential series of Web based training

packages. There is a small charge, but anybody wherever they are located can access it.

Radon in the Workplace

The UK has long had regulations to address the risk from radon in the workplace. Unfortunately the regulations have never really been enforced. The better employers have taken action but most have not. This is an area in which further awareness raising activities are currently being discussed.

Radon and buying and selling of property

Encouraging radon measurement and remediation as part of the buying and selling process is an important way of reducing radon risk. People are more likely to install radon reduction measures as part of other works that are being funded when moving into a property. Radon has for some time been one of the issues that is included within the standard searches that are carried out by Solicitors and Estate agents for the purchaser prior to purchase.

Conclusion

Over the last 20 years the UK has carried out a considerable amount of work to develop a range of cost-effective technical solutions for reducing radon risk in both existing and new buildings. We already satisfy the requirements of the new European Basic Safety Standard but there is further work to be done. The principal aims now are to increase the uptake of remediation measures in existing buildings and to improve the standard and consistency of protective measures installed in new buildings.

For further information visit the BRE website at www.bre.co.uk

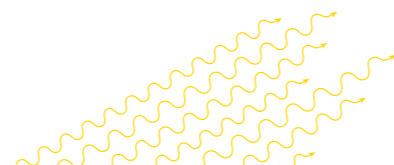
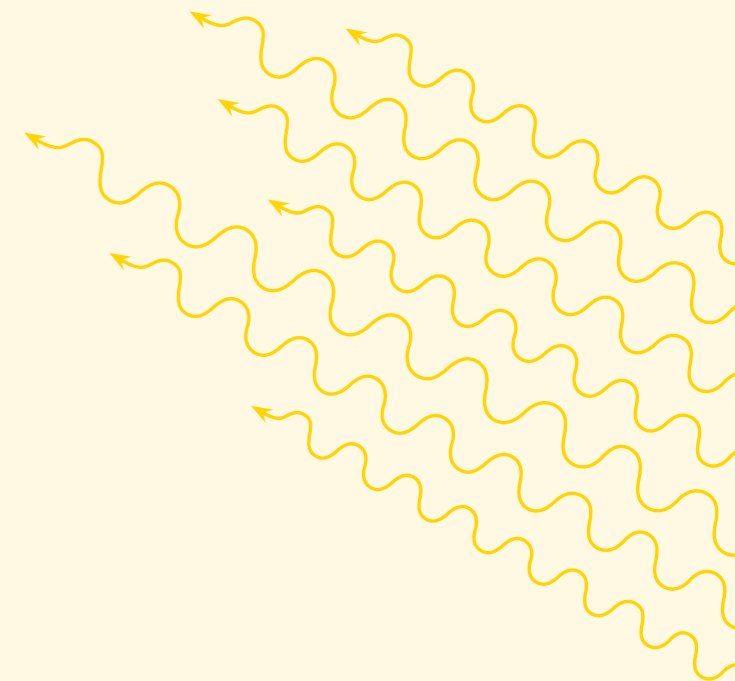

A Recommendation for Radon Restorations/ Guidance for Optimal Restoration Process

Eine Empfehlung zum Vorgehen bei Radonsanierungen/ Wegleitung für den optimalen Sanierungsablauf

Falk Dorsch, Franco Fregnan, (FHNW, Switzerland)

Institute of Energy in Building, School of Architecture, Civil Engineering and Geomatics,
University of Applied Sciences and Arts Northwestern Switzerland
www.fhnw.ch/iebau, franco.fregnan@fhnw.ch, falk.dorsch@fhnw.ch

Summary

The Swiss Federal Office of Public Health (FOPH) assigned the Institute of Energy in Building to provide a specialist department for radon in the German speaking part of Switzerland. Objectives are to support the communication and cooperation between radon experts all over Switzerland. The topic is included in trainings and education programs. Concerned house owners are supported with technical expertise in case of new building programs and restoration measures to reduce the radon concentration in buildings.

Zusammenfassung

Das Schweizerische Bundesamt für Gesundheit (BAG) hat das Institut Energie am Bau der Fachhochschule Nordwestschweiz mit der Führung einer Radonfachstelle für die Deutschschweiz beauftragt. Ziel des Mandats ist es, den fachlichen Austausch der Radonfachstellen der Westschweiz und des Tessin sowie die Kooperation unabhängiger Radonexperten zu fördern. Ebenfalls wird das Thema „Radon“ in die Aus- und Weiterbildung eingebracht. Die enge Vernetzung mit dem BAG stärkt den Austausch von Kompetenzen in der Radonprävention und -sanierung. Eine weitere Aufgabe der Radonfachstelle besteht darin, betroffene Hauseigentümer mit technischer Expertise bei Neubauprojekten und Sanierungsmassnahmen zur Reduktion des Radongehalts in Gebäuden zu unterstützen. Für den täglichen Gebrauch ist es hilfreich, das Procedere einer Radonsanierung zu strukturieren und zu vereinheitlichen. Um Radonfachpersonen, involvierten Planern und andere interessierte Fachleute die Routine einer Radonsanierung zu erleichtern, wird ein strukturiertes Vorgehen als Wegleitung, Kommunikationshilfe und Gedankenstütze vorgeschlagen.

Established Instruments/tools:

The Swiss Federal Council adopted a national action plan to protect the population from radon in habitable rooms. This plan defines appropriate and effective measures, based on newest scientific research and international standards. The topic of radon has been incorporated into updated regulations and rules [1] and is applied in 'cutting edge' building standards [2,3].

There are a lot of resources available for radon experts for planning and execution of preventive measures and remedial work [4], such as extensive building-reports on remedial work, documented examples of restorations [5], recommendations for efficient use of building technology as well as the radon-manual of Switzerland [7]. Radon experts are strongly advised to document all remedial work and use a standardized questionnaire.

Recommended Action

For daily use, it is advisable to structure and unify the approach of remedial work for radon. Radon experts, engineers and other interested parties are given an approach that can be used as guide, communication aid and mnemonic aid.

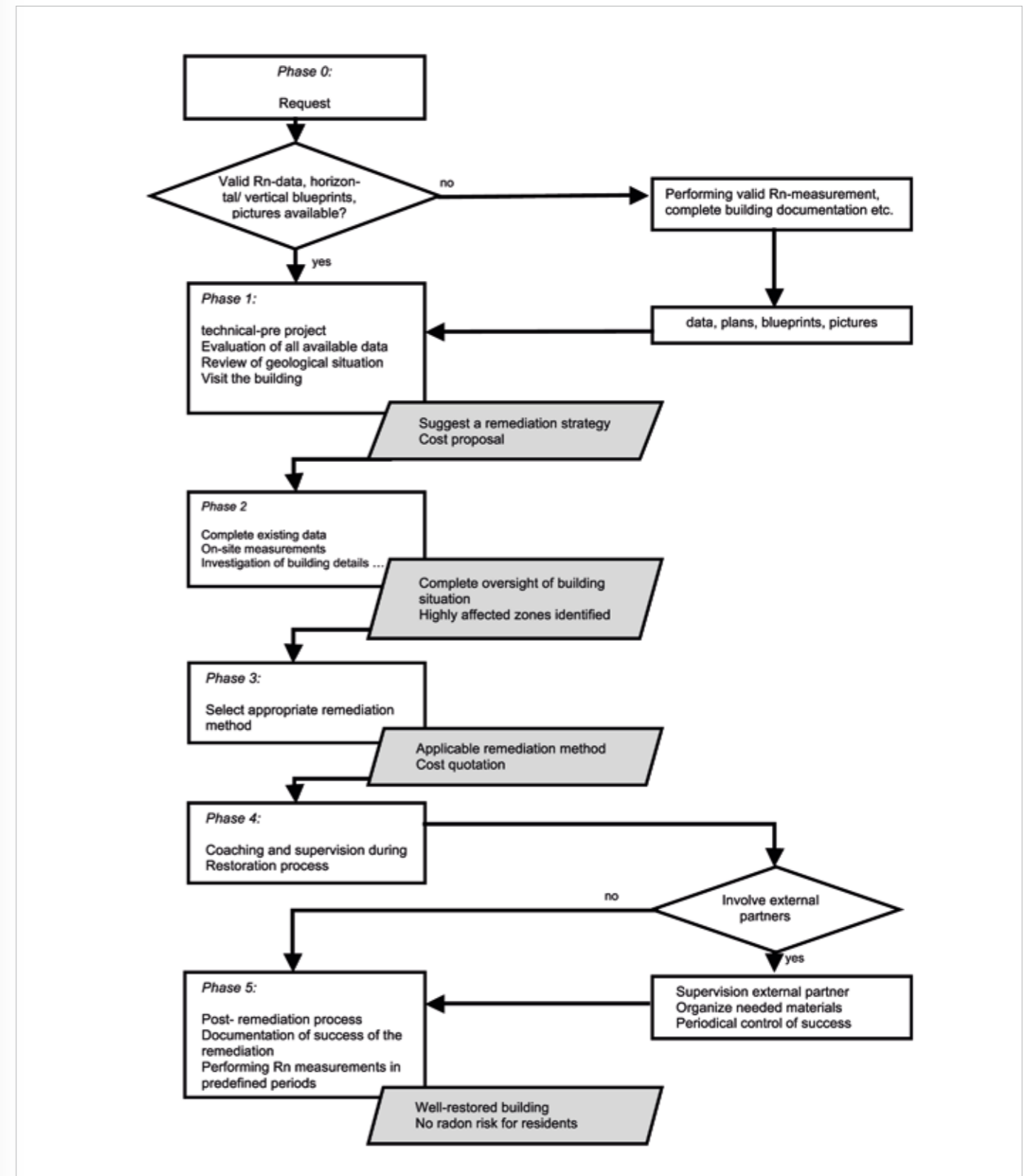

Phase 0: First Contact

Usually a radon expert is contacted by concerned building owners, engineers or architects.

In the first conversations it's important to evaluate the current situation and to find out about any suspicion the concerned person might have. The first contact should also be used to get an overview about planned, ongoing and finished work on the building in question. It can be helpful to obtain blueprints, cross-sections and pictures of the building and, if available, any existing data on the radon contamination.

The client should be asked for any available data while both parties should agree on confidentiality. Based on the available data, the radon expert can get a first overview of the situation. This first consultation is usually free of charge.

Phase 1: Technical Pre-Project, Cost Quotation

If the client shows interest for further support by the expert, a technical pre-project should be worked out.

As a preparation, all available documentation is reviewed for its correctness and completed where necessary. Building applications can be used as further resources. All building plans should be investigated for potential compromised rooms, entry points for radon as well as possible ways for it to spread in a building.

The general state of the building as well as the properties of the building should be looked upon closely. The structure of the building, the wall-, ceiling- and floor-composition and vertical or horizontal punctures in the building should be identified and evaluated.

Special care should be given to all components that are in contact with the surrounding earth. These components should be analyzed with great care, particularly with regards to potential leaking. If data exists on the radon contamination, it is to be checked for plausibility and reproducibility. It should be clear from the data when, where and in what time-interval the data have been acquired. The exact

place of the measurement should be documented and accessible in the building.

The geologic situation at the building location should be evaluated. Ideally a high-resolution geological map of the area can be used and examined for clefts, cleaves and groundwater leakages in close proximity to the building. It can be useful to consult an available ground expert testimony or to evaluate drilling expertises e.g. from geothermal probes.

For exact assessment a visit of the site and the building is insightful. The visit can be combined with a meeting with the owner or engineer. Visiting the building, it is important to compare the blueprints with the real circumstances and document the building by taking pictures. The structure and composition of the floors, walls and suspended ceilings should be investigated closely and potential entry points for radon identified and documented.

Buildings with multiple floors offer the challenge of identifying paths for radon by air convection.

Sources of radon in the building itself, such as floor covering, stone workspaces and collections of minerals should be identified. The result of the technical pre-project should be a proposal with suggestions on further assessments (measurements, analysis of building parts), a list of potential restoration measures and a time schedule. The technical pre-project is usually conducted with a fixed time-budget and the cost is included in the total project.

Phase 2: Analysis, Inventory of Deficiencies

Primarily potentially highly radon affected rooms in the building should be identified. Short measurements of potential entry points for radon - radon sniffing - during the first visit as well as checking the leakage of isolated rooms in the building with blower-door-measurements during the first visit would be ideal. If the available documents offer no insight into the composition of walls, ceilings and floors, the first visit also offers an opportunity for sensory investigation or a sounding drill hole.

The results of the visit have to be well documented. The FOPH offers a template for a site inspection protocol. The protocol should give the house owner enough information to get a clear picture of the radon risk his building is subjected to.

Possible remedial work should be outlined in the protocol which should also include recommendations from the expert.

Results of the investigation should be properly explained to the client as well as possible consequences.

The first visit can be followed up by further meetings if the owner asks for it or long-term measurements in the building, e.g. for a heating period, are required. The expert contacts the cantonal radon expert or the FOPH if necessary.

Phase 3: Selection of Remedial Work

The Selection of an appropriate remedial method is part of a multifarious decision process.

With the available data, the expert works out remedial work for the particular building.

A test might be necessary to see whether a given material or installation would provide a good solution for a particular building.

The expert researches appropriate material, contacts technical firms, manufacturers and suppliers, checks quotes and creates a definite offer of the remedial work.

Phase 4: Counsel and Supervision During the Remedial Work

During the remedial work the expert can take on many different roles. In smaller projects he can, mandated by the owner, act as general contractor and coordinate the involved parties and artisans. He suggests the contractors and organizes the different work orders. He takes care of the materials necessary and supervises the whole process. If needed, an external expert can be involved, e.g. from ma-

nufacturers, consultants from build material producers etc. If building technology such as as ventilation system is installed, the radon expert controls the startup, supervises the approval of the construction and optimizes it. After everything has been installed, another long-term measurement of radon contamination should be done.

All work and results should be documented in a report. This report should then be made available to the house owner.

Phase 5: Supervision After Remedial Work

After all remedial work has been concluded, the owner of the building should be informed of the success of the remedial work.

It is possible to issue a certificate of the radon contamination before and after remedial work as well as the remedial work that has been done.

The house owner should be informed that the success of the remedial work should be regularly checked. This «control of effect» can be made by regular measurements (e.g. every 3 to 5 years).

Sources:

- 1 Der Schweizerische Bundesrat, Strahlenschutzverordnung, 2013
- 2 Norm SIA 180, Wärmeschutz, Feuchteschutz und Raumklima in Gebäuden, in Vernehmlassung
- 3 Norm SIA 380/1, Thermische Energie im Hochbau, 2009
- 4 Bundesamt für Gesundheit, Informationen für Bauherren zu radonsichere Bauen, 2006
- 5 Bundesamt für Gesundheit, BAG-Empfehlungen: bauliche Massnahmen für Neubauten und Sanierungen, 2012
- 6 Bundesamt für Gesundheit, Radon, Einfluss der energetischen Sanierung, 2012
- 7 Bundesamt für Gesundheit, Radonhandbuch Schweiz, 2000

French experience in management and research on the protection of building with respect to radon

Bernard Collignan (CSTB, France)
DR Research Engineer

For the French population, exposure to radon is the primary source of exposure to ionizing radiation, before medical exposure. Radon is a lung carcinogen for humans, classified in Group I in the classification of the International Agency for Research on Cancer (IARC). According to estimates undertaken by the French Institute for Public Health Surveillance (InVS), between 1200 and 2900 deaths from lung cancer are attributable each year to indoor radon exposure in France, which correspond between 5% and 12% of deaths lung cancer observed in France.

These figures should be compared with estimates for other risk factors. For example, for 1999, it was estimated that approximately 2000 and 4200 lung cancer deaths were attributable to occupational exposure to asbestos.

In France, the management of risk from radon exposure into buildings started in 1999 with the first recommendations for public buildings located in areas identified as priorities.



31 French priority departments

Since 2004, the regulatory framework on the management of the radon risk, fixed management methods in public places such as schools, including buildings internship, health and social institutions, spas and jails. The owners of these establishments are obliged, when they are located in one of the 31 priority departments, to make measurements of radon activity concentration and, if necessary, to implement the necessary measures to reduce the occupant exposure.

Measurements of radon activity concentration are carried out by bodies approved by the French Nuclear Safety Authority (ASN).

In 2007, the management of the radon risk is extended to workplaces. The Labour Code has introduced various improvements of existing rules protecting workers against ionizing radiation from natural sources. It requires that, in the underground workplaces where some defined activities are exercised, and situated in the priority areas, the employer has to carry out measurements of radon activity concentration by an approved body. The regulatory system has been fully operational since late 2009.

Finally, a law dating from July 2009 completed the legislative provisions of the Code of Public Health for the management of the radon risk in extending the requirement to measure the radon activity concentration in other categories of buildings. The law should allow an extension of the regulatory framework including residential buildings. The decree law enforcement, in preparation, will include the maximum level of radon activity concentration above which it is necessary to reduce exposure to radon and categories of buildings affected by these new provisions.

Also in line with the National Plan for Health and the Environment (PNSE) and to meet the demand of European Directive Euratom, France has developed National Plans of Action against Radon. The first plan implemented (2005-2008) allowed in the one hand, the implementation of important measures for radon risk prevention and in the other hand a close collaboration between the different actors involved in radon issue.

Currently, a second action plan is underway (PAR 2011-2015). The plan developed is the result of collaboration between the ASN and the Ministries of Housing, of Health and of Labour, and with the support of public research centers such as the Institute of Radioprotection and Nuclear Safety (IRSN), the Scientific and Technical Center for Building (CSTB), the InVS and organizations and regional authorities.

The major focuses of the second plan are:

- To establish a policy on radon risk management in existing buildings for residential use,
- To develop regulations for new buildings,
- To follow the efficiency of the regulation stated for existing public buildings and for working places.
- To develop and to implement new management tools and operating device for performing building diagnostics and construction work for building professionals
- To coordinate policy studies and research

The Scientific and Technical Center for Building (CSTB) is an independent French public institution dedicated to innovation into building. It is an industrial and commercial public research center known in France as an EPIC. It is placed under the joint supervision of Ministry of Housing and the Ministry of Sustainable Development. It has a workforce of around 950 employees. CSTB works on the improvement of comfort and safety in buildings and their environment in three complementary areas: research and consultancy, quality evaluation and knowledge dissemination. CSTB fields of expertise are sustainable development, safety and risk prevention, construction quality, structure optimization, housing and urban development, information technology. CSTB has a long experience in dealing with National and European activities and an research projects.

The Health and Buildings (HB) Division at CSTB has a staff of 30 permanent (including 8 senior scientists). The HB division is dealing with research and consulting in the various fields interfacing buildings and health, and is more particularly the technical and scientific coordinator of the indoor air quality observatory (OQAI). It develops particular expertise in assessing the indoor air quality through numerical and experimental research studies (laboratory, experimental house, in situ).

Referring to radon risk into building, CSTB works for many years in the building protection. CSTB provides scientific and technical support to the government. It contributes to various actions listed in the National Radon Action Plan. It develops for many years expertise in the field of building protection development and improvement through standardization activities, applied research and supporting actors of the building. It also participates in European actions on the subject.

Different field and experimental studies had been undertaken to ameliorate and asses the performances of building protection systems:

- Analysis of efficiency and cost of remedial actions in existing buildings,
- Test of feasibility of Soil Depressurization Systems and dimensioning
- Study on Passive Soil Depressurization System
- Use of ventilation system to prevent radon income
- Impact of thermal rehabilitation on radon exposure
- Elaboration of a short term in-situ methodology to assess radon potential in buildings

Main results of these studies will be summarized in this presentation.

Some available publications on these subjects are listed below.

Scientific Journals

- Radon remediation and prevention status in 23 European countries. O. Holmgren; H. Arvela; B. Collignan; M. Jiranek; W. Ringer. Radiation Protection Dosimetry 2013; doi: 10.1093/rpd/nct156
- Development of a methodology to characterize radon entry into dwellings. Collignan B., Lorkowski C., Améon R. Building and Environment 57, 176 – 183, November 2012.
- Experimental study on passive Soil Depressurisation System to prevent soil gaseous pollutants into building, Abdelouhab M, Collignan B, Allard F. Building and Environment 45, 2400 – 2406, May 2010.

International conferences:

- Development of an air flow model for passive Soil Depressurization System design to protect building against radon. T.M.O. Diallo, B. Collignan, F. Allard. 7th International Conference on Protection Against Radon at Home and at Work. 2nd – 6th Sept. 2013. Prague. Czech Republic.
- The Effect of New Building Concepts on Indoor Radon. W. Ringer, J. Gräser, H. Arvela, O. Holmgren, B. Collignan. IRPA 13, Glasgow, Scotland, 13 – 18 May 2012
- Basement Depressurisation using dwelling mechanical exhaust ventilation system. Collignan B., O'Kelly P., Pilch E. 4th European Conference on Protection against radon at home and at work. Praha, 28th June – 2nd July 2004.
- Dimensioning of soil depressurization system for radon remediation in existing buildings. Collignan B., O'Kelly P. Proceedings of ISIAQ 7th International Conference Healthy Buildings 2003, Singapore, 7th – 11th December 2003, Vol. 1, pp 517-523.

Radon mitigation in Slovenia

Friderik Knez, (ZAG Ljubljana¹)

Summary

In the paper experience in radon mitigation in Slovenia is presented with the emphasis on different failure reasons. Practical side of the mitigation is considered. Although the paper does not deal with full description of different mitigation systems employed general information on techniques and their effectiveness is given. All employed systems are SSD (sub-slab depressurization) type. Cases with unexpected results are also considered.

1. Introduction

History of systematic radon risk awareness and mitigation in Slovenia is about 25 years long. Earlier radon research and papers exist but they are limited to individual cases. The approach effectively begun with 5 year national program of measurements that included 730 kindergartens, 890 primary schools and 1000 apartments. Afterwards additional measurements were done over time. The number of schools is rather high – today there are 450 primary schools registered in Slovenia, many have more than one building. Thus one could claim virtually full coverage in primary schools. On the other hand 1000 dwellings is a

respectable sample but it represents much smaller portion of the full stock that comprises approximately 600.000 buildings – 500.000 of them being individual buildings.

Spatial distribution of higher risk is not uniform across Slovenia due to different geological conditions. Karst terrain presents higher risk and is found in southern Slovenia. On the other hand individual buildings are smaller areas are also identified with higher risk in cases where buildings are built on compacted fly ash ground. These cases are more seldom and are found mainly in vicinity of major railway stations or in vicinity of steel factories.

2. Radon mitigation

Over the years ZAG has been involved in radon mitigation in about 20 cases. Most of the cases were triggered by alarmingly high measurements in schools found in previously mentioned study. As a rule average concentrations before mitigation by far exceeded 1000 Bq/m³. Mitigation was considered successful if concentrations after the mitigation were less than 400 Bq/m³. In the following text some interesting cases, important for understanding of whole approach are described. The cases are summarized in the Table 1 and are shown schematically on Figure 1 and Figure 2.

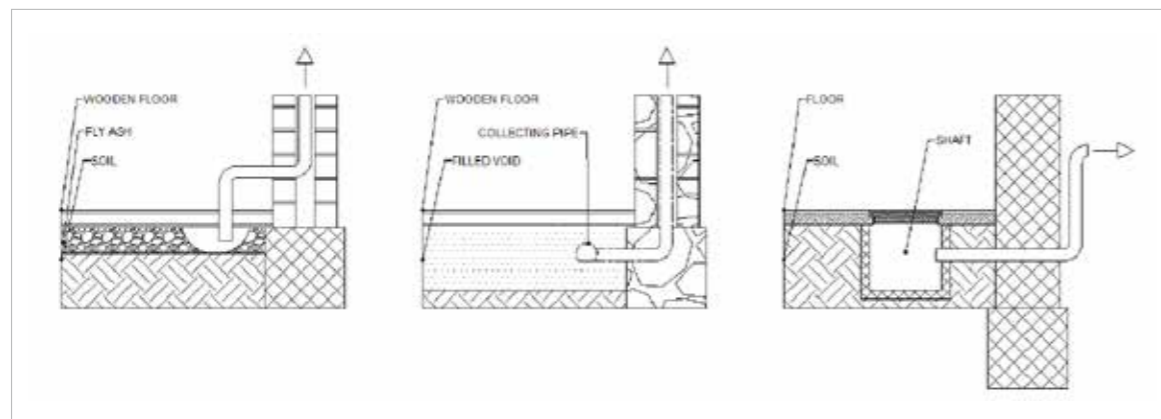

Figure 1: Schematic of different mitigation approaches (history cases) used in cases #1, #2 and #3.

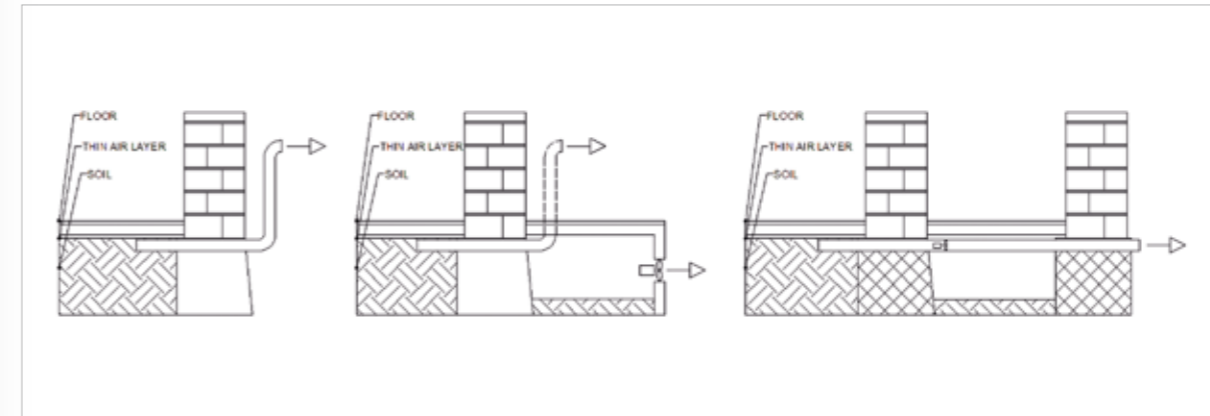

Figure 2: Schematic of different mitigation approaches (new cases) used in cases #4, #5 and #6.

#	Building	Basic building description	Radon source	C _{Rn,initial} [Bq/m ³]	C _{Rn,inter} [Bq/m ³]	C _{Rn,mit} [Bq/m ³]	Mitig. [year]	Mitig. principle
1	Janče	Wooden floor, fly-ash in the structure.	Fly ash in the floor structure	Over 1.000	less than 400	-	1997	SSD
2	Lokev pri Sežani	Wooden floor, beneath large void (estimated 1,5 m ³ /m ² floor)	Soil	> 1.000	200-850	-	1997	New floor, SSD
3	Dolenja vas	Concrete floor, long shaft network (piping, sewage)	Soil, radon distributed by shafts	600-4.150	100-3.165	< 100 - 500	1997	Ventilation of shafts + SSD (part)
4	Prevole	Concrete, inaccessible walls	Soil	3.200	Not yet avail.	-	2012	SSD
5	Muljava	Concrete floor on ground, under floor suspected mixed debris	Soil	4.000	380	-	2011	SSD
6	Vavta vas	Concrete (?), stone walls, under floor suspected debris	Soil	1.750	340	169	2013	SSD, sealing

Table 1: description of studied cases; C_{Rn,initial} stands for average radon concentration before mitigation, C_{Rn,inter} stands for average radon concentration after first mitigation before correction and C_{Rn,mit} stands for final mitigated average radon concentration. Exact values in cases #1, #2 and #3 are incomplete.

3. History cases and new cases

Most of history cases are not very well documented. However common approach has been used in all mitigation cases from the first period. The cases are described in items #1, #2 and #3 in Table 1. This approach was based on EPA guidelines always involving a form, usually modified sub-slab depressurization (SSD). In some cases SSD was assisted by e.g. shaft ventilation. New cases are listed as cases #4, #5 and #6. These have been executed recently.

Case #1: the floor was old and incorporated loose fly-ash. Some fly-ash was also in tampon layer as well. Lower part of floor structure was wooden, permeable. In diagnostics process pressure field extension was verified and estimated as sufficient for SSD with 1 radon pit. The pressure field was extended across whole school thanks to relatively permeable tampon layer. The system employed was active, piping through the old chimney to the roof. The ventilation system was effective. Side effect of the system was significantly drier wooden structure leading to minor wood shrinkage and cracks.

Case #2: the floor structure was wooden, inspection revealed no pressure field extension and later large void in contact with soil was found. It was decided that the floor structure was not suitable for SSD thus new floor structure was constructed with collector pipe system. Chimney was used for vertical communication. The system was active, however at first inadequate fan (bathroom type) was used and later replaced with axial fan.

Case #3: in radon concentration measurements it was established that in main building radon originates from the soil and is concentrated in shafts. It was also established that this is by far most intensive route. Therefore ventilation system for shafts was used and shaft lids were resealed or closed permanently. In adjacent building radon was entering the rooms through concrete slab; SSD was executed in that room and floor sealed with aluminum foil. While SSD is proven successful and is still running the foil was proven to be a bad choice due to moisture transport. Tight foil caused floor swelling and was thus removed. Now system is running as pure SSD system.

Case #4: source of radon is soil (concentration of radon in soil was measured over 100.000 Bq/m³). The floor structure is concrete, beneath the floor there is a layer of mixed stone aggregate. Given the structure an SSD was designed that would enter the aggregate layer horizontally. The SSD system was supposed to be executed by local contractor. However he failed to comply with the design and has critically altered the design without consulting us, first. Instead of a proper SSD system he has linked the layers under the concrete slab with closed storage room in-front of the wall. In these rooms originally piping should have been mounted. Then he has installed fans to ventilate these rooms. Due to poor understanding of principles he also created openings to allow for air-flow into the rooms. The fans create some under-pressure in the closed storage rooms but extension of the pressure field is very questionable. Since the owner has already ordered measurements of radon concentration it is decided to wait and see the effect of the SSD, although predicted insufficient.

Case #5: the floor structure is made of concrete. Underneath the structure soil was not known. Pressure field extension was extremely difficult to establish and is assumed low. Nevertheless SSD was attempted as thin air layer was expected just beneath the ground slab. The system was properly executed by local contractor and measurements have proven sufficient effect. The case is a proof that by following the design SSD can work in almost all cases.

Case #6: the floor structure is made of concrete. Part of the building's walls exhibit wide crack in the target area of mitigation. Selected mitigation strategy was SSD. To that purpose a pilot system was installed in the cellar, accessing the layer to be ventilated. The results however did not support the effectiveness. The reason is not known but mentioned crack might have short-circuited the depressurization system. In order to resolve the issue another system was installed, again accessing permeable layer. The system on second spot was proven to be effective. However concentration in one room did not drop sufficiently. It is a room directly above the cellar. Inspection has shown that the floor is not tight enough. Because floor in cellar is not suitable for SSD/SMD sealing with liquid waterproofing system was proposed, but not yet done.

4. Follow-up

Lately there has been a follow-up activity to revisit mitigated sites. Some very valuable information was gained pointing out some unexpected risks and difficulties in provision of long-lasting solutions. These are described as follows. Risk 1: unauthorized interventions: Common problem with durability of radon mitigation solution is that in most of the cases additional interventions were done. Most of them are due to energy efficiency measures and due to adaptation of building. None of such cases was verified with original system designers. Due to lack of understanding of the radon mitigation system this was either removed or seriously hindered.

Risk 2: failure to operate system properly: In case #2 the radon mitigation system was properly executed. However instructions for use were not respected. The system was not operated continuously. The result was decrease of concentration with a phase-shift. Proper operation was again explained to the staff.

Risk 3: failure to comply fully with instructions for system execution: In some cases (#3 and #4) the radon mitigation system was improperly executed due to lack of understanding of the purpose of individual components. The mechanical engineer could not understand there is a need for under-pressure but not for air-flow. The result: additional openings close to the fan largely decreased under-pressure field extension. The mitigation result was negative, the concentrations remained virtually unchanged. After the intervention and closing of the openings the concentrations were measured again and were found at target level of around 100 Bq/m³.

Risk 4: users rely on mitigation system without further measures: In case #6 the user of the building does not feel any need for further considering concentration monitoring. He relies completely on set of system confirmation measurements (not intended to establish radon concentration relevantly), done in mitigation phase, which is not appropriate.

5. Conclusion

It is essential that radon mitigation is done, if possible, in one operation from measurement of radon concentration to final mitigation system execution and verification. It was clearly shown that the effectiveness of radon mitigation system in Slovenia largely depends on early involvement of system installer, which is sometimes difficult due to different reasons.

It is also essential that the system is monitored by professionals periodically and that clear warning is given against any intervention in the building without consulting the experts. Although this might seem obvious and easy to do it might not be easy after 10 or 20 years of operation of the system. The same is true for operation of the system – education on nature and use of the system is very important.

Thirdly – also surveillance by authorized body is necessary in order to avoid shortcuts in execution or operation of the system. This is especially true if awareness of radon risk is low.

Finally – if properly executed relatively simple systems can successfully mitigate radon.

References

- [1] Radon and Real Estate, EPA, <http://www.epa.gov/radon/realestate.html>, accessed 23. 11. 2013
- [2] Poro ilo o stanju v okolju (2002), ARSO, 2002, <http://www.arso.gov.si/>, accessed 23. 11. 2013

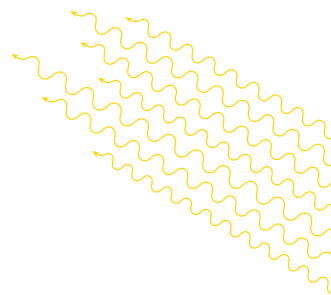

Finnish experiences in radon prevention in new construction and energy saving constructions

Olli Holmgren and Hannu Arvela

Radiation and Nuclear Safety Authority – STUK, P.O. Box 14, 00881 Helsinki, Finland

Introduction

Elevated radon concentrations in indoor air are normally caused by the convective flow of radon-bearing soil air. Due to the high radon concentration in soil air, typically 10 000–100 000 Bq/m³, even very low leakage air flows of 0.1–1 m³/h (0.03–0.3 l/s) can raise indoor radon concentrations above the reference level of 200 Bq/m³.

Convective leakage flows are created by the indoor–outdoor pressure difference. Soil air flows into indoor spaces through gaps, cracks and openings in the base floor. Two mechanisms create the pressure difference: first, natural forces such as the indoor–outdoor temperature difference and wind, and second, forced mechanical ventilation. Typical pressure differences created by the indoor–outdoor temperature difference range from 0–3 Pa (pascal).

Slab on ground is by far the most prevalent base-floor type for newly-constructed low-rise residential houses in Finland, accounting for 65% of houses. The key feature of this base-floor type regarding radon prevention is the gap between the floor slab and foundation wall (Figure 1).

This gap promotes the flow of radon-bearing soil air into living spaces. When taking into account the leaking foundations of semi-basement houses and basement houses, altogether 80% of Finnish low-rise residential buildings represent a foundation and base-floor type with a high radon risk. Preventive measures in new construction are thus an essential part of attempts to reduce radon concentrations in Finnish housing.

Regulations and guidance

The Finnish building code for radon prevention and the associated practical guidelines were revised in 2003 to 2004 (Building Information Ltd. 2003, Ministry of environment 2004). In the building code it is written that "In the design and construction work, radon risks at the construction site shall be taken into account." The indoor radon concentration must be below 200 Bq/m³. A radon-technical design may be left out only in case the local radon surveys clearly show that the radon concentration inside residential buildings is consistently below the permitted maximum value. To study the effect of the new regulations, STUK carried out a random sample survey of new construction in 2009 (Arvela et al. 2012).

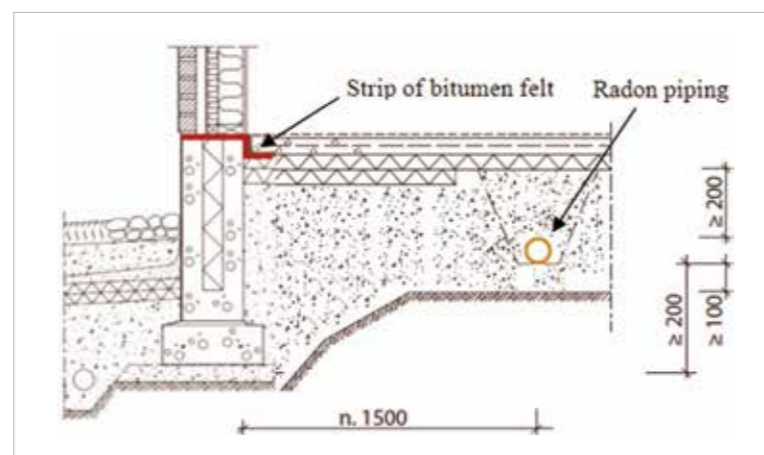

Figure 1. Sealing of the gap between the foundation wall and floor slab, and installation of radon piping according to the Finnish radon prevention guidelines. Image from RT 81–11099 (Building Information Ltd).

The revised guidance for radon-resistant new construction focuses on practices needed in houses with slab on ground as well as in houses with walls in contact with soil. The preventive measures include a radon piping (a network of perforated drainage pipe) installed below the floor slab and sealing of the joint between the floor slab and the foundation wall using a strip of bitumen felt (Figure 1). The discharge of the radon piping is lead open above roof. The temperature difference and wind create an air flow to the exhaust duct, which reduces the radon concentration in the pore air of the sub-slab gravel. When needed, one can install a fan on the exhaust duct which, when active, effectively reduces the indoor radon concentration.

Energy saving construction

The new practices of low-energy construction require improved thermal insulation, high air tightness and the implementation of mechanical supply and exhaust ventilation (MSEV) with heat recovery. Practically all new construction in Finland is presently provided with MSEV due to the demands for energy conservation. Simultaneously, the air tightness of newly build houses has been increasing, typical ACH50 values being already 1–4 h⁻¹. However, the number of actual passive houses is still small in Finland. The effect of air tightness and pressure differences on the indoor radon concentration in houses with different ventilation strategies have been studied in detail in (Arvela et al. 2013) through calculations, modelling and experimental studies.

Results

Based on the new construction survey, the average radon concentration of new houses, completed in 2006 to 2008, was 95 Bq/m³, the median being 58 Bq/m³, Table 1. The average was 33% lower than in houses completed in 2000 to 2005. The decrease was 47% in those provinces with the highest indoor radon concentrations and 26% elsewhere

in the country. The decrease compared to houses completed in 1980 to 1999 was more than 40%, Figure 2. The percentage of houses exceeding the reference level of 200 Bq/m³ had also markedly decreased, from 16% to 11%. In high radon provinces, the percentage was decreased from 42 % to 16.5 %.

Radon concentrations were by far the lowest in houses with a reinforced uniform floor slab and those with a crawl space. In both of these classes, the average radon concentration was below 45 Bq/m³ and the median below 30 Bq/m³. In houses with a slab on ground, the average was 96 Bq/m³ and the median 68 Bq/m³. In semi-basement and basement houses with block walls in contact with soil, the average and the median were 151 Bq/m³ and 100 Bq/m³, more than 50% higher than in houses with a slab on ground. The main reason for these elevated values is the defective measures for radon prevention in the block walls made of lightweight aggregate concrete. Leakages of radon-bearing soil air through the block walls in contact with soil can also be seen in the percentage of houses exceeding the reference level of 200 Bq/m³. This figure was 22 %, as compared to 11 % for single family houses with slab on ground.

Preventive measures had been carried out in 54% of single family houses with slab on ground. The percentage was 92% in the six provinces with the highest indoor radon concentration (Zone 1) and 38% elsewhere in the country (Zone 2 in Table 1). Nationwide, the new regulations issued in 2003 to 2004 have doubled the level of prevention activity.

The effectiveness of preventive measures was assessed through a comparison of indoor radon concentrations in houses with prevention compared to those where no preventive measures had been taken. In this comparison, local reference values from the indoor radon database, including 87 000 houses throughout Finland (Valmari et al.

2010), were utilized. The details can be found in (Arvela et al. 2012). In single family houses with slab on ground, passive radon piping and the installation of a strip of bitumen felt reduced the indoor radon concentration by 55%. The average reduction for radon piping with no sealing measures was 40%.

The effect of ventilation strategies on radon concentration was examined using the STUK's radon measurement database (Arvela et al. 2013). The data for houses constructed in 1985–1994 was used in order to obtain a homogeneous data set. Radon concentration in total of 5312 houses was analysed. The result was such that the use of MSEV reduced radon by 30 % compared to houses with natural ventilation.

MSEV makes it possible to control the pressure difference using balanced ventilation. In practice, in countries where fully balanced ventilation is recommended, slight positive or negative pressures (i.e. unbalance) exist in living spaces due to inaccuracies and variation in air flow adjustments and measurements. The results of our study (Arvela et al. 2013) indicate that in an airtight MSEV house with ACH50 <math>< 1 \text{ h}^{-1}</math>, pressure differences from 1–10 Pa may occur when 10 % difference between supply and exhaust air exists. When the typical natural pressure differences due to the indoor–outdoor temperature difference are 1–3 Pa, these additional pressure differences created by the ventilation system and high air tightness markedly increase the flow of radon-bearing soil air into living spaces if there are any gaps in the base floor.

Conclusions

According to the results of the new construction survey, there is high variation in the prevention activity in different areas of the country. Local authorities require prevention measures commonly in those areas with the highest radon concentrations, which has also resulted in a considerable decrease in indoor radon concentrations. On the other hand, in those areas where no prevention has been taken, indoor radon concentrations have remained as before or have even increased. Radon-resistant new construction practices represent economic investments. The effect of preventive measures is so significant that installation of the passive radon piping and bitumen felt is recommended throughout the country. Builders should require architects and all participants in building projects to implement radon prevention measures according to the current guidelines. After completion of the new house, it is important to measure the radon concentration to confirm the low radon level. If radon concentration is above the reference level, it is easy to activate the radon piping with a fan.

Table 1: Average and median radon concentration and percentage of houses exceeding 200 Bq/m³ in the new construction survey (2009) for the six provinces of Finland with the highest radon concentration (Zone 1) and elsewhere in the country (Zone 2). Comparison with the winter measurement of the nationwide sample survey (2006) (Mäkeläinen et al. 2010).

Survey and region	Radon concentration (Decrease in levels in the new construction survey, compared with the sample survey (2006), % or percentage points, pp)					
	New construction survey (2009)			Sample survey (2006), winter meas.		
	Average Bq/m ³	Median Bq/m ³	Percentage >200 Bq/m ³	Average Bq/m ³	Median Bq/m ³	Percentage >200 Bq/m ³
Zone 1	125 (47%)	74 (55%)	16.5 (25 pp)	237	166	41.9
Zone 2	83 (26%)	53 (28%)	8.4 (3.8 pp)	112	74	12.2
Whole country	95 (33%)	58 (33%)	10.6 (8.8 pp)	142	87	19.4

Zone 1: Provinces of Itä-Uusimaa, Kymenlaakso, Päijät-Häme, Pirkanmaa, Etelä-Karjala and Kanta-Häme;
Zone 2: Other provinces

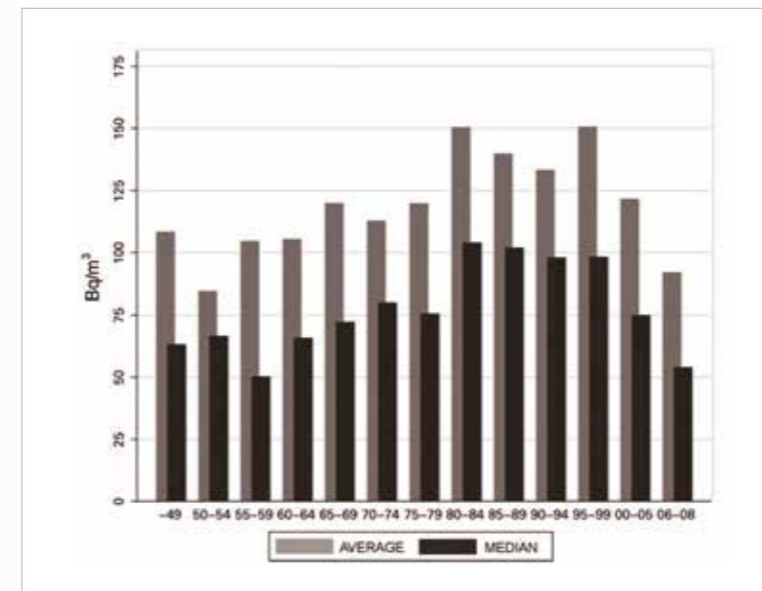

Figure 2. Radon concentration in low-rise residential houses according to the year of construction based on the national Finnish sample survey in 2006 (1949–2005). The last bar (2006–2008) represents the results of the new construction survey (2009).

The requirement for radon prevention in connection with the application for building permission and the widespread and skilled implementation of preventive measures throughout the country could result in an average of 50% reduction in indoor radon concentrations compared to the present housing stock with no prevention. This would considerably reduce exposure to radon and the harmful health effects of indoor radon in the coming decades.

The aims towards high air tightness are synergetic for radon prevention and low energy construction: the base floor and foundation constructions should be carefully sealed. On the other hand, due to the interaction of mechanical ventilation and high air tightness, the pressure difference in buildings can be markedly enhanced in some cases. This may lead to elevated indoor radon levels if there are minor leakages in the base floor. The minor leakages can affect the radon concentration, even in cases where the leaks do not markedly reduce the total air tightness. The potential for high negative pressures considerably increases when the air tightness ACH50 is below 1.0 h⁻¹. This is a challenge for efficient radon prevention in new construction. Guidelines for ventilation adjustment in MSEV houses may also need revision.

References

- Arvela H., Holmgren O., Reisbacka H. (2012) Radon prevention in new construction in Finland: A Nationwide sample survey in 2009. *Radiation Protection Dosimetry* (2012), 148 (4): 465–474; doi: 10.1093/rpd/ncr192.
- Arvela, H., Holmgren, O., Reisbacka, H. and Vinha, J. (2013) Review of low-energy construction, air tightness, ventilation strategies and indoor radon: results from Finnish houses and apartments. *Radiation Protection Dosimetry* 2013, doi:10.1093/rpd/nct278.
- Building Information Ltd. (2003) Radon Prevention, RT 81–11099 (LVI 37–10513). Helsinki (2003). (In Finnish)
- Ministry of Environment. (2004) Foundations, Regulations and Guidelines 2004. The National Building Code of Finland. Part B3. Helsinki (2004).
- Mäkeläinen I, Valmari T, Reisbacka H, Kinnunen T, Arvela H. (2011) Indoor Radon and Construction Practices of Finnish homes from 20th to 21st century. Proceedings of the third European IRPA congress, 14–18 June 2010, Helsinki, Finland, pp 561–569. STUK/NSFS, electronic publication 2011.
- Valmari, T., Mäkeläinen, I., Reisbacka, H. and Arvela, H. Suomen radonkartasto 2010. Radonatlas över Finland 2010. Radon Atlas of Finland 2010. Report STUK-A245. Radiation and Nuclear Safety Authority. Helsinki 2010. ISBN 978-952-478-537-2. www.stuk.fi.

Baupraxis betreffend Radon in Österreich – Regelungen, Erfahrungen und Zukunftsausblick

Dipl.-Ing. Julia Karimi-Auer

Amt der Steiermärkischen Landesregierung Abteilung 15 – Energie, Wohnbau, Technik,
Fachabteilung Energie und Wohnbau, Graz

In diesem Artikel zur Baupraxis betreffend Radon in Österreich werden folgende Themenbereiche beleuchtet:

- Baugesetzliche Rahmenbedingungen
- Bautechnische Grundlagen
- Erfahrungen und Ausblick

Baugesetzliche Rahmenbedingungen

Das Baurecht in Österreich befindet sich im Kompetenzbereich der neun österreichischen Bundesländer. Daraus ergibt sich die Situation, dass bei einer Einwohnerzahl von rund 8,5 Millionen neun verschiedene Baugesetze mit jeweils von einander abweichendem Verfahrensrecht und ebenso abweichenden bautechnischen Bestimmungen nebeneinander stehen können.

Beginnend ab 1948 wurde mehrfach der Versuch unternommen, insbesondere für die bautechnischen Bestimmungen eine Harmonisierung (Vereinheitlichung) in Österreich herbeizuführen. Erst im April 2007 führten diese Bestrebungen erstmals zu einem Erfolg, nämlich als sechs bautechnische Richtlinien, die sogenannten OIB¹-Richtlinien, als ein harmonisiertes bautechnisches Regelwerk veröffentlicht wurden. Diese OIB-Richtlinien dienen als Basis für die Harmonisierung der bautechnischen Vorschriften in den österreichischen Bundesländern und können von diesen freiwillig zu diesem Zweck herangezogen werden. Die Erklärung einer rechtlichen Verbindlichkeit der OIB-Richtlinien ist den Bundesländern vorbehalten. Zwischenzeitlich haben sieben von neun Bundesländern die OIB-Richtlinien als bautechnische Bestimmungen in das jeweilige Baurecht übernommen und haben damit dem Harmonisierungsgedanken Rechnung getragen (Vorarlberg, Tirol, Kärnten, Steiermark, Burgenland, Wien und Oberösterreich). Lediglich die Bundesländer Niederösterreich und Salzburg haben ihre eigenen, landesspezifischen bautechnischen Bestimmungen beibehalten.

Dieser Entwicklungsprozess ist für das Thema des baulichen Radonschutzes von besonderer Relevanz, da in den

OIB-Richtlinien erstmals Bestimmungen zur bautechnischen Radon-Vorsorge enthalten sind. So wird in der OIB-Richtlinie 3 betreffend Hygiene, Gesundheit und Umweltschutz, Stand Oktober 2011, in Pkt. 8.2 folgendes geregelt:

„Aufenthaltsräume sind so auszuführen, dass keine die Gesundheit der Benutzer beeinträchtigende ionisierende Strahlung aus Baumaterialien und Radonemission aus dem Untergrund auftritt. Hinsichtlich der ionisierenden Strahlung aus Baumaterialien gilt dies jedenfalls als erfüllt, wenn Bauprodukte bestimmungsgemäß verwendet werden, die die landesrechtlichen Vorschriften über Bauprodukte erfüllen.“

In jenen sieben österreichischen Bundesländern, die die OIB-Richtlinien als bautechnische Bestimmungen in die Baugesetzgebung übernommen haben, ist die oben angeführte Bestimmung betreffend Radon rechtsverbindlich einzuhalten. Die angeführten Anforderungen bezüglich eines baulichen Radonschutzes gelten grundsätzlich für Neubauten und auch Nutzungsänderungen, nicht aber für Bestandsbauten. Zur Klärung der Frage, wie ein baulicher Radonschutz nach der obigen Bestimmungen auszusehen hat, ist in Österreich auf bautechnische Regelwerke wie zum Beispiel die ÖNORMEN-Serie S 5280 zurückzugreifen. Darauf wird im folgenden Kapitel „Bautechnische Grundlagen“ näher eingegangen.

Bautechnische Grundlagen

Bereits seit mehr als zehn Jahren existiert die ÖNORMEN-Serie S 5280² mit dem Titel „Radon“. Diese Normenserie gliedert sich derzeit in drei Teile:

Teil 1: Messverfahren und deren Anwendungsbereiche (Ausgabe 2008-05-01)

Teil 2: Technische Vorsorgemaßnahmen bei Gebäuden (Ausgabe 2012-07-15)

Teil 3: Sanierungsmaßnahmen an Gebäuden (VORNORM – Ausgabe 2005-06-01)

Aus bautechnischer Sicht sind insbesondere Teil 2 und Teil 3 von Interesse.

In Teil 2 werden Maßnahmen bei Neubauten in Abhängigkeit der Radonpotentialklasse geregelt. Die Regelung erfolgt über ein einfach abzuarbeitendes Flussdiagramm, das im Wesentlichen folgenden Schluss zulässt:

Zusätzlich zu einer dem Stand der Technik entsprechenden Bauwerksabdichtung gegen Feuchtigkeit und Wasser als stets anzuwendende und ausreichende Grundmaßnahme sind in folgenden Fällen Maßnahmen erforderlich:

- Gebäude verfügt über kein baulich abgetrenntes Kellergeschoß oder keinen belüfteten Kriechkeller
- Aufenthaltsräume befinden sich im Keller
- Bauwerk liegt in der Radonpotentialklasse 2 oder 3 (d.h. Radonpotential der Gemeinde mindestens 200 Bq/m³)

Die erweiterten Maßnahmen zur baulichen Radonvorsorge sind in der ÖNORM S 5280-2, Radon – Teil 2: Technische Vorsorgemaßnahmen bei Gebäuden, beschrieben (z.B. Ausführung einer Unterbodenabsaugung / Radondrainage). Die Wirksamkeit von getroffenen, baulichen Vorsorgemaßnahmen sollte bei einem Radonpotential der Gemeinde von 200 Bq/m³ und mehr nach Ausführung der jeweiligen Maßnahme durch Radon-Messungen überprüft und bestätigt werden.

Bezüglich baulicher Maßnahmen für den Radonschutz in Bestandsbauten wird auf den Teil 3 der Normenserie verwiesen. Dieser Normenteil liegt derzeit noch als Vornorm auf und soll 2015 neu aufgelegt werden. Zur baulichen Radonsanierung nennt die Norm zehn verschiedene Methoden, die weitgehend auf Erfahrungen beruhen, die im Rahmen von nationalen Radon-Programmen in Österreich, den USA, Kanada, Schweden, Finnland, Großbritannien, der Schweiz, Südtirol und Deutschland gesammelt wurden. Bei diesen zehn Methoden handelt es sich um:

- Unterbindung des konvektiven Luftstroms zwischen Keller und den darüberliegenden Räumen



Rohrführung im Rahmen einer Unterbodenabsaugung über einen stillgelegten Abgasfang (Radonsanierung in einem Privathaus)

- Reduktion des infolge des Kamineffekts herrschenden Unterdrucks im Gebäude
- Erhöhte natürliche Belüftung unterhalb der Bodenplatte
- Unterbodenabsaugung (siehe auch Bild 1 und Bild 2)
- Mechanische Belüftung des Gebäudes
- Zwischenbodenabsaugung
- Erzeugung von Überdruck im Gebäude (Kellergeschoß)
- Verfüugung von Öffnungen, Rissen und Spalten bzw. Versiegelung von Flächen durch Anstriche oder Beschichtungen
- Abschirmung des Untergrundes durch Injektionsschirme

Darüber hinaus beschreibt die Vornorm ÖNORM S 5280-3 detailliert, wie bei einer baulichen Radon-Sanierung vorzugehen ist (notwendige Erhebungen, Messungen und Maßnahmen).



Rohrführung im Rahmen einer Unterbodenabsaugung über einen stillgelegten Abgasfang (Radonsanierung in einem Privathaus)

Erfahrungen und Ausblick

Das Bundesland Oberösterreich, das bereits seit dem Jahr 1997 sowohl Radonsanierungen als auch Maßnahmen zum radonsicheren Bauen bei Neubauten finanziell fördert, nimmt diesbezüglich in Österreich eine Vorreiterrolle ein. Im Rahmen dieser Radonförderungen wurden in Oberösterreich seit dem Jahr 1997 67 Neubauförderungen und 55 Bestandsförderungen durchgeführt. Bei Bestandssanierungen wurde vielfach und erfolgreich die Methode der Unterbodenabsaugung angewandt, sodass im Rahmen dessen entsprechende Erfahrungen gewonnen werden konnten. Diese Erfahrungswerte werden in Zukunft ausgebaut werden können, da das radonsichere Bauen für Neubauten in Österreich nun fast flächendeckend gesetzlich

vorgeschrieben ist. Um diese neuen und bisher nicht dagewesenen Regelungen betreffend radonsicherem Bauen in der baubehördlichen Bewilligungspraxis zu verankern, wird dieses Thema in Rahmen von Schulungen für Bausachverständige vorgetragen.

Weitere Erfahrungen sind aus dem derzeit im Bundesland Steiermark laufenden Radon-Projekt zu erwarten. Bei diesem in Zusammenarbeit zwischen der AGES³ und dem Amt der Steiermärkischen Landesregierung abgewickelten Projekt wurden in drei Gemeinden der Steiermark Radonmessungen in rund 1000 Haushalten durchgeführt. Auf Basis der ausgewerteten Messergebnisse wird auch in der Steiermark eine finanzielle Förderung für Radonsanierungen eingerichtet werden.

Weiterführende Informationen

- OIB-Richtlinie 3 „Hygiene, Gesundheit und Umweltschutz“ betreffend baulichen Radonschutz: www.oib.or.at
- Allgemeine Informationen zu radonsicherem Bauen im Bundesland Oberösterreich: www.land-oberoesterreich.gv.at/thema/radon
- Bezug der ÖNORMEN-Serie S 5280 (Teil 1-3): www.on-norm.at
- Österreichweite Abfrage des Radonpotentials auf Gemeindebasis: www.radon.gv.at/radonsuche.html
- Allgemeine Informationen des Bundesministerium für Land- und Forstwirtschaft, Umwelt und Wasserwirtschaft: <http://www.lebensministerium.at/umwelt/strahlen-atom/strahlenschutz/radon/radonpotenzial.html>
- Rechtsinformationssystem des Bundes: www.ris.bka.gv.at

Über die Autorin

Julia Karimi-Auer hat das Studium des Bauingenieurwesens an der Technischen Universität in Graz abgeschlossen und danach etliche Jahre als Statikerin im Hoch- und Tiefbau sowie Projektleiterin im konstruktiven Wasserbau (Wasserkraftwerksplanung) gearbeitet. Seit 2005 ist sie als bautechnische Amtssachverständige und Referentin für bautechnische Fragen beim Amt der Steiermärkischen Landesregierung / Österreich tätig.

Kontakt: julia.karimi-auer@stmk.gv.at

Die Fotos stammen von der Autorin.

The approach of the Italian National Action Plan on radon for prevention in new buildings and mitigation in existing buildings and considerations on the effects of the forthcoming new European Directive

Francesco Bochicchio (ISS, Italy)

on behalf of the Working Group of the Italian National Radon Action Plan on Preventive Measures and Remedial Actions against Indoor Radon*

Introduction

The Italian National Radon Action Plan (INRAP) was prepared in 2002 by a working group of several experts and approved by the Ministry of Health. Its implementation started on 2005. The approach of the INRAP as regards prevention in new buildings and mitigation in existing buildings evolved from the original text of 2002, taking into account some main results of recent epidemiological studies, recommendations of the European project RADPAR (Radon Prevention and Remediation) (Bartzis et al, 2012), as well as approaches included in recent/forthcoming national and international regulations, including the WHO Handbook on Indoor Radon (WHO, 2009) and the European Directive on Basic Safety Standards which is expected to be approved in the next few months.

As regards the recent epidemiological studies on radon exposure in dwellings and in mines, the main results are the followings: i) a statistically significant increased risk of lung cancer can be observed for long-term exposures to relatively low values of radon concentration, i.e. for values not greater than 200 Bq/m³, which are relatively common in dwellings and workplaces (Darby et al, 2005); ii) the risk/exposure data are well described by a linear-no threshold function, and other functions (including function with a threshold) do not improve the data fit (Darby et al, 2005); the risk of lung cancer evaluated on the basis of recent epidemiological studies in mines resulted to be about two times higher than previous evaluations by ICRP which were the basis of international and national regulations up to few years ago (Tomasek et al, 2008).

As regards international and national recommendations and policies on radon, all the most recent ones (starting from the WHO Handbook on Indoor Radon, published in 2009) tend to require a higher protection of population and workers (Bochicchio, 2011), not limited to radon-prone areas, and to adopt lower reference levels for radon concentration.

The Italian National Action Plan and preventive measures in new buildings

The approach chosen within the INRAP as regards the preventive measures in new buildings is strongly related to the main long-term goal of the INRAP, which is the reduction of the health burden related to radon exposure. Moreover, it takes into account the elements reported in the Introduction.

On these basis it was decided that preventive measures – to reduce the ingress of radon from soil and to facilitate installation of post-construction systems to further reduce radon concentration – should be introduced in all the new buildings, contrary to the alternative approach to do it in selected areas only (i.e. in radon-prone areas), in order to maximize the radon health burden reduction. This approach has also a favorable cost-effectiveness. As a clear consequence of this approach, preventive measures should be introduced also in case of considerable building renewals involving soil-building interface.

In order to make this approach feasible in a large number of buildings, it is very important that the chosen preventive measures are not expensive and easy to be applied, i.e. not requiring training or specific knowledge on radon.

These contents were included in 2008 in a specific recommendation on this issue approved by the Scientific Committee of the Italian National Radon Action Plan (SC-INRAP, 2008). A similar recommendation was given in UK some months before the Italian one, also considering cost-effectiveness evaluation (UK-HPA, 2008).

This recommendation is intended to be formally implemented in regional building regulations and local building codes, and several Italian Regions and Municipalities has already adopted it, although a uniform adoption in Italy has to be obtained, yet. Such uniform adoption will probably result from the transposition of the forthcoming European Directive into the Italian national legislation, however it could be anticipated in the next few years.

In order to facilitate the implementation of the SC-INRAP recommendation, a guideline has been prepared by a working group within the framework of INRAP. This guideline, which is going to be published, contains eight cards/schemes, corresponding to the eight typical situations resulted from a classification of the building type in terms of presence of a crawl space (two options: yes/not) and in terms of position of the lowest rooms respect the ground level (four options: building with underground rooms; building with partially underground rooms, i.e. with basement; building with lowest rooms at ground level, and building lowest rooms above ground level).

Each card/scheme illustrates basic recommendations with the support of some drawings.

The basic goals of the illustrated preventive measures are: i) reduce the ingress of radon from soil, ii) facilitate installation of post-construction systems to further reduce radon concentration. The first goal is reached by means of both a barrier (a low-permeability membrane) installed below the lowest floor of the building and a passive ventilation system installed in the crawl space (if it is present) or in the sub-soil. The second goal is reached by preparing connections of the above cited ventilation system to an

active pump. Therefore each card/scheme illustrates two passive systems (a membrane + passive ventilation system) to reduce radon in every new building, as well as the position of the pump to be connected to the (crawl space or sub-soil) ventilation system in case, after construction, radon concentration needs to be further reduced.

As regards membranes, normal membranes (i.e. not specific for radon) are recommended, provided they have an adequate thickness and allow a good sealing.

The Italian National Action Plan and mitigation in existing buildings

As regards mitigation in existing buildings, at present there is no specific approach adopted in Italy.

A regulation is on force in Italy only for underground rooms of workplaces (including schools), so that most of the mitigated buildings are actually workplaces, typically schools. Moreover, the action level for workplaces in the current Italian regulation is 500 Bq/m³, so that the estimated number of workplaces with radon concentration exceeding the action level is relatively low.

However, the forthcoming European Directive on Basic Safety Standards will require that Member States adopt a maximum reference level of 300 Bq/m³ for both workplaces and dwellings, so that a much higher number of buildings are estimated to need mitigation in order to reduce radon concentration below the reference level that Italy will decide to adopt.

It could be difficult to develop a network of local building professionals trained and qualified in radon mitigation. In such cases, similarly to the approach adopted for preventive measures, the "normal" building professionals should be used also for radon remedial actions, provided that they receive operative instructions from professionals qualified in radon mitigation.

Some considerations on the effects of the forthcoming new European Directive

The forthcoming new Directive will represent a unique instrument to strongly improve the protection from radon in European countries. It is the first time that protection from radon in dwellings is included in an European directive – which has to be transposed into national legislation of Member States – and requirements on radon in workplaces have also significantly increased. Some flexibility has been introduced in the directive in order to allow Member States to take into account national circumstances. However, a transposition more protective than the basic safety standards is possible, as clearly specified in the directive.

It is desirable that transposition will occur (within the next four years, as required by the directive) at the highest protective level possible. Therefore, the experience gained in several countries should be used to the maximum extent. The recommendations produced within the RADPAR project (Bartzis et al, 2012), which resulted from an elaboration of such experience discussed among several European countries, could be a useful tool.

* Composition of the Working Group of the Italian National Radon Action Plan on Preventive Measures and Remedial Actions against Indoor Radon

The WG is composed by both radon and building experts.

In the first phase the following persons contributed to the WG: G. Torri (ISPRA, Roma, Italy) coordinator of the WG, F. Bochicchio (ISS, Roma, Italy) coordinator of the INRAP, C. Giovani (ARPA Friuli-Venezia Giulia, Italy), S. Innamorati (ISS, Roma, Italy), L. Minach (APPA Bolzano, Italy), A. Stefano (ISS, Roma, Italy), R. Trevisi (ISPESL, Roma, Italy), G. Zannoni (Univ. Ferrara, Italy).

In a second phase the following persons contributed to the WG: F. Bochicchio (ISS, Roma, Italy), S. Bucci (ARPA Toscana, Firenze, Italy), A. Stefano (ISS, Roma, Italy), M. Ciuffreda (Roma Municipality, Italy), C. Succhiarelli (Roma Municipality, Italy), C. Alimonti (Roma Municipality, Italy).

References

Bartzis J, Arvela H, Bochicchio F, Bradley J, Colligan B, Fenton D, Fojtikova I, Gray A, Grosche B, Gruson M, Holmgren O, Hulka J, Jiranek M, Kalimeri K, Kephelopoulos S, Klerkx J, Kreuzer M, McLaughlin J, Mueller S, Ringer W, Rovenska K, Schlesinger D, Venoso G, Zeeb H (2012). The RADPAR Recommendations. Report of the European project RADPAR (Radon Prevention and Remediation), 27 pp (available at <http://web.jrc.ec.europa.eu/radpar/documents.cfm>).

Bochicchio F. (2011) The newest international trend about regulation of indoor radon. *Radiat Prot Dosim* 146 (1–3): 2–5.

Darby S, Hill D, Auvinen A, Barros-Dios JM, Baysson H, Bochicchio F, Deo H, Falk R, Forastiere F, Hakama M, Heid I, Kreienbrock L, Kreuzer M, Lagarde F, Mäkeläinen I, Muirhead C, Oberaigner W, Pershagen G, Ruano-Ravina A, Ruosteenoja E, Schaffrath Rosario A, Tirmarche M, Tomá ek L, Whitley E, Wichmann HE, Doll R. (2005) Radon in homes and lung cancer risk: collaborative analysis of individual data from 13 European case-control studies. *BMJ* 330: 223–226.

EC (European Commission) (2013). Proposal for a Council Directive laying down basic safety standards for protection against the dangers arising from exposure to ionising radiation. (A version close to the expected final version can be found at the documents repository of the European Council, <http://register.consilium.europa.eu/pdf/en/13/st08/st08682-re02.en13.pdf>)

SC-INRAP (Scientific Committee of the Italian National Radon Action Plan) (2008). Recommendation on radon protective measures in all new buildings (in Italian). Available at www.iss.it/binary/tesa/cont/PNR_Raccomandazione.pdf.

Tomasek L, Rogel A., Tirmarche M., Mitton N., Laurier D. (2008) Lung cancer in French and Czech uranium miners: radon-associated risk at low exposure rates and modifying effects of time since exposure and age at exposure. *Radiat. Res.* 169(2), 125–137.

UK-HPA (United Kingdom-Health Protection Agency) (2008). HPA advice on radon protective measures in new buildings. 21 May.

WHO (World Health Organization) (2009). WHO Handbook on Indoor Radon: A Public Health Perspective. Geneva.

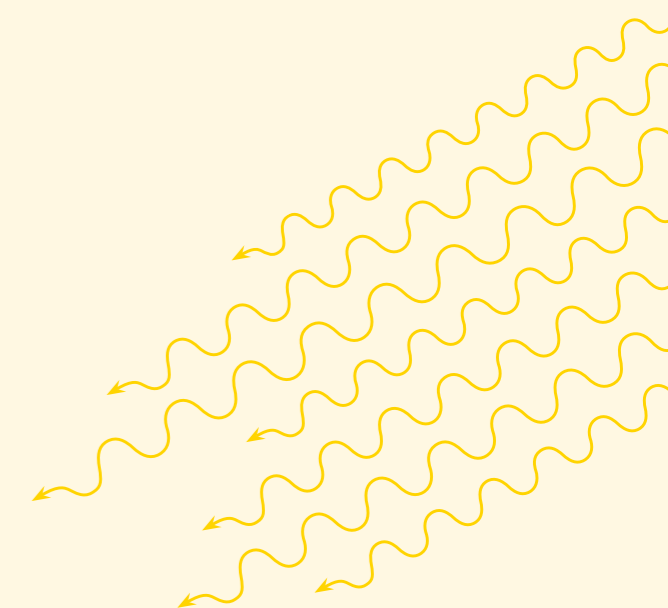

Berücksichtigung von Radon im Bewertungssystem Nachhaltiges Bauen

Dipl. Ing. Nicolas Kerz

Bundesinstitut für Bau-, Stadt- und Raumforschung

Referat II 5 Nachhaltiges Bauen

Hintergrund zu den Entwicklungen

Im Jahr 2008 entwickelte das Bundesministerium für Verkehr, Bau und Stadtentwicklung (BMVBS) in Kooperation mit der Deutschen Gesellschaft für Nachhaltiges Bauen (DGNB), einen ersten nationalen Satz an Nachhaltigkeitskriterien zum Ziele der transparenten sowie ganzheitlichen Bewertung von Gebäuden. Die Systementwicklung folgte dabei den aktuellsten Entwicklungen der europäischen Nachhaltigkeitsnormung und integrierte neben den wesentlichen drei Säulen der Nachhaltigkeit zusätzlich technische und prozessuale Fragen in insgesamt fünf Hauptkriteriengruppen.

Das aktuelle System umfasst für die Neubaubewertung insgesamt 40 Kriterien zur Bewertung der Gebäudequalität und sechs Kriterien zur Beschreibung der Standortmerkmale, darüber hinaus steht die Berücksichtigung des Gebäudelebenszyklus im Vordergrund.



Abb. 1: Logo des Bewertungssystems Nachhaltiges Bauen



Abb. 2: Bewertungssystem Nachhaltiges Bauen; www.bnb-nachhaltigesbauen.de



Abb. 3: Leitfaden Nachhaltiges Bauen, BMVBS 2013

In Adaption der gemeinsamen Arbeitsergebnisse, pflegt das BMVBS seit dem Jahre 2009 das Bewertungssystem Nachhaltiges Bauen (BNB) für Bundesgebäude (Abb.2). Entsprechend der aktuellen Erlasslage des BMVBS, ist der Leitfaden Nachhaltiges Bauen (Abb. 3) und damit verbunden das BNB als erforderliche Nachweismethodik für den zivilen Hochbau des Bundes verbindlich eingeführt worden. Für Verwaltungsneubauten, Unterrichtsneubauten sowie Komplettmodernisierungen von Verwaltungsgebäuden ab einer Investitionssumme von 2 Mio. Euro gilt, dass eine Gebäudebewertung mit abschließender Konformitätsprüfung im Mindeststandard Silber umzusetzen ist.

Derzeitige Adressierung von Radon im BNB

Wie können Gebäudebewertungssysteme wie das Bewertungssystem Nachhaltiges Bauen bei der Reduktion von Schadstoffen im Gebäude im Allgemeinen und im Speziellen bei geogenem Radon dienlich sein?

Das Bewertungssystem Nachhaltiges Bauen verfolgt das primäre Ziel, das Baugeschehen in seiner Ganzheitlichkeit „messbar“ hinsichtlich vereinbarter Nachhaltigkeitsanforderungen zu beschreiben und zu bewerten. Aufgrund der erreichbaren Qualitätsstufen kann es ein Anreizsystem für Bauherren, Planer, Nutzer sowie allen anderen Akteuren des Bauwesens darstellen. Das Bewertungssystem geht dabei über die gesetzlichen und normativen Regelungen deutlich hinaus.

Was bedeutet dies wiederum für den Bereich der Raumluftqualitäten?

Mit Beginn der Systementwicklung wurde die klare Entscheidung getroffen, dass die Thematik der Raumluftqualität im Zusammenhang mit Schadstoffemissionen aus Bauprodukten ein höherer Stellenwert beigemessen werden muss, als es die bisherige Regelungsdichte in Deutschland zulässt. Somit kann beispielsweise kein BNB-Zertifikat vergeben werden, wenn die Belastung der Raumluft durch flüchtige organische Verbindungen sowie Formaldehyd über die empfohlenen Grenzwerte hinausgehen. Zudem wurde wurden Qualitätsstufen definiert, nach denen das Gebäude eingestuft wird (Abb.4 und 5).

Für die verbindliche Messung und Bewertung geogenen Radons in der Raumluft fehlt derzeit noch eine vergleichbare Tabelle im Bewertungssystem Nachhaltiges Bauen. Das Wissen um die Thematik führte unter anderem dazu, dass in einem ersten Schritt die Qualität der Lüftungsrate – im Kriterium die zu ermittelnde Personenlüftungsrate – eine Stellvertreterfunktion übernehmen musste.

Nachhaltige Gebäude mit sehr guten Endbewertungen, verfügen in der Regel über hohe personenbezogene Lüftungsraten, die weitestgehend nur durch kontrollierte Lüftung zu erreichen sind. Gleiches Vorgehen erfolgt im Bereich der technischen Qualität des Gebäudes bei der Bewertung der Luftdichtheit der Gebäudehülle – je dichter die Gebäudehülle, desto besser die Bewertung der Luftdichtheit.

Somit erfüllt heute das BNB noch nicht direkt, zumindest aber indirekt wesentliche Anforderungen an radonsicheres Bauen.

Die Thematik geogenes Radon wird derzeit im BNB-System für Neubauten im Bereich der Beurteilung des Standortes u.a. durch das Kriterium BNB_BN_ 6.1.2 Verhältnisse am Mikrostandort adressiert. Unter Einbeziehung der gebietspezifischen Radonkarte wird die Einstufung des Standortes informativ dem Bewertungsprozess zugeführt und stellt somit eine wichtige Basisinformation für die Gebäudeplanung dar.

Im Ergänzungsmodul BNB Nutzen und Betreiben wird die Thematik Radon während der Nutzungsphase im Kriterium BNB_BB 3.1.3 Tatsächliche Innenraumhygiene direkt betrachtet und bewertet. Für die Bauherren, die regelmäßige Qualitätskontrollen mittels BNB-Modul Nutzen und Betreiben während der Nutzungsphase vereinbaren, ist die Radonmessung somit nunmehr obligatorisch.

1. Flüchtige organische Stoffe (VOC) und Formaldehyd

Anforderungsniveau	
50	Raumluftkonzentration aller untersuchten Räume: TVOC $\leq 500 [\mu\text{g}/\text{m}^3]$ Formaldehyd $\leq 60 [\mu\text{g}/\text{m}^3]$
25	Raumluftkonzentration aller untersuchten Räume: TVOC $\leq 1000 [\mu\text{g}/\text{m}^3]$ Formaldehyd $\leq 60 [\mu\text{g}/\text{m}^3]$
10	Raumluftkonzentration aller untersuchten Räume: TVOC $\leq 3000 [\mu\text{g}/\text{m}^3]$ Formaldehyd $\leq 120 [\mu\text{g}/\text{m}^3]$

Abb. 4: Auszug BNB_BN - 3.1.3 – Teilkriterium Flüchtige organische Stoffe

2. Personenbezogene Lüftungsrate

Anforderungsniveau	
50	personenbezogene Lüftungsrate (qp) = 36,0 [m ³ /h]
35	personenbezogene Lüftungsrate (qp) = 25,2 [m ³ /h]
20	personenbezogene Lüftungsrate (qp) = 14,4 [m ³ /h]
0	personenbezogene Lüftungsrate (qp) < 14,4 [m ³ /h]

Abb. 5: Auszug BNB_BN 3.1.3 – Teilkriterium Personenbezogene Lüftungsrate

Zukünftige Entwicklungen

Aufgrund der nationalen und europäischen Entwicklungen im Hinblick auf Festlegungen zu Referenzwerten für geogenes Radon, ist die Integration von verbindlichen Nachweisen zur Radonkonzentrationen im Gebäude für das Bewertungssystem Nachhaltiges Bauen ebenfalls angedacht. Mit dem geplanten Update des BNB zum Ende des Jahres 2014, ist die Integration von ersten Qualitätsstufen für Radon im Steckbrief 3.1.3 Innenraumhygiene erklärtes Ziel. Die Ableitung der Qualitätsstufen erfolgt dabei in enger Abstimmung mit dem Bundesamt für Strahlenschutz.

Der Vorteil eines freiwilligen Bewertungssystems liegt u.a. darin, dass die zu erreichenden Mindestanforderungen sich einerseits an den nationalen Grenz-/ Referenzwerten orientieren und andererseits für die BNB-Zielwerte deutlich geringere Konzentrationen im Sinne eines nachhaltigen Gebäudes vereinbart werden können. In Abhängigkeit der europäischen Entwicklungen bzgl. der Einstufung/ Beurteilung der Eigenstrahlungen von Baustoffen, besteht ebenfalls die Möglichkeit diese Thematik mittelfristig in das BNB-System zu integrieren. Hier werden bei Bedarf die dafür erforderlichen Abstimmungen mit dem Bundesamt für Strahlenschutz sowie dem Deutschen Institut für Bautechnik geführt.

Fazit

Mit dem Bewertungssystem Nachhaltiges Bauen besteht unabhängig von Richtlinien, Verordnungen und Gesetzen die Möglichkeit, Gebäude zukünftig in Ihrer Ganzheitlichkeit besser bewerten zu können. Da es sich um ein offenes und ständig in der Weiterentwicklung befindliches System handelt, können Aspekte wie geogenes Radon sukzessiv stärker als bisher im System Berücksichtigung finden.

Regelungen des baulichen Radonschutzes für Neubau und Gebäudesanierung in Deutschland – aktueller Stand und erforderliche Entwicklungen unter Berücksichtigung der neuen Europäischen Richtlinien

Prof. Dr.-Ing. Walter-Reinhold Uhlig
HTW Dresden, Fakultät Bauingenieurwesen/Architektur
Kompetenzzentrum für radonsicheres Bauen und Sanieren (KORA e.V.)

Prof. Dr.-Ing. Thomas Hartmann
HTWK Leipzig, Fakultät Maschinenbau und Energietechnik
ITG Institut für Technische Gebäudeausrüstung Dresden GmbH

1. Einführung

1.1 Problemstellung

Der bauliche Radonschutz hat in Deutschland bisher noch nicht den Stellenwert erreicht, der sich aus den Erkenntnissen zur Gesundheitsgefährdung infolge einer erhöhten Radonkonzentration in Aufenthaltsräumen ergibt. Die Gründe hierfür sind in erster Linie in fehlenden verbindlichen Regelungen und einem geringen Kenntnisstand der Baufachleute zum baulichen Radonschutz zu finden. Im Rahmen dieses Beitrages sollen, aufbauend auf einer kurzen Darstellung der für Deutschland geltenden Voraussetzungen sowie der aktuellen Situation Schlussfolgerungen für erforderliche Maßnahmen zur Umsetzung der Europäischen Grundnorm in nationales Recht beschrieben werden.

1.2 Bodenradonkonzentration in Deutschland

In Deutschland konzentrieren sich die Gebiete mit hohen Bodenradonwerten auf einige Mittelgebirgs- und Alpenregionen (siehe Bild 1). Insbesondere sind die Bundesländer Sachsen und Bayern, im weiteren Thüringen, Baden-Württemberg, Rheinland-Pfalz, Saarland und Nordrhein-Westfalen betroffen.

Schätzungen [1] gehen davon aus, dass in Deutschland jährlich ca. 1.900 Menschen an durch erhöhte Radonkonzentration hervorgerufene Lungenkreberkrankungen sterben.

1.3 Regelungen im Bauwesen

Der im Bauwesen tätige Architekt, Bauingenieur und Fachplaner muss im Prozess der Planung sowie Bauausführung eine Vielzahl unterschiedlicher Regelungen berücksichtigen. Die folgende Zusammenstellung lässt die Komplexität der zu berücksichtigenden Gesetze, Normen und sonstigen Regelungen erahnen. Auf die Frage, wie bzw. wo sich in diese Regelungen der bauliche Radonschutz einordnen lässt, wird im anschließenden Abschnitt 2 eingegangen.

- Die gesetzliche Grundlage des Bauens in Deutschland stellt das Baugesetzbuch dar, in dem u.a. formuliert ist,

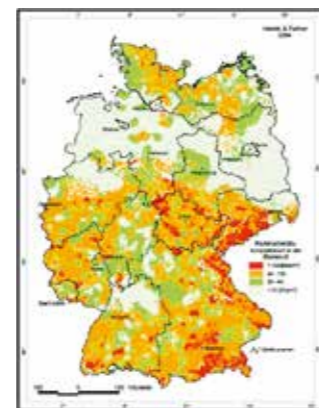

Bade-Westfalen

dass gesunde Wohn- und Arbeitsverhältnisse zu berücksichtigen sind.

- Die föderale Struktur Deutschlands spiegelt sich im Baurecht dahingehend wider, dass eine Vielzahl von grundsätzlichen Fragen in den Bauordnungen der Länder gesetzlich geregelt ist.

Sowohl das Baugesetzbuch als auch die Bauordnungen der Länder können keine konkreten Festlegungen zur planerischen Lösungen sowie deren Umsetzung enthalten. Derartige Regelungen sind z.B. in Verordnungen des Bundes, DIN-Normen, Normen des VDI sowie weiterer Verbände enthalten. Darüber hinaus existiert eine Reihe, zum Teil auf freiwilliger Basis begründeten, Regelungen.

- In Verordnungen sind besonders wichtige Aspekte des Bauwesens, wie z.B. Fragen des energetischen Bauens, geregelt.
- In DIN-Normen sowie diese ergänzenden Normen von Fachverbänden ist eine Vielzahl unterschiedlicher technischer Lösungen sowie Verfahren beschrieben. Mit Ausnahme bauaufsichtlich eingeführter DIN-Normen haben sie allerdings lediglich Empfehlungskarakter. Normen bilden zudem nicht automatisch die

allgemein anerkannten Regeln der Bautechnik (aaRdB) ab. Letztere müssen in der Wissenschaft als theoretisch richtig erkannt, in der Praxis umfassend bekannt sein und sich aufgrund langjähriger praktischer Erfahrung bewährt haben. Für die Feststellung einer mangelfreien Bauleistung haben die aaRdB überragende Bedeutung.

- Um eine hohe Bauqualität zu gewährleisten und ggf. Gefahrensituationen zu vermeiden, können für einzelne Bauprodukte bzw. Verfahren über freiwillige Vereinbarungen, z.B. in der Form eines RAL-Gütezeichens, ergänzende Kriterien geregelt werden.

Zunehmend werden Europäische Richtlinien als Grundlagen für nationale Regelungen beschlossen, wobei den Ländern in der Form der Umsetzung ein gewisser Spielraum zugestanden wird.

2. Aktueller Stand zu Regelungen des baulichen Radonschutzes in Deutschland

Wie in den meisten Ländern Europas existieren in Deutschland keine gesetzlichen Regelungen zum baulichen Radonschutz. Lediglich für einige wenige Gruppen von Arbeitsplätzen sind gesetzliche Grenzwerte zur Begrenzung der Radonkonzentration am Arbeitsplatz festgelegt worden.

Aus den grundsätzlichen Anforderungen des Baugesetzbuches zur Schaffung gesunder Arbeits- und Lebensbedingungen sowie weiterer gesetzlicher und normeller Regelungen lassen sich, wie Giesbert und Kleve in ihrem Beitrag auf dem 3. Sächsischen Radontag [2] schlüssig dargestellt haben, keine zwingenden Regelungen zum baulichen Radonschutz ableiten. Empfehlungswerte zur Begrenzung der Radonkonzentration in Aufenthaltsräumen sind im Radonhandbuch Deutschland [3] zusammengefasst.

Bauliche Regeln zur Umsetzung des Radonschutzes, Regelungen aus dem Bereich der Lüftungstechnik, Vorschriften zur Baustoffprüfung sowie Festlegungen zur Umsetzung des baulichen Radonschutzes sind für Deutschland nicht bekannt. Der wichtige Begriff der allgemein anerkannten Regeln der Bautechnik kann auf bauliche und anlagentechnische Lösungen des Radonschutzes (noch) nicht oder nur bedingt angewendet werden.

3. Kenntnisstand zum baulichen Radonschutz

Im Grunde genommen sind die baulichen und lüftungstechnischen Möglichkeiten zur Umsetzung des baulichen Radonschutzes für Neubau und Sanierung bekannt, auch

wenn diese – wie in Abschnitt 2 ausgeführt – noch nicht den Stand allgemein anerkannter Regeln erreicht haben.

Für Neubauten liegt der Schwerpunkt auf der Realisierung einer dichten Gebäudehülle im Bereich der erdangrenzenden Bauteile. Besondere Sorgfalt ist dabei auf die luftdichte Verwahrung von Rohrdurchführungen sowie den sorgfältigen Abschluss von Bauteilanschlüssen untereinander zu legen, um konvektive Luftströmungen zu verhindern. Lüftungstechnische Maßnahmen, auf die im Folgenden im Zusammenhang mit Sanierungsaufgaben eingegangen wird, können die baulichen Maßnahmen im Neubau ergänzen.

Im Falle der Sanierung bestehender Gebäude ist es oft nicht möglich, die Gebäudehülle so abzudichten, dass der konvektive Luftstrom zwischen Erdreich und Gebäudeinnerem verhindert wird. Für diese Fälle können die folgenden Maßnahmen zur Reduzierung der Radonkonzentration in den Räumen angewendet werden:

- Erhöhung der Luftwechselrate in den genutzten Räumen: Diese Maßnahme wird vorrangig als Sofortmaßnahme angewendet, wenn sehr hohe Radonkonzentrationen in der Raumluft festgestellt worden sind. Da ein erhöhter Luftwechsel gleichzeitig zu höheren Energieverlusten führt, ist diese Maßnahme für beheizte Räume allenfalls als temporäre Maßnahme geeignet.

- Umkehr des konvektiven Luftstroms zwischen Gebäudeinnerem und dem Erdreich: In der Regel stellt sich ein Unterdruck im unteren Bereich des Gebäudes gegenüber dem Luftdruck im angrenzenden Erdreich ein. Dieser Unterdruck kann durch eine höhere Raumlufttemperatur gegenüber der Temperatur im Erdreich (Winterzustand), durch den sogenannten Kamineffekt oder aber durch Windanströmung an das Gebäude entstehen. Möglichkeiten, den Unterdruck im Gebäude abzubauen, sind zum Beispiel die Abschottung der Kellerräume von den darüber liegenden Gebäudebereichen (Reduzierung des Kamineffekts) sowie die Reduzierung des Luftdruckes im Erdreich direkt unterhalb der Gebäudesohle. Für letztere Maßnahme werden beispielsweise sogenannte Radonbrunnen unterhalb oder direkt neben dem Gebäude errichtet bzw. wird unter der Bodenplatte eine Flächendränage mit direkter Anbindung an die Außenluft eingebaut. Eine weitere Möglichkeit ist die Schaffung bzw. lüftungstechnische Aktivierung von Hohlräumen in bzw. kurz unter der Bodenplatte. Alle hier genannten Maßnahmen werden so konzipiert, dass Luft aus dem Boden abgesaugt und somit ein Unterdruck im gebäudeangrenzenden Erdreich induziert wird.

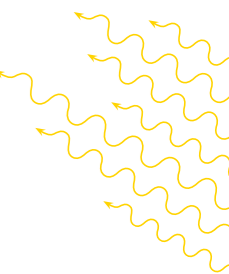

■ In letzter Zeit werden – vor allem im Neubau, aber auch bei energetischen Gebäudesanierungen – verstärkt Lüftungsanlagen errichtet, die die Regelung der Luftwechselrate ermöglichen. Beispielsweise durch Integration eines Wärmeübertragers können mit dieser Lösung die Energieverluste, die sich durch den hygienisch oder bautechnisch motivierten erhöhten Luftwechsel ergeben, deutlich reduziert werden. Werden diese Systeme mit einem geringen Überdruck im Gebäude betrieben (das ist bei Zu-/Abluftanlagen sowie bei reinen Zuluftanlagen möglich), führen diese Systeme im Zusammenhang mit den erhöhten Luftwechselraten zwingend zu einer – zumeist deutlichen – Reduzierung der Radonkonzentration in der Raumluft.

Eine fachgerechte Umsetzung der hier kurz skizzierten baulichen und Lüftungstechnischen Maßnahmen kann nur dann erfolgreich realisiert werden, wenn die Bauschaffenden, aber auch öffentliche und private Bauherren über genügend Wissen zum baulichen und anlagentechnischen Radonschutz verfügen. Sowohl im Kreise der Architektenschaft als auch der Bauingenieure und weiterer Fachplaner sind die Lösungen des baulichen Radonschutzes aber bisher noch zu wenig bekannt. Zudem fehlt sowohl bei den Bauherren als auch den Bauschaffenden häufig die Sensibilität hinsichtlich der Erkennung eines Radonproblems. Dies ist in erster Linie auf fehlende verbindliche Regelungen (s. Punkt 2) zurück zu führen, aber auch auf die Tatsache, dass der bauliche Radonschutz bisher in der Ausbildung an Universitäten und Hochschulen nur eine geringe Rolle spielt und Weiterbildungsmaßnahmen selten angeboten bzw. nur von wenigen angenommen werden. Zudem fällt auf, dass Veröffentlichungen zum baulichen Radonschutz nahezu ausschließlich aus den Bereichen des Strahlenschutzes kommen, u.a. durch das BfS, einige Landesämter bzw. Länderministerien sowie einige renommierte private Büros, in erster Linie wiederum aus dem Bereich des Strahlenschutzes, der Strahlenschutzmessung sowie der Geologie. Auffällig und durchaus als problematisch einzuschätzen ist die Tatsache, dass demgegenüber aus dem Bauwesen so gut wie keine Veröffentlichungen und sonstigen Aktivitäten bekannt sind. Das betrifft sowohl die Berufsverbände und Kammern, Verwaltungseinheiten, die Bauforschung sowie Planer und die Baustoffindustrie. Diese Beobachtung ist deshalb als problematisch einzuschätzen, da dadurch die spezifischen Fragen und Antworten, die sich im Zusammenhang mit der Planung und Bauausführung ergeben (s. u.a. Hinweise zu rechtlichen Regelungen des Bauwesens in Punkt 1.3.) zu wenig Berücksichtigung finden.

4. Aktivitäten in Deutschland

4.1 Ein Überblick über die zu lösenden Fragen

Die Ausführungen der Abschnitte 2 und 3 zeigen, dass im Vorfeld der Umsetzung der Europäischen Grundnorm in nationales deutsches Recht eine Reihe von Fragen geklärt und umgesetzt werden müssen. Das betrifft vor allen Dingen die folgenden Schwerpunkte:

- Schaffung klarer Prüfregele für Baustoffe und Baukonstruktionen;
- Formulierung von Regeln zur Messung der Radonkonzentration in der Raumluft vor sowie nach einer Baumaßnahme einschließlich der Einführung von Referenzwerten;
- Beschreibung geeigneter baulicher und anlagentechnischer Radonschutzmaßnahmen einschließlich der Formulierung von Qualitätsstandards in der Bauausführung;
- Umfassende Schulung und Weiterbildung der Bauausführenden sowie Sensibilisierung der öffentlichen und privaten Bauherren für Fragen des Radonschutzes.

4.2 Institutionelle Aktivitäten

Traditionell werden Fragen des Radonschutzes im Bundesamt für Strahlenschutz (BfS) behandelt. Dabei muss eingeschätzt werden, dass bisher die in Punkt 4.1 aufgeworfenen Fragen deutlich zu kurz gekommen sind. Die aktuelle Situation in Deutschland ist für das Bauwesen insofern unbefriedigend, dass in nahezu alle Richtungen Rechtssicherheit fehlt. Die Lösung kann nur darin gefunden werden, dass eine intensive Zusammenarbeit mit der Baubranche mit dem Ziel gefunden wird, dieser klare Regelungen an die Hand zu geben. Es ist dabei unerheblich, ob diese in Form von Gesetzen, DIN- oder anderen Normen oder aber durch die Formulierung von Qualitätsstandards, z.B. über ein RAL-Gütesiegel erarbeitet und eingeführt werden. Entsprechende Regelungen sind dabei für die folgenden Themengruppen erforderlich:

- Definition von Zielwerten: Hier dürften die Referenzwerte der EU-Grundnorm entsprechende Klarheit bringen, auch wenn für das Bauwesen die Anwendung von Referenzwerten bisher nicht üblich ist und deshalb zu Unsicherheiten bei der rechtlichen Bewertung führen wird. Da es aber weitestgehend Konsens ist, dass die Definition von Grenzwerten aus fachlicher Sicht problematisch ist, sollte das Bauwesen mit dieser Situation umzugehen lernen.

■ Festlegung von Regularien zur Radonmessung und Qualitätskontrolle: Es müssen eindeutige Regelungen erarbeitet und eingeführt werden, wann und in welcher Form sowie mit welchen Verfahren die Radonkonzentration gemessen wird. Ebenso sind einheitliche und reproduzierbare Regelungen zur Messung der Radonexhalation aus Baustoffen festzulegen. Bei allen Festlegungen muss dabei der Schwerpunkt auf der Reproduzierbarkeit von Messungen und damit der Möglichkeit einer unabhängigen Kontrolle sowie der Definition klarer Qualitätsstandards liegen.

■ Beschreibung von Bau- und Technikstandards für den baulichen Radonschutz im Neubau und bei der Sanierung: Wie bereits in Abschnitt 3 festgestellt, sind bauliche und Lüftungstechnische Lösungen für Neubau und Sanierung weitestgehend bekannt. Fragt man allerdings Bauingenieure und Architekten nach ihrem diesbezüglichen Wissen, muss festgestellt werden, dass die Möglichkeiten bisher viel zu wenig bis zu den baupraktisch Tätigen durchgedrungen sind. Eine ähnliche Situation kann auch für die Lüftungsbranche konstatiert werden. Sowohl für den Bauschaffenden als auch den Bauherren dürfte die Tatsache, dass vor allen Dingen im Sanierungsbereich die übliche Wirkungskette:

Realisierung einer baulichen und anlagentechnischen Lösung mit einer definierten Ausführungsqualität führt planbar zu einem bestimmten Ergebnis

für den Radonschutz nicht zwingend anwendbar ist. Dies wird mit Sicherheit zu rechtlichen Fragen und ggf. Irritationen führen, die dringend einer Klärung bedürfen.

4.3 Aus- und Weiterbildung

Die Vermittlung ausreichender Kenntnisse zum baulichen Radonschutz ist für alle im Bauwesen Tätigen eine zentrale Aufgabe der nächsten Jahre. Hier sind neben den Universitäten und Hochschulen vor allen Dingen Weiterbildungsanbieter, die Kammern, aber auch staatliche Stellen angesprochen. Die bisherigen Aktivitäten in Deutschland konzentrieren sich im Wesentlichen auf Initiativen aus Bayern und Sachsen mit der

- Ausbildung zur Radonfachperson (nach Schweizer Vorbild), der
- Durchführung des Sächsischen Radontages durch das Kompetenzzentrum für radonsicheres Bauen und Sanieren (KORA e.V.) gemeinsam mit dem Sächsischen Ministerium für Umwelt und Landwirtschaft (SMUL),

der gemeinsam mit seiner Vorgängertagung in diesem Jahr bereits zum 9. Mal stattfand sowie

■ einigen wenigen Initiativen von Weiterbildungsträgern und Fachpersonen in ganz Deutschland.

Allerdings kann erfreulicher Weise beobachtet werden, dass es in den letzten Jahren ein steigendes Interesse an Weiterbildungsmaßnahmen im Bereich des baulichen Radonschutzes gibt.

Die Integration des baulichen Radonschutzes in das Architektur- und Bauingenieurstudium ist bisher lediglich an der HTW Dresden gelungen, wo seit 2009 eine eigenständige Lehrveranstaltung angeboten wird. Auch hier gibt es inzwischen erste Aktivitäten, diese Initiative auf weitere Universitäten und Fachhochschulen zu übertragen.

5. Zusammenfassung

Das Wissen zum baulichen Radonschutz ist vorhanden und vielfältig erprobt. Trotzdem kann es aktuell nicht als „allgemein anerkannte Regeln der (Bau-)technik“ eingeordnet werden, da nicht davon auszugehen ist, dass die Fragen und Lösungen des baulichen Radonschutzes allgemein bekannt sind und es bisher keine klaren Regularien für deren Umsetzung gibt. Der Beschluss der EU-Grundnorm und dessen Überführung in nationales Recht erfordert deshalb in den nächsten Jahren vielfältige Aktivitäten. Dabei sind vor allen Dingen die im Bauwesen tätigen Hochschulen und Forschungseinrichtungen, Weiterbildungsträger und öffentlichen Einrichtungen, aber auch die Gesetzgebung in Bund und Ländern gefragt, das Wissen zum Radonschutz in die Baupraxis zu überführen und gleichzeitig ein Regelwerk zum baulichen Radonschutz zu schaffen.

Literaturverzeichnis:

- [1] Gesundheitliche Auswirkungen von Radon in Wohnungen (www.bfs.de/de/wirkungen/wirkungen_radioaktive_stoffe/radon_ges.html)
- [2] Gisbert, Ludger und Guido Kleve: Öffentlich-rechtliche Verantwortung und zivilrechtliche Haftung für Radonbelastung; Tagungsband 3. Sächsischer Radontag, Dresden 2009
- [3] Bundesministerium für Umwelt, Naturschutz und Reaktorsicherheit: Radon-Handbuch Deutschland, Bonn 2001

The future Spanish Building Code on the radon protection area and the current regulatory situation in Spain

Linares-Alemparte, Pilar – Architect
Eduardo Torroja Institute for Construction Sciences. CSIC

García-Ortega, Sonia – Industrial Organization Engineer
Eduardo Torroja Institute for Construction Sciences. CSIC

Abstract

This paper aims to summarize the current situation in Spain in terms of regulations and procedures related to protective measures targeting radon gas by providing a general overview on the normative and regulatory landscape and describing the guidelines of the draft legislation for protection against radon gas in Spain's national building regulations.

The Consejo de Seguridad Nuclear (Council for Nuclear Safety, or CSN), has been addressing radon issues since 1989, and recently has delivered a map which identifies the specific national geographies that are demonstrated to be prone to radon risk, specific regulations for workplaces and a documented methodology to deal with radon protection.

The Ministerio de Vivienda (Ministry of Housing), approved in 2006 a performance-based national building regulation which specifies the fundamental requirements or performance that buildings must provide for compliance. This regulation, known as Código Técnico de la Edificación (Building Code, CTE), addresses hygiene and health, including indoor air quality, and specifies the conditions indoor air must have in relation to general pollutants. It does not, however, include any explicit guidelines relating to the impact of radon on air quality.

The Ministerio de Fomento (Ministry of Public Works), in collaboration with the CSN and relying on technical support from the Instituto de Ciencias de la Construcción Eduardo Torroja (Eduardo Torroja Institute for Construction Sciences, IETcc), from the Consejo Superior de Investi-

gaciones Científicas, (High Council for Scientific Research, CSIC), is currently developing a draft extension to the CTE, revisiting the requirement for indoor air quality to take into consideration protection against radon in residential buildings.

1. Current state of radon risk awareness and protection in Spain

Protecting people against radon in buildings is a burgeoning issue. To date, the main issues addressed by building performance analyses were more "traditional", dealing with energy saving, noise insulation, damp protection, fire safety, and so on. Because of improved awareness provided by European directives and international and national entities (such as WHO and the Spanish Ministry of Health and Social Policy), national authorities have more recently begun to develop guides, recommendations and instructions on the matter.

1.1. Nuclear Safety Council (CSN), maps, instructions and guidance documents

The Nuclear Safety Council (CSN) is the Spanish authority in charge of nuclear safety and radiology protection: natural and artificial.

Although there is no specific state policy on radon protection the CSN, in collaboration with other entities and universities, has dedicated the last 25 years to the better understanding of existing radon levels with the aim of improving the use of public resources in the design of protection strategies.

As a partial transposition of 96/29 EURATOM Directive [1], CSN approved the Royal Decree 783/2001 "Regulation on sanitary protection against ionizing radiation" [2]. Another part of the Directive had been transposed in the Royal

Decree 1836/1999 "Regulation on nuclear and radioactive facilities" [3]. The Royal Decree 783/2001 describes which commercial & industrial activities must control their radon levels, but without specifying which control measures must be taken.

To further develop this work, CSN published (2012), the compulsory "Instruction IS-33 on radiological criteria for the protection against the exposition to natural radiation" [4] which establishes the protective measures (technical and administrative), required to be taken in workplaces, based on an annual mean radon concentration during working hours:

- $< 600 \text{ Bq/m}^3$, no control is necessary
- $\geq 600 \text{ \& } \leq 1000 \text{ Bq/m}^3$, low control is necessary
- $> 1000 \text{ Bq/m}^3$, high control is necessary
- In schools and workplaces where people spend long periods of time, including prisons and hospitals; the reference level is lower: 300 Bq/m^3 .

Furthermore, CSN has developed a number of methodology-based guidance documents, among which we highlight "GS-11.01 Guideline on laboratories competences and services of radon measurement in air" [5], "GS-11.02 Control of natural radiation exposition" [6] and "GS-11.04 Method for the assessment of radon exposition in work places" [7].

In addition to the above mentioned instructions and guidelines, CSN has developed a map of radon-prone areas in Spain which shows the potential radon exposition rate of peninsular land at a 1:1.000.000 scale [8]. The map has been produced combining data from indoor radon measurements with natural α -radiation (microrentgens per hour at 1 m above ground, MARNA map) [9] [10], and geological maps. This approach relaxes the need for high density sampling by using commonly available information. It can

be applied for an initial definition of radon-prone areas. The map classifies an area as radon-prone when the 90th percentile of predicted indoor radon concentration in its building stock is greater than the reference level: 300 Bq/m^3 .

As can be seen from the map, the radon-prone area extends in areas of the North – West and the centre of Spain. Taking into account the Spanish Population and Housing Census from the Instituto Nacional de Estadística (National Institute of Statistics) [11], map of radon-prone areas [8], MARNA map [9] and other measurement campaigns [12], the number of adversely affected households is estimated at around 1.6 million households from a total of 25.2 million.

The indoor radon database used to do the radon-prone areas map currently has over 11000 records. The sampling density is spatially heterogeneous, tending to be higher in areas with high radon level and more populated. This database has got some limitations: it neither details precise location, nor provides information on building construction details. Furthermore, the number of measurements is reduced compared to the building stock.

A new sampling campaign was launched in 2013 with a predicted three-year lifespan, in order to provide base data to improve the current radon-prone map covering the whole territory of Spain, including the Balearic and the Canary islands.

1.2. Ministry of Public Works and Building Code

In 2006 the Ministry of Housing approved the current national Building Code (CTE) [13] - a performance-based regulation which specifies the fundamental requirements or performance which buildings must fulfil.

The CTE comprises: Energy saving, Noise insulation, Structural safety, Use safety and Accessibility, Safety in case of an event of fire, and Hygiene and health. This final requirement deals with matters such as protection against damp & condensation, waste management, water supply & drainage, and indoor air quality. The requirement for indoor air quality specifies the conditions required in relation to general pollutants, but it does not include an explicit requirement on radon.

Therefore, and because of the rising awareness of society and various recommendations of international and national entities, the Spanish Ministry of Public Works, with the collaboration of CSN and the technical support of the Eduardo Torroja Institute for Construction Sciences from the CSIC, is developing a draft on radon protection regulation to be included in a forthcoming revision to the CTE.

2. Radon protection regulations within the Building Code

The main goal of this regulation is to protect the population from the negative effects on health produced by the accumulation of indoor radon gas.

The scope of this regulation would specifically be housing, due to the long exposure times and because workplaces are already regulated in Instruction IS-33.

It is well known that indoor radon concentration depends directly, among other factors, on building characteristics. Therefore this regulation intends to enforce the implementation of appropriate building solutions, depending on the actual indoor radon concentration in existing buildings, or on the expected concentration in new buildings.

A concentration limit will be set up that will be used to calibrate the remedial or protective measures to take.

The proposed methodology is different for existing and new buildings. For existing buildings the process starts with the measurement of the indoor radon concentration prior to any works and then, according to this level, a set of remedial solutions will be advised until the measured concentration is below the limit. For new buildings the process starts with the estimation of the radon high concentration risk and then, according to the risk level, a set of protective solutions will be recommended.

2.1. Estimation of the radon high concentration risk in new buildings

Between the two most commonly used methods in international radon regulations for establishing the high concentration indoor radon risk, the use of on-site measurements of relevant soil characteristics is proposed instead of the use of the available radon-prone areas map.

The map of radon-prone areas we mention above can be used for guiding territorial policies on radon protection and for getting to know the degree of the problem in each geographical area - though recall that data is sparse in some areas.

Therefore the on-site measurements alternative has been chosen as a better way to determine the risk. Following the Czech Republic method described in SN 73 0601 [14], the risk is established as a function of the soil radon concentration and the soil air permeability.

2.2 Remedial and protective solutions

Having estimated the risk or measured the indoor radon concentration, there will be a graduated scale of applicable solutions to address each grade of pollution. The solutions included in the draft are already well-documented in the literature [14] [15] [16], and reportedly effective. For new buildings, the currently proposed graduated scale includes for medium risk the use of radon-proofed barriers and for high risk the use of, in addition to the barrier, other systems based on sub-floor depressurization (sumps) or ventilation.

Acknowledgments

Marta García-Talavera. CSN.

References

- [1] Council Directive 96/29 EURATOM Laying down basic standards for the health protection of the general public and workers against the dangers of ionizing radiation. OJ L159.
- [2] Real Decreto 783/2001, de 6 de Julio, Reglamento de protección sanitaria contra las radiaciones ionizantes, BOE 178, de 26 de Julio de 2001.
- [3] Real Decreto 1836/1999, de 3 de diciembre, Reglamento sobre instalaciones nucleares y radiactivas, BOE 313, de 31 de diciembre de 1999.
- [4] CSN Instrucción IS-33 sobre criterios radiológicos para la protección frente a la exposición a la radiación natural. BOE nº 22 de 26 de enero de 2012.
- [5] CSN 2011 Guía de Seguridad 11.01 Directrices sobre la competencia de los laboratorios y servicios de mediación de radón en el aire (Madrid:CSN).
- [6] CSN 2011 Guía de Seguridad 11.02 Control de la exposición a fuentes naturales de radiación (Madrid:CSN).
- [7] CSN 2011 Guía de Seguridad 11.04 Metodología para la evaluación de la exposición al radón en los lugares de trabajo (Madrid:CSN).
- [8] García-Talavera, Marta et al. Mapping radon-prone areas using γ -radiation dose rate and geological information. *Journal of radiological protection*, 33 (3) (2013): 605-20.
- [9] Proyecto MARNA. Mapa de radiación gamma natural. Consejo de Seguridad Nuclear. Colección Informes Técnicos 5.2000. ISBN: 84-95341-12-3.
- [10] Quindós Poncela, L.S. Natural gamma radiation map (MARNA) and indoor radon levels in Spain. *Environment International*, 29 (2004): 1091-1096.
- [11] Censos de Población y viviendas 2011. Instituto Nacional de Estadística. http://www.ine.es/en/censos2011_datos/cen11_datos_res_pob_en.htm

- [12] CSN Concentraciones de radón en viviendas españolas. Otros estudios de radiación natural. Colección Informes Técnicos 13.2004. Referencia INT-04.09.
- [13] Real Decreto 314/2006, de 17 de marzo, Código Técnico de la Edificación. Ministerio de Vivienda, BOE 314, de 28 de marzo de 2006. <http://www.codigotecnico.org/ingles/introduction/>
- [14] Ochrana staveb proti radonu z podloží. ESKÁ TECHNICKÁ NORMA. SN 73 0601
- [15] Chris Scivyer. Radon. Guidance on protective measures for new buildings. BRE Press. 2007. Watford. UK
- [16] Bernard Collignan. Guide technique: Le radon dans les bâtiments. CSTB. 2008

Radon in Ireland and the New National Radon Strategy

Eamonn Smyth – (DECLG, Ireland)

Background

The National Radon Survey was carried out by the Radiological Protection Institute of Ireland (RPII) during the 1990s. This survey, which was based on measurements in over 11,000 homes, predicted that 7% of the national housing stock in existence at the time had radon concentrations above the National Reference Level of 200 Becquerels per cubic metre (Bq/m³) for radon in homes¹. Based on the results of the survey, a map of Radon in Irish Dwellings was published (Figure 1)², identifying High Radon Areas³. Approximately one third of the country, mainly in the west and south-east, is classified as a High Radon Area. Due primarily to geological factors the radon problem in Ireland is greater than for many of our European neighbours. The average indoor radon concentration in Ireland is 89 Bq/m³, which is the eighth highest among 29 OECD countries surveyed by the World Health Organisation⁴. Some of the highest indoor radon concentrations, found anywhere in Europe, are in Ireland.

It is the greatest source of exposure to ionising radiation for the general public and the second greatest cause of lung cancer in Ireland. It is estimated that exposure to radon accounts for approximately 13% of all lung cancers in Ireland, which equates to some 250 lung cancers each year.

The Reference Level for the long-term exposure to radon in homes is 200 Bq/m³ measured in accordance with the RPII's measurement protocol. This Reference Level, which was set by Government in 1990, is in line with the recommendations of the World Health Organisation⁵.

Building Regulations:

The Building regulations introduced requirements in 1997 which stated "Reasonable precautions shall be taken to avoid danger to health and safety caused by substances (including contaminants) found on or in the ground to be covered by a building" and defined "contaminant" as "any substance which is or could become flammable, explosive, corrosive, toxic or radioactive and any deposits of faecal or animal matter,"

The Technical Guidance Document to the regulations specified two requirements for dwellings and other long-stay residential buildings depending on the designation of the location:

1. High Radon Areas - a fully sealed membrane of low permeability over the entire footprint of the building and a potential means of extracting Radon from the substructure such as a standby Radon sump or sumps with connecting pipe work or other appropriate certified systems

2. Areas other than High Radon Areas - the provision of a standby Radon sump or sumps with connecting pipe work or other appropriate certified systems.

The pipe work from standby Radon sumps, should terminate and be capped either above ground level externally, or in the attic space. Pipe terminals should be clearly marked to indicate the function of the pipe work system to facilitate later activation should this prove necessary and also prevent misuse.

Schools

The statutory Reference Level for radon in workplaces of 400 Bq/m³ also applies to schools. However, in order to provide the same level of protection as in the home, the RPII recommends a Reference Level of 200 Bq/m³ in all schools. This advice covers pre-schools as well as primary and post-primary schools.

Between September 1998 and June 2004 the RPII, on behalf of the Dept. of Education and science (DES), carried out a national program of radon measurements in primary and post primary schools in Ireland. All rooms with a radon concentration over the reference level of 200 Bq/m³ were to be identifying and remediated.

38,531 ground floor classrooms and offices in 3,826 schools were measured and 3,028 rooms were found to be over the reference level. Of these 800 were over 400 Bq/m³ and 126 had a measurement over 1000 Bq/m³. Large variations were observed between adjacent rooms in some cases.

Priority was given to schools with radon measurements over 400 Bq/m³ and a consultant was employed by DES

to design active sump remediation systems for 93 schools between 2000-2002. After a study of ventilation rates in schools found that existing rates were poor, it was decided to remediate schools with radon measurements between 200-400 Bq/m³ by increasing the background ventilation giving the added benefit of good indoor air quality.

Post remediation tests showed excellent results where active sumps were used with 95% of the remediated rooms below the 200 Bq/m³ reference level and only 1% above the 400 workplace reference level. Reductions were also observed in adjoining rooms not remediated. A 55% reduction in levels was observed in rooms remediated by background ventilation which was sufficient for the range of measurements treated ie 200- 400 Bq/m³.

National Radon Control Strategy

Radon is the greatest source of radiation exposure to the public. Experience in Ireland and abroad has shown that an effective response to the radon problem involves a wide range of interventions including:

- effective prevention in new buildings,
- identification of existing homes and workplaces with high radon levels,
- remediation of existing buildings,
- awareness raising,
- training, supports and enforcement.

It is clear that such a response requires action from a wide range of public bodies and other stakeholders and can be best achieved within the framework of a coordinated Government-led strategy.

The aim of the National Radon Control Strategy is to minimise the exposure to radon gas for people in Ireland and to reduce to the greatest extent practicable the incidence of radon related lung cancers. Thus, the Strategy

recommends a broad range of measures, 48 in total, based around six thematic areas as follows:

- Radon prevention in new buildings;
- Use of property transactions (sales and rental) to drive action on radon;
- Raising radon awareness and encouraging individual action on radon;
- Advice and guidance for individual householders and employers with high radon results;
- Promoting confidence in radon services; and
- Addressing radon in workplaces and public buildings.

From the construction industry standpoint the main recommendations are:

1 Short targeted training courses should be provided for site staff on the correct installation of radon preventive measures and on maintaining the integrity of those measures once installed. The aim of this would be to:

- Explain the dangers of Radon
 - The purpose of the standby sump
 - The necessity of maintaining the barrier intact
- This course to be done through industry groups.

2 Basic information on radon should be included on undergraduate courses related to the construction industry.

- Currently the 3rd level training appears to deal with barriers as part of the Damp Proof Membranes (DPM) for buildings without any emphasises on the dangers or reasoning behind the requirements.
- National reference levels etc

¹ The Reference Level is not a rigid boundary between safety and danger but represents a radon concentration above which action to reduce radon levels is likely to be needed.

² An interactive radon map is published on the RPII's website: www.rpii.ie.

³ A High Radon Area is one where it is predicted that more than 10% of homes will have radon concentrations above 200 Bq/m³

⁴ World Health Organisation, 2009, Handbook on Indoor Radon – A Public Health Perspective. This handbook is a key product of the WHO International radon project which was part funded by the Irish Government.

⁵ World Health Organisation, 2009, Handbook on indoor radon – A public health perspective. The is available at: http://www.who.int/ionizing_radiation/env/radon/en/index1.html. The handbook is a key product of the WHO International radon project which was part funded by the Irish Government.

3 In cooperation with the relevant professional bodies education on radon should be integrated into the existing system of continuous professional development (CPD) for building professionals.

- The aim here would be to increase the expertise of the construction professional both for prevention and resultant remediation
- Explain other remediation methods
- Design methods to reduce the risk of damage to barriers

4 A web based knowledge resource on radon should be developed for the building industry. The aim is to have available:

- Information on the dangers,
- methods of prevention and remediation,
- FAQ's (Frequently asked questions) for the homeowner and the professional.

5 The relevant Technical Guidance should be amended to require that a passive sump be installed in all new dwellings

- There is increased evidence that a passive sump reduces radon by 50% or more
- Little added cost to the current sump requirements
- Aids the proper positioning and installation.

6 The relevant Technical Guidance should be amended to include provisions, which would allow radon preventive measures to be more easily identified on site.

7 The current requirement that barriers are required in High Radon Areas should stand. Research should be carried out to assess the combined effectiveness of passive sumps and barriers compared to the effectiveness of barriers alone.

8 Research on better barrier systems and the appropriate placing of barriers to improve barrier success rate and decrease post-installation damage should be undertaken.

9 Other Research themes for better prevention and remediation incl.:

- Research on passive sumps and barrier vs passive sump only
- Improved barrier installation

- More evidence on effectiveness of prevention and remediation
- Insulation retrofit and radon levels

Awareness programs are also being developed to increase the testing and remediation of existing buildings. This combined with the development of a recognised list of competent remediation companies to give confidence to the home owner should lead to greater numbers of dwellings being rectified.

It is hoped that all the actions combined will have a significant impact on current Radon levels and reduce the risk to people in Ireland.

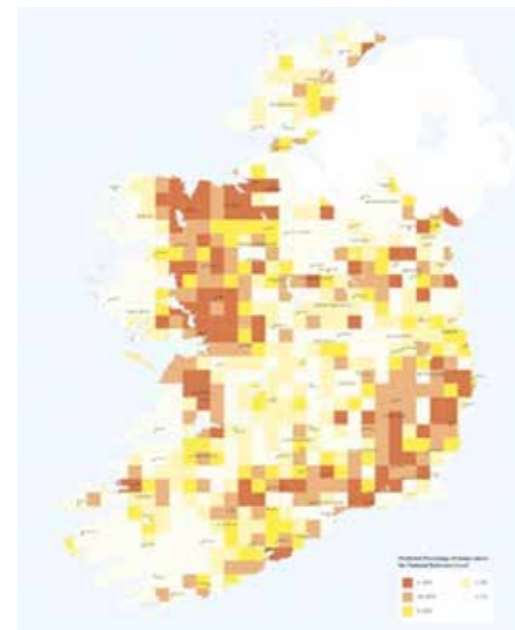

Figure 1

Radon mitigation in dwellings using radon extractors

Mattias Park

Corroventa Avfuktning AB, Sweden

Corroventa assets

Corroventa business unit: Living Environment: Radon mitigation

Equipment developed for the purpose, rental of instruments for radon measuring
Many years of actual experience in measurement and investigation, est. 19 000, and radon mitigation projects est. 3 000.

National Targets Radon- Target- and limit values in Sweden.

- Homes: 200 Bq/m³, Schools: 200 Bq/m³
- Workplaces: 200 Bq/m³ (Acc. To AFS 2011:18. Valid from 1th of July 2012)
- National radon target (Parliament's objective indoor Climate proposition)
- Radon level in all schools and preschools shall be below 200 Bq/m³ at year 2010.
- Radon level in all homes shall be under 200 Bq/m³ at year 2020.
- Also: All buildings where people frequently or for longer period reside at latest the year of 2015 has a documented efficient ventilation.

Radon work in Sweden, Allocation of responsibility, many different parties involved in different areas due to indoor radon.

Situation in Sweden

The situation for dwellings in Sweden, average value in Sweden, radon concentration and number of dwellings over a value of 200 Bq/m³ estimated to 500 000 pcs or 12% and over a value of 400 Bq/m³ estimated to about 150 000 pcs or 3,7%.

Sources of indoor radon concentrations

1. Soil gas: In Sweden we have bedrock that in principle for 90% of our suitable area for development has so much radon gas in the ground that, under certain conditions can cause measurable radon gas values in our buildings.

2. Building materials: Building materials that produce radon gas itself to such an extent that it gives a not negligible contribution of radon gas to our homes and buildings. The most high-producing material is commonly known as "blue autoclaved lightweight concrete" primarily used in

Sweden during 1920-1975. But the fact is that basically all domestic stone materials contribute to measurable level of radon in our homes.

3. Water: We also have radon transported through our tap water into the housing and which produces radon gas presence.

What is special for Sweden is the autoclaved lightweight concrete which we always has to consider when doing radon investigations.

Production of autoclaved lightweight concrete i Sweden Produced 63000000 (m³) during the time period of 1929-1975 with a gammaradiation of 0,25-1,00 µSv/h.

Estimated presence in existing dwellings in Sweden. 30 000 houses of apartment buildings and 125 000 family houses.

Season for measurement

The time for measurement of radon level should in Sweden be made during the period of heating season 1/10 – 30/4. Assumed period when average daily temperature is below +10°C. Most important is that the difference between indoor and outdoor temperature is sufficient for natural ventilation to operate.

Placing the radon meter in apartment buildings

- In apartment buildings measuring should be done in all apartments in the bottom floor.
- When it's not above a cellar floor.
- In floors above at least one apartment per floor, and cover at least 20% of the apartments i higher floors.
- All apartments in connection with elevator- or ventilation shafts should be measured.

Choose methods of radon mitigation – Some basic themes that we try to follow when we work with radon mitigation / planning.

If it's building materials that produce radon:

- Dilution of the production "as far as this is possible".
- Venting of the surface layer.
- Removal of material producing radon gas

If it's soil gas:

- Changing the pressure conditions in the housing body.
- Dilution of the incoming air leakage.
- Sealing of structures.

If it's from water:

- Venting the water before leading into the house.
- The choice of technologies and systems should always be made so that existing installations can continue to serve the house in a valuable manner.

Always to consider when selecting systems and technology

- The technique should also have a long-term functional and adjusted to the unique house, where changes that could negatively affect the building structures are avoided.
- It should under no circumstances occur comfort problems due to the selected technology / systems.
- Energy use should be considered when choosing an systems and technology. "Use the amount of energy is reasonably proportionate to the completed case. "
- Systems and technology should be easy to service and repair so that maintenance and repairs can be made quickly and easily.

Typical radon mitigation family house, example

This is a typical object where an installation of a radon extractor fan in the basement most often is the cheapest and most efficient solution. What causes the contaminated air to enter the house is the lower pressure in the house caused by the ventilation, mechanical or caused by the chimney/stack effect. Therefore the key is to modify the pressure ratio between the living environment and the pressure under the house. A common mistake is to increase the ventilation in the house. That results in an even lower pressure inside the house which causes even more contaminated air to be sucked into the house from the soil and thus increasing the radon level instead of decreasing it.

For the installation with a radon extractor fan RS400 was chosen since the soil under the house is relatively porous and air flow rather than pressure is needed to build up the required under pressure. The tubing system in the house could also be built quite compact and thus the pressure performance of the RS100 is not needed.

The process lowers the pressure under the house to a level below the pressure inside the house. That eliminates radon contaminated air from entering the living environment completely or decreases the amount significantly. Where possible, leakage between the soil and the house is also sealed, i.e. at lead through for drainage pipes etc.

Longtime measurement in apartment building

The importance to present the measuring data to the customer in a understandable and easy way.

Mitigation of radon with by new ventilation system, S – FTX, Present result of measuring before and after the installation. High levels caused of building material. Which can be very difficult to measure. Therefore measuring of gamma radiation has to be done. So you get proper values for the contribution of the Becquerel concentration and then can calculate the air circulation needed to achieve desired radon levels.

Some things to remember about Ventilation FTX and presentation of the result after a mitigation with exhaust ventilation system (F) and supply air vents.

Actionplan – how to plan the steps in a radon mitigation project.

To deal with concerned tenants and our experiences. The importance of handing every tenant in a good way is a factor to consider achieving a good result.

Project with a combination changing the ventilation and radon extractors.

The action plan radon mitigation. The importance of telling the customer the plan and timeschedule. Example of installation of radon extractors in cellar and presentation of the measured results after installation.

Some examples of how the installation can be done with pictures.

General goals when installing is to aim for low noise ,easy to access for service but not too easy access for tenants.

Good mounting equipment to use is wall brackets, mounting plate, straps and silencer for the exhaust pipe.

Drilling in the ground slab and sealing:

The dimension of the drilled hole has to be big enough to give access to dig out material from under the slab. At least a "big bucket" of material. It is important to make some volume in the gravel under the slab on ground at each suction point in order for the fan to work properly. That is to ensure that the hole doesn't collapse and risk that material will be sucked into the pipes and do damage to the equipment.

Drilled hole dimension is often between 80-110 mm. A diminishing hose is used to fit to the piping system. The drilled holes can be sealed with various methods.

The longtime measuring presentation with the results before and after the mitigation project. To use as a receipt for the customer that he has got the result he paid for. And a good documentation has to be done also for proving that the dwelling is "radon secured".

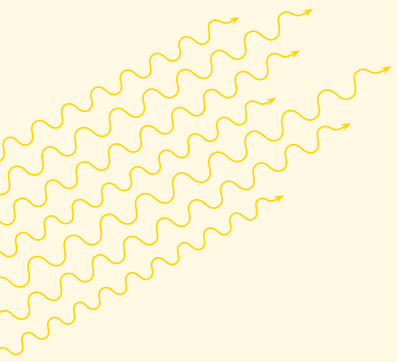

notes

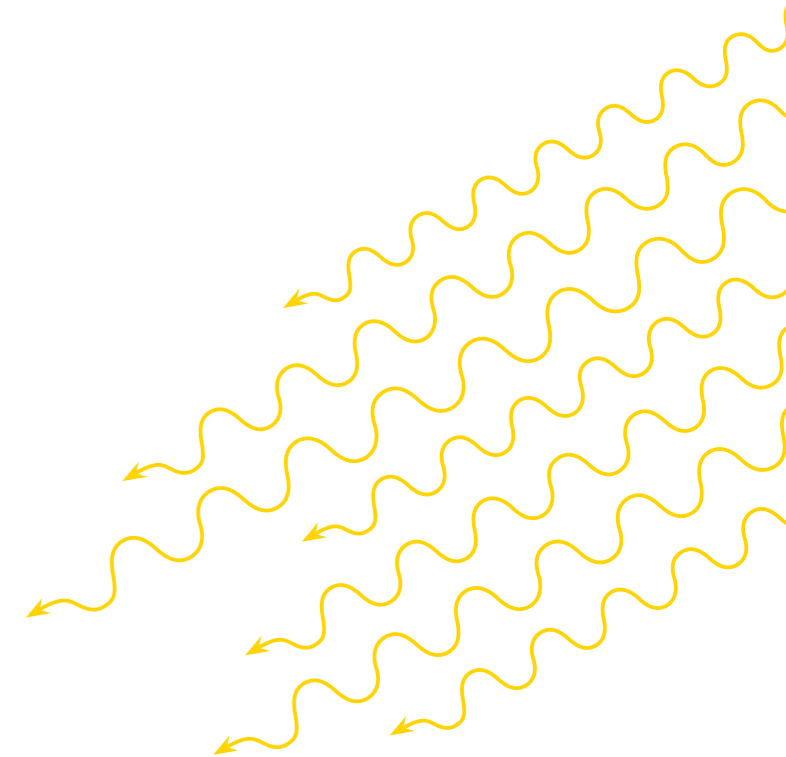

Lined writing area on page 62.

Lined writing area on page 63.

Lined writing area on page 64.

Lined writing area on page 65.

Lined writing area on page 70.

Lined writing area on page 71.

Herausgeber:

Sächsisches Staatsministerium für Umwelt und Landwirtschaft
Postfach 10 05 10, 01076 Dresden
Bürgertelefon:
Telefon: +49 351 564-6814
Telefax: +49 351 564-2059
E-Mail: info@smul.sachsen.de
www.smul.sachsen.de

Redaktion:

SMUL, Referat Kerntechnik und Strahlenschutz

Gestaltung und Satz:

Heimrich & Hannot GmbH

Fotos:

Alle Rechte liegen bei den Autoren, bzw. Referenten.

Druck:

Druckerei Wagner

Redaktionsschluss:

21. November 2013

Auflagenhöhe:

120 Exemplare

Papier:

Gedruckt auf 100 % Recycling-Papier

Verteilerhinweis:

Diese Informationsschrift wird von der Sächsischen Staatsregierung im Rahmen ihrer verfassungsmäßigen Verpflichtung zur Information der Öffentlichkeit herausgegeben. Sie darf weder von Parteien noch von deren Kandidaten oder Helfern im Zeitraum von sechs Monaten vor einer Wahl zum Zwecke der Wahlwerbung verwendet werden. Dies gilt für alle Wahlen.

Missbräuchlich ist insbesondere die Verteilung auf Wahlveranstaltungen, an Informationsständen der Parteien sowie das Einlegen, Aufdrucken oder Aufkleben parteipolitischer Informationen oder Werbemittel. Untersagt ist auch die Weitergabe an Dritte zur Verwendung bei der Wahlwerbung.

Auch ohne zeitlichen Bezug zu einer bevorstehenden Wahl darf die vorliegende Druckschrift nicht so verwendet werden, dass dies als Parteinahme des Herausgebers zu Gunsten einzelner politischer Gruppen verstanden werden könnte.

Diese Beschränkungen gelten unabhängig vom Vertriebsweg, also unabhängig davon, auf welchem Wege und in welcher Anzahl diese Informationsschrift dem Empfänger zugegangen ist. Erlaubt ist jedoch den Parteien, diese Informationsschrift zur Unterrichtung ihrer Mitglieder zu verwenden.

Copyright

Diese Veröffentlichung ist urheberrechtlich geschützt. Alle Rechte, auch die des Nachdruckes von Auszügen und der fotomechanischen Wiedergabe, sind dem Herausgeber vorbehalten.